

# ARITHMETIC

## SETS

1.

For an overlapping sets problem it is best to use a double set matrix to organize the information and solve. Fill in the information in the order in which it is given.

*Of the films Empty Set Studios released last year, 60% were comedies and the rest were horror films.*

	Comedies	Horror Films	Total
Profitable			
Unprofitable			
Total	<b>0.6x</b>	<b>0.4x</b>	<b>x</b>

*75% of the comedies were profitable, but 75% of the horror moves were unprofitable.*

	Comedies	Horror Films	Total
Profitable	<b>0.75(0.6x)</b>		
Unprofitable		<b>0.75(0.4x)</b>	
Total	0.6x	0.4x	x

*If the studio made a total of 40 films...*

	Comedies	Horror Films	Total
Profitable	$0.75(24) = 18$		
Unprofitable		$0.75(16) = 12$	
Total	$0.6(40) = 24$	$0.4(40) = 16$	<b>x = 40</b>

Since each row and each column must sum up to the Total value, we can fill in the remaining boxes.

	Comedies	Horror Films	Total
Profitable	18	<b>4</b>	<b>22</b>
Unprofitable	<b>6</b>	12	<b>18</b>
Total	24	16	40

The problem seeks the total number of profitable films, which is 22.

The correct answer is E.

2.

For an overlapping sets problem we can use a double-set matrix to organize our information and solve. Because the values are in percents, we can assign a value of 100 for the total number of interns at the hospital. Then, carefully fill in the matrix based on the information provided in the problem. The matrix below details this information. Notice that the variable  $x$  is used to detail the number of interns who receive 6 or more hours of sleep, 70% of whom reported no feelings of tiredness.

	Tired	Not Tired	TOTAL
6 or more hours	$.3x$	$.7x$	$x$
Fewer than 6 hours	75		80
TOTAL			100

In a double-set matrix, the sum of the first two rows equals the third and the sum of the first two columns equals the third. Thus, the boldfaced entries below were derived using the above matrix.

	Tired	Not Tired	TOTAL
6 or more hours	<b>6</b>	<b>14</b>	<b>20</b>
Fewer than 6 hours	75	<b>5</b>	80
TOTAL	<b>81</b>	<b>19</b>	100

We were asked to find the percentage of interns who reported no feelings of tiredness, or 19% of the interns.

The correct answer is C.

3.

This is an overlapping sets problem concerning two groups (students in either band or orchestra) and the overlap between them (students in both band and orchestra).

If the problem gave information about the students only in terms of percents, then a smart number to use for the total number of students would be 100. However, this problem gives an actual number of students (“there are 119 students in the band”) in addition to the percentages given. Therefore, we cannot assume that the total number of students is 100.

Instead, first do the problem in terms of percents. There are three types of students: those in band, those in orchestra, and those in both. 80% of the students are in only one group. Thus, 20% of the students are in both groups. 50% of the students are in the band only. We can use those two figures to determine the percentage of students left over:  $100\% - 20\% - 50\% = 30\%$  of the students are in the orchestra only.

Great - so 30% of the students are in the orchestra only. But although 30 is an answer choice, watch out! The question doesn't ask for the percentage of students in the orchestra only, it asks for the number of students in the orchestra only. We must figure out how many students are in Music High School altogether.

The question tells us that 119 students are in the band. We know that 70% of the students are in the band: 50% in band only, plus 20% in both band and orchestra. If we let  $x$  be the total number of students, then 119 students are 70% of  $x$ , or  $119 = .7x$ . Therefore,  $x = 119 / .7 = 170$  students total.

The number of students in the orchestra only is 30% of 170, or  $.3 \times 170 = 51$ .

The correct answer is B.

4.

For an overlapping set problem we can use a double-set matrix to organize our information and solve. Let's call  $P$  the number of people at the convention. The **boldface** entries in the matrix below were given in the question. For example, we are told that one sixth of the attendees are female students, so we put a value of  $P/6$  in the female students cell.

	FEMALE	NOT FEMALE	TOTALS
STUDENTS	<b><math>P/6</math></b>	$P/6$	<b><math>P/3</math></b>
NON STUDENTS	$P/2$	<b>150</b>	$2P/3$
TOTALS	<b><math>2P/3</math></b>	$P/3$	<b><math>P</math></b>

The non-boldfaced entries can be derived using simple equations that involve the numbers in one of the "total" cells. Let's look at the "Female" column as an example. Since we know the number of female students ( $P/6$ ) and we know the total number of females ( $2P/3$ ), we can set up an equation to find the value of female non-students:

$$P/6 + \text{Female Non Students} = 2P/3.$$

Solving this equation yields:  $\text{Female Non Students} = 2P/3 - P/6 = P/2$ .

By solving the equation derived from the "NOT FEMALE" column, we can determine a value for  $P$ .

$$\frac{P}{6} + 150 = \frac{P}{3} \longrightarrow P + 900 = 2P \longrightarrow P = 900$$

The correct answer is E.

5.

For an overlapping set problem we can use a double-set matrix to organize our information and solve. Because the values here are percents, we can assign a value of 100 to the total number of lights at Hotel California. The information given to us in the question is shown in the matrix in boldface. An  $x$  was assigned to the lights that were "Supposed To Be Off" since the values given in the problem reference that amount. The other values were filled in using the fact that in a double-set matrix the sum of the first two rows equals the third and the sum of the first two columns equals the third.

	Supposed To Be On	Supposed To Be Off	TOTAL
Actually on		<b><math>0.4x</math></b>	<b>80</b>
Actually off	<b><math>0.1(100 - x)</math></b>	$0.6x$	20
TOTAL	$100 - x$	<b><math>x</math></b>	<b>100</b>

Using the relationships inherent in the matrix, we see that:

$$0.1(100 - x) + 0.6x = 20$$

$$10 - 0.1x + 0.6x = 20$$

$$0.5x = 10 \text{ so } x = 20$$

We can now fill in the matrix with values:

	Supposed To Be On	Supposed To Be Off	TOTAL
Actually on	72	8	80
Actually off	8	12	20
TOTAL	80	20	100

Of the 80 lights that are actually on, 8, or 10% percent, are supposed to be off.

The correct answer is D.

6.

This question involves overlapping sets so we can employ a double-set matrix to help us. The two sets are speckled/rainbow and male/female. We can fill in 645 for the total number of total speckled trout based on the first sentence. Also, we can assign a variable,  $x$ , for female speckled trout and the expression  $2x + 45$  for male speckled trout, also based on the first sentence.

	Male	Female	Total
Speckled	$2x + 45$	$x$	645
Rainbow			
Total			

We can solve for  $x$  with the following equation:  $3x + 45 = 645$ . Therefore,  $x = 200$ .

	Male	Female	Total
Speckled	445	200	645
Rainbow			
Total			

If the ratio of female speckled trout to male rainbow trout is 4:3, then there must be 150 male rainbow trout. We can easily solve for this with the below proportion where  $y$  represents male rainbow trout:

$$\frac{4}{3} = \frac{200}{y}$$

Therefore,  $y = 150$ . Also, if the ratio of male rainbow trout to all trout is 3:20, then there must be 1000 total trout using the below proportion, where  $z$  represents all trout:

$$\frac{3}{20} = \frac{150}{z}$$

	Male	Female	Total
Speckled	445	200	645
Rainbow	150		
Total			1000

Now we can just fill in the empty boxes to get the number of female rainbow trout.

	Male	Female	Total
Speckled	445	200	645
Rainbow	150	205	355
Total			1000

The correct answer is D.

7.

Begin by constructing a double-set matrix and filling in the information given in the problem. Assume there are 100 major airline companies in total since this is an easy number to work with when dealing with percent problems.

	Wireless	No Wireless	TOTAL
Snacks	? MAX ?		70
NO Snacks			30
TOTAL	30	70	100

Notice that we are trying to maximize the cell where *wireless* intersects with *snacks*. What is the maximum possible value we could put in this cell. Since the total of the snacks row is 70 and the total of the wireless column is 30, it is clear that 30 is the limiting number. The maximum value we can put in the wireless-snacks cell is therefore 30. We can put 30 in this cell and then complete the rest of the matrix to ensure that all the sums will work correctly.

	Wireless	No Wireless	TOTAL
Snacks	<b>30</b>	40	70
NO Snacks	0	30	30
TOTAL	30	70	100

The correct answer is B.

8.

For an overlapping set problem we can use a double-set matrix to organize our information and solve. Because the given values are all percentages, we can assign a value of 100 to the total number of people in country Z. The matrix is filled out below based on the information provided in the question.

The first sentence tells us that 10% of all of the people do have their job of choice but do not have a diploma, so we can enter a 10 into the relevant box, below. The second sentence tells us that 25% of those who do not have their job of choice have a diploma. We don't know how many people do not have their job of choice, so we enter a variable (in this case,  $x$ ) into that box. Now we can enter 25% of those people, or  $0.25x$ , into the relevant box, below. Finally, we're told that 40% of all of the people have their job of choice.

	University Diploma	NO University Diploma	TOTAL
Job of Choice		10	40
NOT Job of Choice	$0.25x$		$x$
TOTAL			100

In a double-set matrix, the sum of the first two rows equals the third and the sum of the first two columns equals the third. Thus, the boldfaced entries below were derived using relationships (for example:  $40 + x = 100$ , therefore  $x = 60$ .  $0.25 \times 60 = 15$ . And so on.).

	University Diploma	NO University Diploma	TOTAL
Job of Choice	<b>30</b>	10	40
NOT Job of Choice	<b>15</b>	<b>45</b>	<b>60</b>
TOTAL	<b>45</b>	<b>55</b>	100

We were asked to find the percent of the people who have a university diploma, or 45%.

The correct answer is B.

9.

This is a problem that involves two overlapping sets so it can be solved using a double-set matrix. The problem tells us that there are 800 total students of whom 70% or 560 are male. This means that 240 are female and we can begin filling in the matrix as follows:

	Male	Female	TOTAL
Sport			
No Sport			<i>maximize</i>
TOTAL	560	240	800

The question asks us to MAXIMIZE the total number of students who do NOT participate in a sport. In order to maximize this total, we will need to maximize the number of females who do NOT participate in and the number of males who do NOT participate in a sport.

The problem states that at least 10% of the female students, or 24 female students, participate in a sport. This leaves 216 female students who may or may not participate in a sport. Since we want to maximize the number of female students who do NOT participate in a sport, we will assume that all 216 of these remaining female students do not participate in a sport.

The problem states that fewer than 30% of the male students do NOT participate in a sport. Thus, fewer than 168 male students (30% of 560) do NOT participate in a sport. Thus anywhere from 0 to 167 male students do NOT participate in a sport. Since we want to maximize the number of male students who do NOT participate in a sport, we will assume that 167 male students do NOT participate in a sport. This leaves 393 male students who do participate in a sport.

Thus, our matrix can now be completed as follows:

	Male	Female	TOTAL
Sport	393	24	417
No Sport	167	216	<b>383</b>
TOTAL	560	240	800

Therefore, the maximum possible number of students in School T who do not participate in a sport is 383.

The correct answer is B.

### 10.

This is an overlapping sets problem, which can be solved most efficiently by using a double set matrix. Our first step in using the double set matrix is to fill in the information given in the question. Because there are no real values given in the question, the problem can be solved more easily using 'smart numbers'; in this case, we can assume the total number of rooms to be 100 since we are dealing with percentages. With this assumption, we can fill the following information into our matrix:

There are 100 rooms total at the Stagecoach Inn.

Of those 100 rooms, 75 have a queen-sized bed, while 25 have a king-sized bed.

Of the non-smoking rooms (let's call this unknown  $n$ ), 60% or  $.6n$  have queen-sized beds.

10 rooms are non-smoking with king-sized beds.

Let's fill this information into the double set matrix, including the variable  $n$  for the value we need to solve the problem:

	SMOKING	NON-SMOKING	TOTALS
KING BED		10	25
QUEEN BED		$.6n$	75
TOTALS		$n$	100

In a double-set matrix, the first two rows sum to the third, and the first two columns sum to the third. We can therefore solve for  $n$  using basic algebra:

$$10 + .6n = n$$

$$10 = .4n$$

$$n = 25$$

We could solve for the remaining empty fields, but this is unnecessary work. Observe that the total number of smoking rooms equals  $100 - n = 100 - 25 = 75$ . Recall that we are working with smart numbers that represent percentages, so 75% of the rooms at the Stagecoach Inn permit smoking.

The correct answer is E.

### 11.

For an overlapping set problem we can use a double-set matrix to organize our information and solve. The boldfaced values were given in the question. The non-boldfaced values were derived using the fact that in a double-set matrix, the sum of the first two rows equals the third and the sum of the first two columns equals the third. The variable  $p$  was used for the total number of pink roses, so that the total number of pink and red roses could be solved using the additional information given in the question.

	Red	Pink	White	TOTAL
Long-stemmed			<b>0</b>	80
Short-stemmed	5	<b>15</b>	<b>20</b>	<b>40</b>
TOTAL	$100 - p$	$p$	20	<b>120</b>

The question states that the percentage of red roses that are short-stemmed is equal to the percentage of pink roses that are short stemmed, so we can set up the following proportion:

$$\frac{5}{100 - p} = \frac{15}{p}$$

$$5p = 1500 - 15p$$

$$p = 75$$

This means that there are a total of 75 pink roses and 25 red roses. Now we can fill out the rest of the double-set matrix:

	Red	Pink	White	TOTAL
Long-stemmed	20	60	<b>0</b>	80
Short-stemmed	5	<b>15</b>	<b>20</b>	<b>40</b>
TOTAL	25	75	20	<b>120</b>

Now we can answer the question. 20 of the 80 long-stemmed roses are red, or  $20/80 = 25\%$ .

The correct answer is B.

## 12.

You can solve this problem with a matrix. Since the total number of diners is unknown and not important in solving the problem, work with a hypothetical total of 100 couples. Since you are dealing with percentages, 100 will make the math easier.

Set up the matrix as shown below:

	Dessert	NO dessert	TOTAL
Coffee			
NO coffee			
TOTAL			<b>100</b>

Since you know that 60% of the couples order BOTH dessert and coffee, you can enter that number into the matrix in the upper left cell.

	Dessert	NO dessert	TOTAL
Coffee	<b>60</b>		
NO coffee			
TOTAL			100

The next useful piece of information is that 20% of the couples who order dessert don't order coffee. **But be careful!** The problem does not say that 20% of the *total* diners order dessert and don't order coffee, so you CANNOT fill in 40 under "dessert, no coffee" (first column, middle row). Instead, you are told that 20% **of the couples who order dessert** don't order coffee.

Let  $x$  = total number of couples who order dessert. Therefore you can fill in  $.2x$  for the number of couples who order dessert but no coffee.

	Dessert	NO dessert	TOTAL
Coffee	60		
NO coffee	$.2x$		
TOTAL	$x$		100

Set up an equation to represent the couples that order dessert and solve:

$$60 + .2x = x$$

$$60 = .8x$$

$$x = 75$$

75% of all couples order dessert. Therefore, there is only a 25% chance that the next couple the maitre 'd seats will *not* order dessert. The correct answer is B.

13.

This problem can be solved using a set of three equations with three unknowns. We'll use the following definitions:

Let  $F$  = the number of Fuji trees

Let  $G$  = the number of Gala trees

Let  $C$  = the number of cross pollinated trees

10% of his trees cross pollinated

$$C = 0.1(F + G + C)$$

$$10C = F + G + C$$

$$9C = F + G$$

The pure Fujis plus the cross pollinated ones total 187

$$(4) F + C = 187$$

3/4 of his trees are pure Fuji

$$(5) F = (3/4)(F + G + C)$$

$$(6) 4F = 3F + 3G + 3C$$

$$(7) F = 3G + 3C$$

Substituting the value of  $F$  from equation (7) into equation (3) gives us:

$$(8) 9C = (3G + 3C) + G$$

$$(9) 6C = 4G$$

$$(10) 12C = 8G$$

Substituting the value of  $F$  from equation (7) into equation (4) gives us:

$$(11) (3G + 3C) + C = 187$$

$$(12) 3G + 4C = 187$$

$$(13) 9G + 12C = 561$$

Substituting equation (10) into (13) gives:

$$(14) 9G + 8G = 561$$

$$(15) 17G = 561$$

$$(16) G = 33$$

So the farmer has 33 trees that are pure Gala. The correct answer is B.

14.

For an overlapping set problem with three subsets, we can use a Venn diagram to solve.

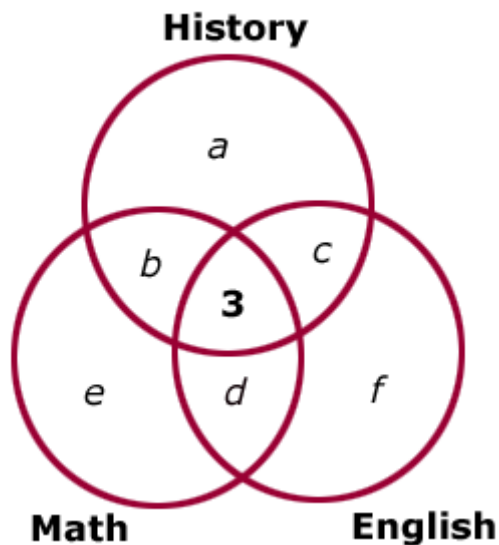

Each circle represents the number of students enrolled in the History, English and Math classes, respectively. Notice that each circle is subdivided into different groups of students. Groups  $a$ ,  $e$ , and  $f$  are comprised of students taking only 1 class. Groups  $b$ ,  $c$ , and  $d$  are comprised of students taking 2 classes. In addition, the diagram shows us that 3 students are taking all 3 classes. We can use the diagram and the information in the question to write several equations:

History students:  $a + b + c + 3 = 25$   
 Math students:  $e + b + d + 3 = 25$   
 English students:  $f + c + d + 3 = 34$   
 TOTAL students:  $a + e + f + b + c + d + 3 = 68$

The question asks for the total number of students taking exactly 2 classes. This can be represented as  $b + c + d$ .

If we sum the first 3 equations (History, Math and English) we get:

$$a + e + f + 2b + 2c + 2d + 9 = 84.$$

Taking this equation and subtracting the 4<sup>th</sup> equation (Total students) yields the following:

$$\begin{array}{r} a + e + f + 2b + 2c + 2d + 9 = 84 \\ -[a + e + f + b + c + d + 3 = 68] \\ \hline b + c + d = 10 \end{array}$$

The correct answer is B.

**15.**

This problem involves 3 overlapping sets. To visualize a 3 set problem, it is best to draw a Venn Diagram.

We can begin filling in our Venn Diagram utilizing the following 2 facts: (1) The number of bags that contain only raisins is 10 times the number of bags that contain only peanuts. (2) The number of bags that contain only almonds is 20 times the number of bags that contain only raisins and peanuts.

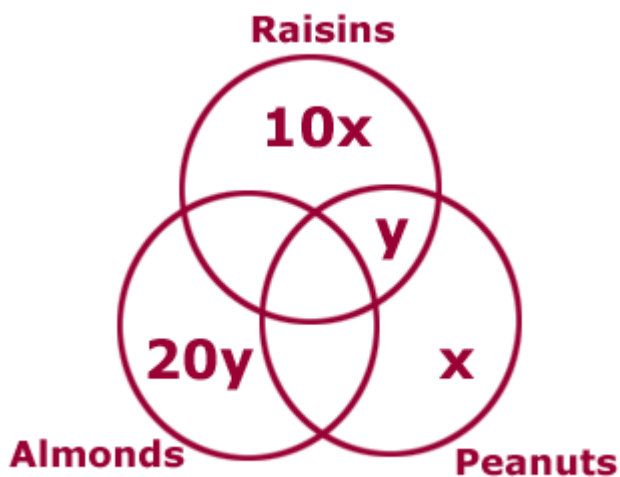

Next, we are told that the number of bags that contain only peanuts (which we have represented as  $x$ ) is one-fifth the number of bags that contain only almonds (which we have represented as  $20y$ ).

This yields the following equation:  $x = (1/5)20y$  which simplifies to  $x = 4y$ . We can use this information to revise our Venn Diagram by substituting any  $x$  in our original diagram with  $4y$  as follows:

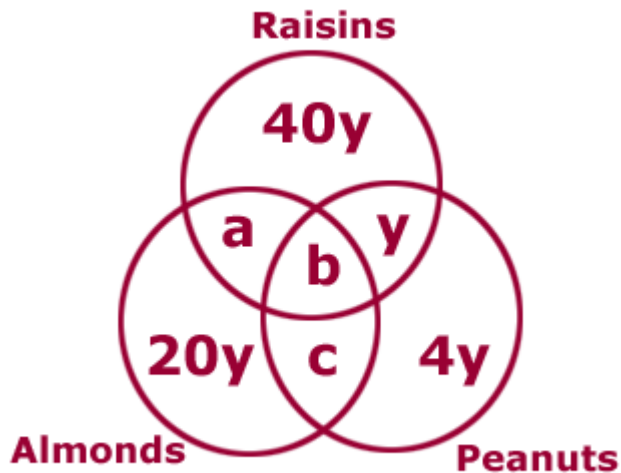

Notice that, in addition to performing this substitution, we have also filled in the remaining open spaces in the diagram with the variable  $a$ ,  $b$ , and  $c$ .

Now we can use the numbers given in the problem to write 2 equations. First, the sum of all the expressions in the diagram equals 435 since we are told that there are 435 bags in total. Second, the sum of all the expressions in the almonds circle equals 210 since we are told that 210 bags contain almonds.

$$435 = 20y + a + b + c + 40y + y + 4y$$
$$210 = 20y + a + b + c$$

Subtracting the second equation from the first equation, yields the following:

$$225 = 40y + y + 4y$$
$$225 = 45y$$
$$5 = y$$

Given that  $y = 5$ , we can determine the number of bags that contain only one kind of item as follows:

$$\text{The number of bags that contain only raisins} = 40y = 200$$
$$\text{The number of bags that contain only almonds} = 20y = 100$$
$$\text{The number of bags that contain only peanuts} = 4y = 20$$

Thus there are 320 bags that contain only one kind of item. The correct answer is D.

16.

This is an overlapping sets problem. This question can be effectively solved with a double-set matrix composed of two overlapping sets: [Spanish/Not Spanish] and [French/Not French]. When constructing a double-set matrix, remember that the two categories adjacent to each other must be mutually exclusive, i.e. [French/not French] are mutually exclusive, but [French/not Spanish] are not mutually exclusive. Following these rules, let's construct and fill in a double-set matrix for each statement. To simplify our work with percentages, we will also pick 100 for the total number of students at Jefferson High School.

INSUFFICIENT: While we know the percentage of students who take French and, from that information, the percentage of students who do not take French, we do not know anything about the students taking Spanish. Therefore we don't know the percentage of students who study French but not Spanish, i.e. the number in the target cell denoted with  $x$ .

	FRENCH	NOT FRENCH	TOTALS
SPANISH			
NOT SPANISH	$x$		
TOTALS	30	70	100

(2) INSUFFICIENT: While we know the percentage of students who do not take Spanish and, from that information, the percentage of students who do take Spanish, we do not know anything about the students taking French. Therefore we don't know the percentage of students who study French but not Spanish, i.e. the number in the target cell denoted with  $x$ .

	FRENCH	NOT FRENCH	TOTALS
SPANISH			60
NOT SPANISH	$x$		40
TOTALS			100

AND (2) INSUFFICIENT: Even after we combine the two statements, we do not have sufficient information to find the percentage of students who study French but not Spanish, i.e. to fill in the target cell denoted with  $x$ .

	FRENCH	NOT FRENCH	TOTALS
SPANISH			60
NOT SPANISH	$x$		40
TOTALS	30	70	100

The correct answer is E.

17.

For this overlapping set problem, we want to set up a two-set table to test our possibilities. Our first set is vegetarians vs. non-vegetarians; our second set is students vs. non-students.

	VEGETARIAN	NON-VEGETARIAN	TOTAL
STUDENT			
NON-STUDENT		15	
TOTAL	$x$	$x$	?

We are told that each non-vegetarian non-student ate exactly one of the 15 hamburgers, and that nobody else ate any of the 15 hamburgers. This means that there were exactly 15 people in the non-vegetarian non-student category. We are also told that the total number of vegetarians was equal to the total number of non-vegetarians; we represent this by putting the same variable in both boxes of the chart.

The question is asking us how many people attended the party; in other words, we are being asked for the number that belongs in the bottom-right box, where we have placed a question mark.

The second statement is easier than the first statement, so we'll start with statement (2).

(2) INSUFFICIENT: This statement gives us information only about the cell labeled "vegetarian non-student"; further it only tells us the number of these guests as a *percentage* of the total guests. The 30% figure does not allow us to calculate the actual number of any of the categories.

SUFFICIENT: This statement provides two pieces of information. First, the vegetarians attended at the rate, or in the ratio, of 2:3 students to non-

students. We're also told that this 2:3 rate is half the rate for non-vegetarians. In order to double a rate, we double the first number; the rate for non-vegetarians is 4:3. We can represent the actual numbers of non-vegetarians as  $4a$  and  $3a$  and add this to the chart below. Since we know that there were 15 non-vegetarian non-students, we know the missing common multiple,  $a$ , is  $15/3 = 5$ . Therefore, there were  $(4)(5) = 20$  non-vegetarian students and  $20 + 15 = 35$  total non-vegetarians (see the chart below). Since the same number of vegetarians and non-vegetarians attended the party, there were also 35 vegetarians, for a total of 70 guests.

	VEGETARIAN	NON-VEGETARIAN	TOTAL
STUDENT		$4a$ or 20	
NON-STUDENT		$3a$ or 15	
TOTAL	$x$ or 35	$x$ or 35	? or 70

The correct answer is A.

18.

For an overlapping set question, we can use a double-set matrix to organize the information and solve. The two sets in this question are the practical test (pass/fail) and the written test (pass/fail).

From the question we can fill in the matrix as follows. In a double-set matrix, the sum of the first two rows equals the third and the sum of the first two columns equals the third. The bolded value was derived from the other given values. The question asks us to find the value of  $.7x$ .

	PRACTICAL - PASS	PRACTICAL - FAIL	TOTALS
WRITTEN - PASS	<b><math>.7x</math></b>	$.3x$	$x$
WRITTEN - FAIL		0	
TOTALS		$.3x$	

(1) INSUFFICIENT: If we add the total number of students to the information from the question, we do not have enough to solve for  $.7x$ .

	PRACTICAL - PASS	PRACTICAL - FAIL	TOTALS
WRITTEN - PASS	$.7x$	$.3x$	$x$
WRITTEN - FAIL		0	
TOTALS		$.3x$	188

(2) INSUFFICIENT: If we add the fact that 20% of the *sixteen year-olds who passed the practical test* failed the written test to the original matrix from the question, we can come up with the relationship  $.7x = .8y$ . However, that is not enough to solve for  $.7x$ .

	PRACTICAL - PASS	PRACTICAL - FAIL	TOTALS
WRITTEN - PASS	$.7x = .8y$	$.3x$	$x$
WRITTEN - FAIL	$.2y$	0	$.2y$
TOTALS	$y$	$.3x$	

(1) AND (2) SUFFICIENT: If we combine the two statements we get a matrix that can be used to form two relationships between  $x$  and  $y$ :

	PRACTICAL - PASS	PRACTICAL - FAIL	TOTALS
WRITTEN - PASS	$.7x = .8y$	$.3x$	$x$
WRITTEN - FAIL	$.2y$	0	$.2y$
TOTALS	$y$	$.3x$	188

$$.7x = .8y$$

$$y + .3x = 188$$

This would allow us to solve for  $x$  and in turn find the value of  $.7x$ , the number of sixteen year-olds who received a driver license.

The correct answer is C.

19.

For an overlapping set problem we can use a double-set matrix to organize our information and solve. We are told in the question stem that 180 guests have a house in the Hamptons and a house in Palm Beach. We can insert this into our matrix as follows:

	House in Hamptons	No House in Hamptons	TOTALS
House in Palm Beach	180		
No House in Palm Beach			
TOTALS			$T$

The question is asking us for the ratio of the darkly shaded box to the lightly shaded box.

INSUFFICIENT: Since one-half of all the guests had a house in Palm Beach, we can fill in the matrix as follows:

	House in Hamptons	No House in Hamptons	TOTALS
House in Palm Beach	180	$(1/2)T - 180$	$(1/2)T$
No House in Palm Beach			
TOTALS			$T$

We cannot find the ratio of the dark box to the light box from this information alone.

(2) INSUFFICIENT: Statement 2 tells us that two-thirds of all the guests had a house in the Hamptons. We can insert this into our matrix as follows:

	House in Hamptons	No House in Hamptons	TOTALS
House in Palm Beach	180		
No House in Palm Beach	$(2/3)T - 180$		
TOTALS	$(2/3)T$		$T$

We cannot find the ratio of the dark box to the light box from this information alone.

(1) AND (2) INSUFFICIENT: we can fill in our matrix as follows.

	House in Hamptons	No House in Hamptons	TOTALS
House in Palm Beach	180	$(1/2)T - 180$	$(1/2)T$
No House in Palm Beach	$(2/3)T - 180$	<b><math>180 - (1/6)T</math></b>	<b><math>(1/2)T</math></b>
TOTALS	$(2/3)T$	<b><math>(1/3)T</math></b>	$T$

The ratio of the number of people who had a house in Palm Beach but not in the Hamptons to the number of people who had a house in the Hamptons but not in Palm Beach (i.e. dark to light) will be:

$$\frac{(1/2)T - 180}{(2/3)T - 180}$$

$$\frac{(1/2)T - 180}{(2/3)T - 180}$$

This ratio doesn't have a constant value; it depends on the value of  $T$ . We can try to solve for  $T$  by filling out the rest of the values in the matrix (see the **bold** entries above); however, any equation that we would build using these values reduces to a redundant statement of  $T = T$ . This means there isn't enough unique information to solve for  $T$ .

The correct answer is E.

20.

Since there are two different classes into which we can divide the participants, we can solve this using a double-set matrix. The two classes into which we'll divide the participants are Boys/Girls along the top (as column labels), and Chocolate/Strawberry down the left (as row labels).

The problem gives us the following data to fill in the initial double-set matrix. We want to know if we can determine the maximum value of  $a$ , which represents the number of girls who ate chocolate ice cream.

	BOYS	GIRLS	TOTALS
CHOCOLATE	8	$a$	
STRAWBERRY		9	
TOTALS			

(1) SUFFICIENT: Statement (1) tells us that exactly 30 children came to the party, so we'll fill in 30 for the grand total. Remember that we're trying to maximize  $a$ .

	BOYS	GIRLS	TOTALS
CHOCOLATE	8	$a$	$b$
STRAWBERRY	$c$	9	$d$
TOTALS			30

In order to maximize  $a$ , we must maximize  $b$ , the total number of chocolate eaters.

Since

$b + d = 30$ , implying  $b = 30 - d$ , we must minimize  $d$  to maximize  $b$ . To minimize  $d$  we must minimize  $c$ . The minimum value for  $c$  is 0, since the question doesn't say that there were necessarily boys who had strawberry ice cream.

Now that we have an actual value for  $c$ , we can calculate forward to get the maximum possible value for  $a$ . If  $c = 0$ , since we know that  $c + 9 = d$ , then  $d = 9$ . Since  $b + d = 30$ , then  $b = 21$ . Given that  $8 + a = b$  and  $b = 21$ , then  $a = 13$ , the maximum value we

were looking for. Therefore statement (1) is sufficient to find the maximum number of girls who ate chocolate.

(2) INSUFFICIENT: Knowing only that fewer than half of the people ate strawberry ice cream doesn't allow us to fill in any of the boxes with any concrete numbers. Therefore statement (2) is insufficient.

The correct answer is A.

**21.**

Since we are dealing with overlapping sets and there are two independent criteria, the best way to solve this problem is with a double-set matrix.

The first statement in the question stem tells us that of the students who speak French (represented by the first column), four times as many speak German as don't. This information yields the following entries in the double-set matrix:

	FRENCH	NO FRENCH	TOTALS
GERMAN	$4x$		
NO GERMAN	$x$		
TOTALS			

The second statement in the question stem tells us that  $1/6$  of the of the students who don't speak German do speak French. This is fact represented in the double-set matrix as follows:

	FRENCH	NO FRENCH	TOTALS
GERMAN	$4x$		
NO GERMAN	$x = y/6$		$y$
TOTALS			

Now since  $x = y/6$ , we can get rid of the new variable  $y$  and keep all the expressions in terms of  $x$ .

	FRENCH	NO FRENCH	TOTALS
GERMAN	$4x$		
NO GERMAN	$x$		$6x$
TOTALS			

Now we can fill in a few more boxes using the addition rules for the double-set matrix.

	FRENCH	NO FRENCH	TOTALS
GERMAN	$4x$		
NO GERMAN	$x$	$5x$	$6x$
TOTALS	$5x$		

The main question to be answered is what fraction of the students speak German, a fraction represented by  $A/B$  in the final double-set matrix. So, if statements (1) and/or (2) allow us to calculate a numerical value for  $A/B$ , we will be able to answer the question.

	FRENCH	NO FRENCH	TOTALS
GERMAN	$4x$		$A$
NO GERMAN	$x$	$5x$	$6x$
TOTALS	$5x$		$B$

(1) INSUFFICIENT: Statement (1) tells us that 60 students speak French and German, so  $4x = 60$  and  $x = 15$ . We can now calculate any box labeled with an  $x$ , but this is still insufficient to calculate  $A$ ,  $B$ , or  $A/B$ .

(2) INSUFFICIENT: Statement (2) tells us that 75 students speak neither French nor German, so  $5x = 75$  and  $x = 15$ . Just as with Statement (1), we can now calculate any box labeled with an  $x$ , but this is still insufficient to calculate  $A$ ,  $B$ , or  $A/B$ .

(1) AND (2) INSUFFICIENT: Since both statements give us the same information (namely, that  $x = 15$ ), putting the two statements together does not tell us anything new. Therefore (1) and (2) together are insufficient.

The correct answer is E.

## 22.

In an overlapping set problem, we can use a double set matrix to organize the information and solve.

From information given in the question, we can fill in the matrix as follows:

	GREY	WHITE	TOTALS
BLUE		> 3	
BROWN			
TOTALS			55

The question is asking us if the total number of blue-eyed wolves (fourth column, second row) is greater than the total number of brown-eyed wolves (fourth column, third row).

(1) INSUFFICIENT. This statement allows us to fill in the matrix as below. We have no information about the total number of brown-eyed wolves.

	GREY	WHITE	TOTALS
BLUE	$4x$	$3x$	$7x$
BROWN			
TOTALS			55

(2) INSUFFICIENT. This statement allows us to fill in the matrix as below. We have no information about the total number of blue-eyed wolves.

	GREY	WHITE	TOTALS
BLUE			
BROWN	$1y$	$2y$	$3y$
TOTALS			55

TOGETHER, statements (1) + (2) are SUFFICIENT. Combining both statements, we can fill in the matrix as follows:

	GREY	WHITE	TOTALS
BLUE	$4x$	$3x$	$7x$
BROWN	$1y$	$2y$	$3y$
TOTALS	$4x + y$	$3x + 2y$	55

Using the additive relationships in the matrix, we can derive the equation  $7x + 3y = 55$  (notice that adding the grey and white totals yields the same equation as adding the blue and brown totals).

The original question can be rephrased as "Is  $7x > 3y$ ?"

On the surface, there *seems* to NOT be enough information to solve this question. However, we must consider some of the restrictions that are placed on the values of  $x$  and  $y$ :

(1)  **$x$  and  $y$  must be integers** (we are talking about numbers of wolves here and looking at the table,  $y$ ,  $3x$  and  $4x$  must be integers so  $x$  and  $y$  must be integers)

(2)  **$x$  must be greater than 1** (the problem says there are more than 3 blue-eyed wolves with white coats so  $3x$  must be greater than 3 or  $x > 1$ )

Since  $x$  and  $y$  must be integers, there are only a few  $x,y$  values that satisfy the equation  $7x + 3y = 55$ . By trying all integer values for  $x$  from 1 to 7, we can see that the only possible  $x,y$  pairs are:

$x$	$y$	$7x$	$3y$
1	16	7	48
<b>4</b>	<b>9</b>	<b>28</b>	<b>27</b>
<b>7</b>	<b>2</b>	<b>49</b>	<b>6</b>

Since  $x$  cannot be 1, the only two pairs yield  $7x$  values that are greater than the corresponding  $3y$  values ( $28 > 27$  and  $49 > 6$ ).

The correct answer is C.

23.

We can divide the current fourth graders into 4 categories:

The percentage that dressed in costume this year **ONLY**.

(2) The percentage that dressed in costume last year **ONLY**.

(3) The percentage that did **NOT** dress in costume either this year or last year.

(4) The percentage that dressed in costume **BOTH** years.

We need to determine the last category (category 4) in order to answer the question.

INSUFFICIENT: Let's assume there are 100 current fourth graders (this simply helps to make this percentage question more concrete). 60 of them dressed in costume this year, while 40 did not. However, we don't know how many of these 60 dressed in costume last year, so we can't divide this 60 up into categories 1 and 2.

INSUFFICIENT: This provides little relevant information on its own because we don't know how many of the students didn't dress up in costumes this year and the statement references that value.

(1) AND (2) INSUFFICIENT: From statement 1 we know that 60 dressed up in costumes this year, but 40 did not. Statement 2 tells us that 80% of these 40, or 32, didn't dress up in costumes this year either. This provides us with a value for category 3, from which we can derive a value for category 2 (8).

However, we still don't know how many of the 60 costume bearers from this year wore costumes last year.

Since this is an overlapping set problem, we could also have used a double-set matrix to organize our information and solve. Even with both statements together, we can not find the value for the Costume Last Year / Costume This Year cell.

	Costume This Year	No Costume This Year	TOTALS
Costume Last Year		8	
No Costume Last Year		32	
TOTALS	60	40	100

The correct answer is E.

24.

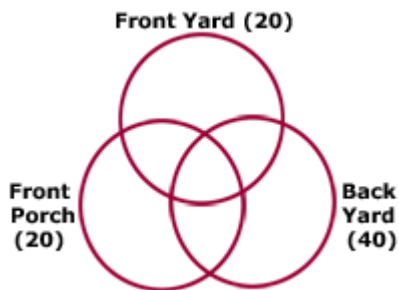

A Venn-Diagram is useful to visualize this problem.

Notice that the Venn diagram allows us to see the 7 different types of houses on Kermit lane. Each part of the diagram represents one type of house. For example, the center section of the diagram represents the houses that contain all three amenities (front yard, front porch, *and* back yard). Keep in mind that there may also be some houses on Kermit Lane that have none of the 3 amenities and so these houses would be outside the diagram.

**SUFFICIENT:** This tells us that no house on Kermit Lane is without a backyard. Essentially this means that there are 0 houses in the three sections of the diagram that are NOT contained in the Back Yard circle. It also means

that there are 0 houses outside of the diagram. Since we know that 40 houses on Kermit Lane contain a back yard, there must be exactly 40 houses on Kermit Lane.

INSUFFICIENT: This tells us that each house on Kermit Lane that has a front porch does not have a front yard. This means that there are 0 houses in the two sections of the diagram in which Front Yard overlaps with Front Porch. However, this does not give us information about the other sections of the diagram. Statement (2) ALONE is not sufficient.

The correct answer is A.

**25.**

This is a problem that involves three overlapping sets. A helpful way to visualize this is to draw a Venn diagram as follows:

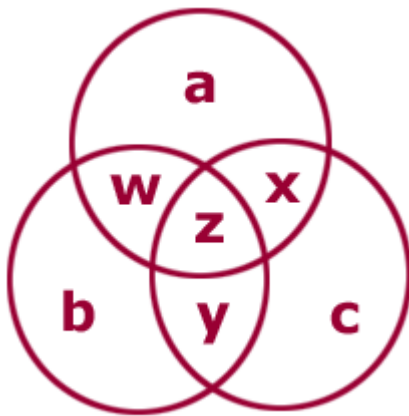

Each section of the diagram represents a different group of people. Section  $a$  represents those residents who are members of only club  $a$ . Section  $b$  represents those residents who are members of only club  $b$ . Section  $c$  represents those residents who are members of only club  $c$ . Section  $w$  represents those residents who are members of only clubs  $a$  and  $b$ . Section  $x$  represents those residents who are members of only clubs  $a$  and  $c$ . Section  $y$  represents those residents who are members of only clubs  $b$  and  $c$ . Section  $z$  represents those residents who are members of all three clubs.

The information given tells us that  $a + b + c = 40$ . One way of rephrasing the question is as follows: Is  $x > 0$ ? (Recall that  $x$  represents those residents who are member of fitness clubs A and C but not B).

Statement (1) tells us that  $z = 2$ . Alone, this does not tell us anything about  $x$ , which could, for example, be 0 or 10, among many other possibilities. This is clearly not sufficient to answer the question.

Statement (2) tells us that  $w + y = 8$ . This alone does not give us any information about  $x$ , which, again could be 0 or a number of other values.

In combining both statements, it is *tempting* to assert the following.

We know from the question stem that  $a + b + c = 40$ . We also know from statement one that  $z = 2$ . Finally, we know from statement two that  $w + y = 8$ . We can use these three pieces of information to write an equation for all 55 residents as follows:

$$\begin{aligned}a + b + c + w + x + y + z &= 55. \\(a + b + c) + x + (w + y) + (z) &= 55. \\40 + x + 8 + 2 &= 55 \\x &= 5\end{aligned}$$

This would suggest that there are 5 residents who are members of both fitness clubs A and C but not B.

*However, this assumes that all 55 residents belong to at least one fitness club. Yet, this fact is not stated in the problem. It is possible then, that 5 of the residents are not members of any fitness club. This would mean that 0 residents are members of fitness clubs A and C but not B.*

Without knowing how many residents are not members of any fitness club, we do not have sufficient information to answer this question.

The correct answer is E: Statements (1) and (2) TOGETHER are NOT sufficient.

26.

From 1, 16 students study both French and Japanese, so  $16/0.04=400$  students study French, combine "at least 100 students study Japanese", insufficient.

From 2, we can know that, 10% Japanese studying students=4% French studying students.

Apparently, more students at the school study French than study Japanese.

Answer is B

# Percentages

1.

Percentage problems involving unspecified amounts can usually be solved more easily by using the number 100. If Arthur's fortune was originally \$100, each of his children received \$20.

Let's see what happened to each \$20 investment in the first year:

Alice:  $\$20 + \$10 \text{ profit} = \$30$

Bob:  $\$20 + \$10 \text{ profit} = \$30$

Carol:  $\$20 + \$10 \text{ profit} = \$30$

Dave:  $\$20 - \$8 \text{ loss} = \$12$

Errol:  $\$20 - \$8 \text{ loss} = \$12$

We continue on with our new amounts in the second year:

Alice:  $\$30 + \$3 \text{ profit} = \$33$

Bob:  $\$30 + \$3 \text{ profit} = \$33$

Carol:  $\$30 - \$18 \text{ loss} = \$12$

Dave:  $\$12 + \$3 \text{ profit} = \$15$

Errol:  $\$12 - \$12 = 0$

At the end of two years,  $\$33 + \$33 + \$12 + \$15 = \$93$  of the original \$100 remains.

The correct answer is A.

2.

This is a weighted average problem; we cannot simply average the percentage of silver cars for the two batches because each batch has a different number of cars. The car dealership currently has 40 cars, 30% of which are silver. It receives 80 new cars, 60% of which are silver (the 40% figure given in the problem refers to cars which are *not* silver). Note that the first batch represents  $1/3$  of the total cars and the second batch represents  $2/3$  of the total cars. Put differently, in the new total group there is 1 *first-batch* car for every 2 *second-batch* cars.

We can calculate the weighted average, weighting each percent according to the ratio of the number of cars represented by that percent:

$$\text{Weighted average} = \frac{1(30\%) + 2(60\%)}{3} = \frac{150\%}{3} = 50\%$$

Alternatively, you can calculate the actual number of silver cars and divide by the total number of cars.  $40(0.3) + 80(0.6) = 12 + 48 = 60$ .  $60/120 = 50\%$ .

The correct answer is E.

3.

Notice that Paul's income is expressed as a percentage of Rex's and that the other two incomes are expressed as a percent of Paul's. Let's assign a value of \$100 to Rex's income. Paul's income is 40% less than Rex's income, so  $(0.6)(\$100) = \$60$ . Quentin's income is 20% less than Paul's income, so  $(0.8)(\$60) = \$48$ . Sam's income is 40% less than Paul's income, so  $(0.6)(\$60) = \$36$ . If Rex gives 60% of his income, or \$60, to Sam, and 40% of his income, or \$40, to Quentin, then: Sam would have  $\$36 + \$60 = \$96$  and Quentin would have  $\$48 + \$40 = \$88$ . Quentin's income would now be  $\$88/\$96 = 11/12$  that of Sam's.

The correct answer is A.

4.

Let's denote the formula for the money spent on computers as  $pq = b$ , where

$p$  = price of computers

$q$  = quantity of computers

$b$  = budget

We can solve a percent question that doesn't involve actual values by using smart numbers. Let's assign a smart number of 1000 to last year's computer budget ( $b$ ) and a smart number 100 to last year's computer price ( $p$ ). 1000 and 100 are easy numbers to take a percent of.

This year's budget will equal  $1000 \times 1.6 = 1600$

This year's computer price will equal  $100 \times 1.2 = 120$

Now we can calculate the number of computers purchased each year,  $q = b/p$

Number of computers purchased last year =  $1000/100 = 10$

Number of computers purchased this year =  $1600/120 = 13 \frac{1}{3}$  (while  $\frac{1}{3}$  of a computer doesn't make sense it won't affect the calculation)

	$p$	$q$	$b$
This Year	100	10	1000
Last Year	120	$\frac{13}{3}$	1600

The question is asking for the percent increase in quantity from last year to this year =  $\frac{\text{new} - \text{old}}{\text{old}} \times 100\% = \frac{13 \frac{1}{3} - 10}{10} \times 100\% = 33 \frac{1}{3}\%$

This question could also have been solved algebraically by converting the percent increases into fractions.

Last year:  $pq = b$ , so  $q = b/p$

This year:  $(\frac{6}{5})(p)(x) = (\frac{8}{5})b$

If we solve for  $x$  (this year's quantity), we get  $x = (\frac{8}{5})(\frac{5}{6})b/p$  or  $(\frac{4}{3})b/p$

If this year's quantity is  $\frac{4}{3}$  of last year's quantity ( $b/p$ ), this represents a  $33 \frac{1}{3}\%$  increase.

The correct answer is A.

5.

This problem can be solved most easily with the help of smart numbers. With problems involving percentages, 100 is typically the 'smartest' of the smart numbers.

If we assume that today's population is 100, next year it would be  $1.1 \times 100 = 110$ , and the following year it would be  $1.1 \times 110 = 121$ . If this is double the population of one year ago, the population at that time must have been  $0.5 \times 121 = 60.5$ . Because the problem seeks the "closest" answer choice, we can round 60.5 to 60.

In this scenario, the population has increased from 60 to 100 over the last year, a net increase of 40 residents. To determine the percentage increase over the last year, divide the net increase by the initial population:  $40/60 = 4/6 = 2/3$ , or roughly 67%.

For those who prefer the algebraic approach: let the current population equal  $p$ . Next year the population will equal  $1.1p$ , and the following year it will equal  $1.1 \times 1.1p = 1.21p$ . Because the question asks for the closest answer choice, we can simplify our algebra by rounding  $1.21p$  to  $1.2p$ . Half of  $1.2p$  equals  $0.6p$ . The population increase would be equal to  $0.4p/0.6p = 0.4/0.6 = 2/3$ , or roughly 67%.

The correct answer is D.

6.

To solve this problem, first find the wholesale price of the shirt, then compute the price required for a 100% markup, then subtract the \$45 initial retail price to get the required increase.

Let  $x$  equal the wholesale price of the shirt. The retailer marked up the wholesale price by 80% so the initial retail price is  $x + (80\% \text{ of } x)$ . The following equation expresses the relationship mathematically:

$$x + 0.80x = 45$$

$$1.8x = 45$$

$$x = 45/1.8$$

$$x = 450/18$$

$$x = 25$$

Since the wholesale price is \$25, the price for a 100% markup is \$50. Therefore the retailer needs to increase the \$45 initial retail price by \$5 to achieve a 100% markup.

The correct answer is E.

7.

We can solve this as a VIC (Variable In answer Choices) and plug in values for  $x$  and  $r$ .

$R$	cents per person per mile	10
$X$	# of miles	20

Since there are 3 people, the taxi driver will charge them 30 cents per mile.

Since they want to travel 20 miles, the total charge (no discount) would be  $(30)(20) = 600$ .

With a 50% discount, the total charge will be 300 cents or 3 dollars.

If we plug  $r = 10$  and  $x = 20$  into the answer choices, the only answer that yields 3 dollars is D.

The correct answer is D.

8.

Bob put 20 gallons of gasohol into his car's gas tank, consisting of 5% ethanol and 95% gasoline. Chemical Mixture questions can be solved by using a mixture chart.

SUBSTANCES	AMOUNT	PERCENTAGE
------------	--------	------------

ETHANOL	1	5%
GASOLINE	19	95%
TOTALS	20	100%

This chart indicates that there is 1 gallon of ethanol out of the full 20 gallons, since 5% of 20 gallons is 1 gallon.

Now we want to add  $x$  gallons of ethanol to raise it to a 10% ethanol mixture. We can use another mixture chart to represent the altered solution.

SUBSTANCES	AMOUNT	PERCENTAGE
ETHANOL	$1 + x$	10%
GASOLINE	19	90%
TOTALS	$20 + x$	100%

Therefore, the following equation can be used to solve for  $x$ :

$$\frac{1 + x}{20 + x} = 10\%$$

$$1 + x = 2 + 0.1x$$

$$0.9x = 1$$

$$x = 10/9$$

The correct answer is C.

9. Noting that 65% is very close to  $2/3$ , we may approximate the original expression as follows:

$$1/3 + 0.4 + 65\% \quad \text{Original expression}$$

$$1/3 + 0.4 + 2/3 \quad \text{Close approximation}$$

$$1 + 0.4$$

$$1.4$$

The correct answer is D.

10.

First, let's find the initial amount of water in the tank:

$$\text{Total mixture in the tank} = 1/4 \times (\text{capacity of the tank}) = (1/4) \times 24 = 6 \text{ gallons}$$

$$\text{Concentration of water in the mixture} = 100\% - (\text{concentration of sodium chloride}) = 100\% - 40\% = 60\%$$

Initial amount of water in the tank =  $60\% \times (\text{total mixture}) = 0.6 \times 6 = 3.6$  gallons

Next, let's find the amount and concentration of water after 2 hours:

Amount of water that will evaporate in 2 hours =  $(\text{rate of evaporation})(\text{time}) = 0.5(2) = 1$  gallon

Remaining amount of water = initial amount – evaporated water =  $3.6 - 1 = 2.6$  gallons

Remaining amount of mixture = initial amount – evaporated water =  $6 - 1 = 5$  gallons

Concentration of water in the mixture in 2 hours =  $\frac{\text{remaining water}}{\text{remaining mixture}} \times 100\%$

which equals:  $\frac{2.6}{5} \times 100\% = 52\%$

The correct answer is C.

11.

One of the most effective ways to solve problems involving formulas is to pick numbers. Note that since we are not given actual values but are asked to compute only the relative change in the useful life, we can select easy numbers and plug them into the formula to compute the percentage increase. Let's pick  $d = 3$  and  $h = 2$  to simplify our computations:

Before the change:  $d = 3, h = 2; u = (8)(3)/2^2 = 24/4 = 6$

After the change:  $d = (2)(3) = 6, h = 2/2 = 1; u = (8)(6)/1^2 = 48$

Finally, percent increase is found by first calculating the change in value divided by the original value and then multiplying by 100:

$(48 - 6)/6 = (42/6) = 7$

$(7)(100) = 700\%$

The correct answer is D.

12.

Since there are variables in the answer choices, as well as in the question stem, one way to approach this problem is to pick numbers and test each answer choice. We know that  $x$  is  $m$  percent of  $2y$ , so pick values for  $m$  and  $y$ , then solve for  $x$ .

$y = 100$

$m = 40$

$x$  is  $m$  percent of  $2y$ , or  $x$  is 40 percent of 200, so  $x = (0.40)(200) = 80$ .

So, for the numbers we are using,  $m$  is what percent of  $x$ ? Well,  $m = 40$ , which is half of  $x = 80$ . Thus,  $m$  is 50 percent of  $x$ . The answer choice that equals 50 will be the correct choice.

- (A)  $y/200 = 100/200 = 0.5$  WRONG
- (B)  $2y = (2)(100) = 200$  WRONG
- (C)  $50y = (50)(100) = 5000$  WRONG
- (D)  $50/y = 50/100 = 0.5$  WRONG
- (E)  $5000/y = 5000/100 = 50$  CORRECT

Alternatively, we can pursue an algebraic solution.

We are given the fact that  $x$  is  $m$  percent of  $2y$ , or  $x = (m/100)(2y) = my/50$ . Since the question asks about  $m$  (" $m$  is what percent of  $x$ ?"), we should solve this equation for  $m$  to get  $m = (50/y)(x)$ .

Putting the question " $m$  is what percent of  $x$ ?" into equation form, with the word "*Answer*" as a placeholder,  $m = (Answer/100)(x)$ .

Now we have two equations for  $m$ . If we set them equal, we can solve for the "*Answer*."

$$(Answer/100)(x) = (50/y)(x)$$
$$(Answer/100) = (50/y)$$
$$Answer = 5000/y$$

The correct answer is E.

13.

The easiest way to solve this problem is to use the VIC method of substituting actual numbers for  $x$  and  $y$ . The problem asks us to take  $x\%$  of  $y$  and increase it by  $x\%$ . Since we are dealing with percentages, and the whole ( $y$ ) is neither given to us nor asked of us, let's set  $y = 100$  and  $x = 10$ . Note that this is a variation on the typical method of picking small numbers in VIC problems.

10% of 100 is 10. Increasing that 10 by 10% gives us  $10 + 1 = 11$ . Therefore 11 is our target number. Let's test each answer choice in turn to see which of them matches our target number.

- (A)  $100xy + x = 100(10)(100) + 10$  which doesn't equal 11.
- (B)  $xy + x/100 = 10(100) + 10/100$  which doesn't equal 11.
- (C)  $100xy + x/100 = 100(10)(100) + 10/100$  which doesn't equal 11.

$$(D) 100xy + \frac{xy}{100}$$

$$= 100(10)(100) + \frac{10(100)}{100} \text{ which doesn't equal 11.}$$

$$(E) \frac{xy(x+100)}{10000} =$$

$$(10)(100)(10+100)$$

$$\frac{\quad}{10000} =$$

$$\frac{10+100}{10} = 11$$

The correct answer is E.

14.

Given an initial deposit of \$1,000, we must figure out the ending balance to calculate the total percent change.

After the first year, Sam's account has increased by \$100 to \$1,100.

After the second year, Sam's account again increased by 10%, but we must take 10% of \$1,100, or \$110. Thus the ending balance is \$1,210 (\$1,100 + \$110).

To calculate the percent change, we first calculate the difference between the ending balance and the initial balance: \$1,210 - \$1,000 = \$210. We divide this difference by the initial balance of \$1,000 and we get \$210/\$1,000 = .21 = 21%.

The correct answer is C.

15.

Problems that involve successive price changes are best approached by selecting a smart number. When the problem deals with percentages, the most convenient smart number to select is 100. Let's assign the value of 100 to the initial price of the painting and perform the computations:

Original price of the painting = 100.

Price increase during the first year = 20% of 100 = 20.

Price after the first year =  $100 + 20 = 120$ .  
 Price decrease during the second year =  $15\%$  of  $120 = 18$ .  
 Price after the second year =  $120 - 18 = 102$ .  
 Final price as a percent of the initial price =  $(102/100) = 1.02 = 102\%$ .

The correct answer is A.

16.

We can solve this question as a VIC (Variable in answer choices) by plugging in values for  $x$ ,  $y$  and  $z$ :

$x$	percent mark-up (1st)	10
$y$	percent discount (2nd)	20
$z$	original price	100

If a \$100 item is marked up 10% the price becomes \$110. If that same item is then reduced by 20% the new price is \$88.

If we plug  $x = 10$ ,  $y = 20$ ,  $z = 100$  into the answer choices, only answer choice (A) gives us 88:

$$\frac{10,000(100) + 100(100)(10 - 20) - (10)(20)(100)}{10,000} = 88$$

Alternatively we could have solved this algebraically.

A price markup of  $x$  percent is the same as multiplying the price  $z$  by  $(1 + \frac{x}{100})$ .

A price discount of  $y$  percent is the same as multiplying by  $(1 - \frac{y}{100})$ .

We can combine these as:  $z(1 + x/100)(1 - y/100)$ .

$$10,000z + 100z(x - y) - xyz$$

This can be simplified to:

$$\frac{10,000z + 100z(x - y) - xyz}{10,000}$$

The correct answer is A.

17.

If  $p$  is the price that the shop originally paid for the clock, then the price that the collector paid was  $1.2p$  (to yield a profit of 20%). When the shop bought back the clock, it paid 50% of the sale price, or  $(.5)(1.2)p = .6p$ . When the shop sold the clock again, it made a profit of 80% on  $.6p$  or  $(1.8)(.6)p = 1.08p$ .

The difference between the original cost to the shop ( $p$ ) and the buy-back price ( $.6p$ ) is \$100.

Therefore,  $p - .6p = \$100$ . So,  $.4p = \$100$  and  $p = \$250$ .

If the second sale price is  $1.08p$ , then  $1.08(\$250) = \$270$ . (Note: at this point, if you recognize that  $1.08p$  is greater than \$250 and only one answer choice is greater than \$250, you may choose not to complete the final calculation if you are pressed for time.)

The correct answer is A.

18.

We are told that the boys of Jones Elementary make up 40% of the total of  $x$  students.

Therefore: # of boys =  $.4x$

We are also told that  $x\%$  of the # of boys is 90.

Thus, using  $x/100$  as  $x\%$ :

$$(x/100) \times (\# \text{ of boys}) = 90$$

Substituting for # of boys from the first equation, we get:

$$(x/100) \times .4x = 90$$

$$(.4x^2) / 100 = 90$$

$$.4x^2 = 9,000$$

$$x^2 = 22,500$$

$$x = 150$$

Alternatively, we could have plugged in each answer choice until we found the correct value of  $x$ . Because the answer choices are ordered in ascending order, we can start with answer choice C. That way, if we get a number too high, we can move to answer choice B and if we get a number too low, we can move to answer choice D.

Given an  $x$  of 225 in answer choice C, we first need to take 40%. We do this by multiplying by .4.

$$.4 \times 225 = 90$$

Now, we need to take  $x\%$  of this result. Again,  $x\%$  is just  $x/100$ , in this case  $225/100$  or 2.25.

Thus  $x\%$  of our result is:  $2.25 \times 90 = 202.5$

This is too high so we try answer choice B. Following the same series of calculations we get:

$$.4 \times 150 = 60$$

$$x\% = 150/100 = 1.5$$

$$1.5 \times 60 = 90$$

This is the result we are looking for, so we are done.

The correct answer is B.

19.

If we denote the amount of money owned by Jennifer as  $j$  and that owned by Brian as  $b$ , we can create two equations based on the information in the problem. First, Jennifer has 60 dollars more than Brian:  $j = b + 60$ .

Second, if she were to give Brian  $1/5$  of her money, she would have  $j - (1/5)j = (4/5)j$  dollars. Brian would then have  $b + (1/5)j$  dollars. Therefore, since Brian's amount of money would be 75% of Jennifer's, we can create another equation:  $b + (1/5)j = (0.75)(4/5)j$ , which can be simplified as follows:

$$b + (1/5)j = (0.75)(4/5)j$$

$$b + (1/5)j = (3/4)(4/5)j$$

$$b + (1/5)j = (3/5)j$$

$$b = (3/5)j - (1/5)j$$

$$b = (2/5)j$$

Substitute this expression for  $b$  back into the first equation, then solve for  $j$ :

$$j = b + 60$$

$$j = (2/5)j + 60$$

$$j - (2/5)j = 60$$

$$(3/5)j = 60$$

$$j = (60)(5/3) = 100$$

Therefore, Jennifer has 100 dollars.

The correct answer is B.

20.

In this case, the average computer price three years ago represents the original amount. The original amount = 80% of \$700 or \$560. The *change* is the difference between the original and new prices = \$700 - \$560 = \$140. % change = 25%. The correct answer is C.

21.

To determine the total capacity of the pool, we need to first determine the amount of water in the pool *before* the additional water is added. Let's call this amount  $b$ .

Adding 300 gallons represents a 30% increase over the original amount of water in the pool. Thus,  $300 = 0.30b$ . Solving this equation, yields  $b = 1000$ . There are 1000 gallons of water originally in the pool.

After the 300 gallons are added, there are 1300 gallons of water in the pool. This represents 80% of the pool's total capacity,  $T$ .

$$1300 = .80T$$

$$1300 = (4/5)T$$

$$1300(5/4) = T$$

$$T = 1625$$

The correct answer is E

22. Instead of performing the computation, set up a fraction and see if terms in the numerator cancel out terms in the denominator: Notice that the 16 cancels out the two 4s and that the 1000 in the numerator cancels the 1000 in the denominator. Thus, we are left with  $2 \times 3 \times 3 = 18$ . This is the equivalent of  $1.8 \times 10$ . The correct answer is D.

23.

We are asked to find the dollar change in the price of the property during the second year. Since we know the percent changes in each year, we will be able to answer the question if we know the price of the property in any of these years, or, alternatively, if we know the dollar change in the property price in any particular year.

(1) SUFFICIENT: Since we know the price of the property at the end of the three-year period, we can find the original price and determine the price increase during the second year. Let  $p$  denote the original price of the property:

$$p(1.1)(0.8)(1.25) = 22,000$$

$$1.1p = 22,000$$

$$p = 20,000$$

Price of the property after the first year:  $20,000(1.1) = 22,000$

Price of the property after the second year:  $22,000(0.8) = 17,600$

Decrease in the property price =  $22,000 - 17,600 = 4,400$

(2) SUFFICIENT: This information is sufficient to create an equation to find the original price and determine the dollar change during the second year:

Price at the end of the first two years:  $p(1.1)(0.8) = 0.88p$

Price decrease over the two-year period = original price – ending price =  $p - 0.88p = 0.12p$

Price increase in the third year = (price at the end of two years)(25%) =  $0.88p(0.25) = 0.22p$

Thus, since we know that the difference between the price decrease over the first two years and the price increase over the third year was \$2,000, we can create the following equation and solve for  $p$ :

$$0.22p - 0.12p = 2,000$$

$$0.1p = 2,000$$

$$p = 20,000$$

Price of the property after the first year:  $20,000(1.1) = 22,000$

Price of the property after the second year:  $22,000(0.8) = 17,600$

Decrease in the property price = 4,400

The correct answer is D.

24.

Let  $i$  be the salesman's income, let  $s$  be the salary, and let  $c$  be the commission. From the question stem we can construct the following equation:

$$i = s + c$$

We are asked whether  $s$  accounts for more than half of  $i$ . We can thus rephrase the question as "Is  $s$  greater than  $c$ ?"

SUFFICIENT: This allows us to construct the following equation:

$$1.1i = s + 1.3c$$

Since we already have the equation  $i = s + c$ , we can subtract this equation from the one above:

$$.1i = .3c$$

Notice that the  $s$ 's cancel each other out when we subtract. We can isolate the  $c$  by multiplying both sides by  $10/3$  (the reciprocal of  $.3$  or  $3/10$ ):

$$(1/10)i = (3/10)c$$

$$(1/10)i \times (10/3) = (3/10)c \times (10/3)$$

$$(1/3)i = c$$

Therefore  $c$  is one-third of the salesman's income. This implies that the salary must account for two-thirds of the income. Thus, we can answer definitively that the salary accounts for more than half of the income.

INSUFFICIENT: Either  $s - c = .5s$  or  $c - s = .5s$ . Coupled with our knowledge that  $s$  and  $c$  must add to 100% of the salesman's income, we can say that one of the two is worth 75% of the income and the other is worth 25%. However, we don't know which is the bigger number:  $s$  or  $c$ .

The correct answer is A.

25. We can determine the sales revenue that the sales associate generated by analyzing her commission earnings for the week.

SUFFICIENT: The sales associate earned a total of \$1500 in commission last week. We know that on the first \$10,000 in sales revenue, the associate earns 8% or \$800 in commission. This means that the associate earned \$700 in additional commission. Since this additional commission is calculated based on a 10% rate, the sales associate must have generated an additional \$7000 worth of sales revenue. Thus, we know from statement 1 that the sales associate generated  $\$10,000 + \$7000 = \$17,000$  in sales revenue last week. Statement 1 alone is sufficient.

SUFFICIENT: The sales associate was eligible for the 10% commission rate on \$7000 worth of sales. Since the 10% rate only kicks in after the first \$10,000 in sales, this means that the sales associate generated \$7000 in sales revenue *above* the \$10,000 threshold. Thus, we know from statement 2 that the sales associate generated  $\$10,000 + \$7000 = \$17,000$  in sales revenue last week. Statement 2 alone is sufficient.

The correct answer is D.

26.

Let  $x$  represent the company's profits in 1992,  $y$  represent the profits in 1993, and  $z$  represent the profits in 1994. Since the profits in 1993 were 20% greater than in 1992,  $y = 1.2x$ , or  $y/x = 1.2$ . Similarly, since the profits in 1994 were 10% greater than in 1993,  $z = 1.1y$ , or  $z/y = 1.1$ . Since we have ratios relating the three variables, knowing the profits from any of the three years will allow us to calculate the profits in 1992. So, the rephrased question is: "What is  $x$ ,  $y$ , or  $z$ ?"

(1) SUFFICIENT: This statement tells us that  $z = 100,000 + y$ . We also know the ratio of  $z$  to  $y$ :  $z/y = 1.1$ . Combining the two equations and substituting for  $z$  gives:

$$\begin{aligned}z/y &= 1.1 \\(100,000 + y)/y &= 1.1 \\100,000 + y &= 1.1y \\100,000 &= .1y \\y &= 1,000,000\end{aligned}$$

The profits in 1993 were \$1,000,000. Since we know  $y = 1.2x$ , this information is sufficient to determine the profits in 1992.

(2) INSUFFICIENT: This tells us that the ratio of  $z$  to  $x$  is:  $z/x = 3.96/3 = 1.32$ . However, we already know from information given in the question that:

$$\begin{aligned}y &= 1.2x \text{ and } z = 1.1y \\z &= 1.1(1.2x) \\z &= 1.32x \\z/x &= 1.32\end{aligned}$$

So, statement (2) gives no new information.

The correct answer is A.

27.

In order to determine the percent discount received by Jamie, we need to know two things: the regular price of the desk and the sale price of the desk. Alternatively, we could calculate the percent discount from the price reduction and either the regular price or the sale price.

(1) INSUFFICIENT: This statement tells us the regular price of the desk at Al's, but provides no information about how much Jamie actually paid for the desk during the annual sale.

(2) INSUFFICIENT: This statement tells us how much the price of the desk was reduced during the sale, but provides no information about the regular price. For example, if the regular price was \$6010, then the discount was only 10%. On the other hand, if the regular price was \$602, then the discount was nearly 100%.

(1) AND (2) INSUFFICIENT: At first glance, it seems that the statements together provide enough information. Statement (1) seems to provide the regular price of the desk, while statement (2) provides the discount in dollars.

However, pay attention to the words "rounded to the nearest percent" in statement (1). This indicates that the regular price of the desk at Al's is 60% of the MSRP, plus or minus 0.5% of the MSRP. Rather than clearly stating that the regular price is  $(0.60)(\$2000) = \$1200$ , this statement gives a range of values for the regular price: \$1200 plus or minus \$10 (0.5% of 2000), or between \$1190 and \$1210.

If the regular price was \$1190, then the discount was  $(\$601/\$1190) \times 100\% = 50.5\%$  (you can actually see that this is greater than 50% without calculating).

If the regular price was \$1210, then the discount was  $(\$601/\$1210) \times 100\% = 49.7\%$  (you can actually see that this is less than 50% without calculating).

The uncertainty about the regular price means that we cannot answer with certainty whether the discount was more than 50% of the regular price.

The correct answer is E.

28.

According to the question stem,  
total cost = fixed cost + variable cost

$$C_t = C_f + C_v$$

The question is asking for the percent change of the total cost of production of item X in January. Clearly if we knew the total cost of producing X before January and then in January, we could calculate the percent change. From the question, however, it doesn't seem like we will be provided with this information.

(1) INSUFFICIENT: Since the total cost of production is also the sum of the fixed and variable costs, it would stand to reason that we should be able to calculate the percent change to the total cost if we knew the percent change of the fixed and variable costs.

However, it is not that simple. We cannot simply average the percent change of the fixed and variable costs to find the percent change of the total cost of production. Two percents cannot be averaged unless we know what relative portions they represent.

Let's use numbers to illustrate this point. In the first set of numbers in the table below, the fixed cost is 100 times the size of the variable cost. Notice that the percent change of the total cost of production is almost identical to the percent change of the fixed cost. In the second set of numbers, the fixed and variable costs are identical. Notice that the percent change of the total cost of production is exactly the average of the percent change of the variable cost and the fixed cost (4% is the average of 13% and -5%).

	Before	In January	TOTALS
$C_f$	100	113	+ 13%
$C_v$	1	.95	- 5%
$C_t$	101	113.95	$\approx$ +13%
$C_f$	100	113	+ 13%
$C_v$	100	95	- 5%
$C_t$	200	208	+ 4%

(2) INSUFFICIENT: Lacking information about the percent change of the fixed cost, we cannot solve.

(1) AND (2) SUFFICIENT: Using the two statements, we not only have the percent changes of the fixed and variable percents, but we also know the relative portions they represent.

If the fixed cost before January was five times that of the variable cost, we can calculate the percent change to the cost of production using a weighted average:

$$\text{Percent change of } C_t = \frac{(5 \times \text{percent change of } C_f) + (1 \times \text{percent change of } C_v)}{6}$$

$$\text{Percent change of } C_t = \frac{(5 \times 13\%) + (1 \times -5\%)}{6} = 10\%$$

Alternatively if we try different values for  $C_f$  and  $C_v$  that each maintain the 5:1 ratio, we will come up with the same result. The cost of production increased in January by 10%.

The correct answer is C.

### 29.

This problem can be conceptualized with the help of smart numbers and some simple algebra. Because we are working with percentages and are given no real values, it is sensible to begin with the assumption that there are 100 attendees at the party. Therefore, there must be 40 females and 60 males.

Let  $m$  equal the number of men who arrived solo,  $w$  equal the number of women who arrived solo, and  $p$  equal the number of attendees who arrived with a companion ( $p/2$  would equal the number of pairs). Using our smart numbers assumption,  $m + w + p = 100$ . This question might therefore be rephrased, "What is  $m + w$ ?" or "What is  $100 - p$ ?"

(1) SUFFICIENT: Given 60 male guests, Statement (1) tells us that 30 arrived with a companion. Therefore, 30 men and 30 women arrived in pairs. Recall that  $p$  equals the total number of guests arriving in pairs, so  $p = 60$ . Given that  $100 - p$  is sufficient to solve our problem, Statement (1) is sufficient: 40 individuals (40% of the total number of guests) arrived at the party alone.

(2) SUFFICIENT: This statement tells us that

$$\begin{aligned} .25(m + w) &= w \\ .25m + .25w &= w \\ .25m &= .75w \\ m &= 3w \end{aligned}$$

Further, observe that the total number of women at the party would equal the number arriving solo plus the number arriving with a companion:

$$\begin{aligned} 40 &= w + p/2 \\ 80 &= 2w + p \end{aligned}$$

Finally, recall that  $m + w + p = 100$ .

We now have three equations with three unknowns and are able solve for  $m$ ,  $w$  and  $p$ , so Statement (2) is sufficient. While it is unnecessary to complete the algebra for this data sufficiency problem, witness:

Substituting  $3w$  for  $m$  in the equation  $m + w + p = 100$  yields  $4w + p = 100$ .

$$2w + p = 80$$

$$4w + p = 100$$

Subtracting the first equation from the second yields

$$2w = 20$$

$$w = 10$$

$$p = 60$$

$$m = 30$$

The correct answer is D.

30.

In order to answer this question, we must determine the value of  $a^b$ .

INSUFFICIENT: This tells us that  $b = 2a$ . However, this does not allow us to solve for  $a^b$ .

INSUFFICIENT: This tells us that  $.5b = a$ . This can be rewritten as  $b = 2a$ . However, this does not allow us to solve for  $a^b$ .

AND (2) INSUFFICIENT: Since both statements provide the exact same information, taking the two together still does not allow us to solve for  $a^b$ .

The correct answer is E.

**31.**

Let their hourly wage are  $x$  and  $y$ .

Therefore, after the increases, the difference between their wages is  $1.06x - 1.06y$

From 1,  $x - y = 5$ , we can solve out  $1.06x - 1.06y$

From 2,  $x/y = 4/3$ , insufficient.

Answer is A

**32.**

Let  $M$  be the number of the cameras produced in 1995.

$$[M/(1+y\%)]/(1+x\%) = 1000$$

$$M = 1000 + 10x + 10y + xy/10$$

Knowing that  $x + y + xy/100 = 9.2$ ,  $M$  can be solve out.

Answer is B

**33.**

Let  $x$  and  $y$  be the numbers of the male and female students.

Combined 1 and 2,  $35\%X + 20\%Y = 25\%(X + Y)$

$10\%X = 5\%Y$

$Y = 2X$

$X/(X + Y) = X/3X = 1/3$

Answer is C

**34.**

We know that: revenue = gross profit + expense

1). Revenue =  $1/3$  expense + expense =  $4/3$  expense, gross profit is  $1/4$  of its revenue.

2). Gross profit = revenue - expense =  $1/4$  revenue, gross profit is  $1/4$  of its revenue.

Answer is D

**35.**

let  $y = x$ , the number of people working more than 10 years = 560

$(560 - x)/(800 - x) = 60\% \Rightarrow x = 200$

**36.**

$(150 + \text{profit}) * 40\% = \text{profit}$

So, the profit is \$100

**37.**

The profit is sale price - cost

For one stock, (sale price - cost)/cost = 20%, its cost is  $96/1.2 = 80$

For the other stock, (sale price - cost)/cost = -20%, cost is  $96/0.8 = 120$

Then, the total profit for the two stocks is:

$96 - 80 + 96 - 120 = -8$

Answer is C

# Work / Rate

1.

Let  $a$  be the number of hours it takes Machine A to produce 1 widget on its own. Let  $b$  be the number of hours it takes Machine B to produce 1 widget on its own.

The question tells us that Machines A and B together can produce 1 widget in 3 hours. Therefore, in 1 hour, the two machines can produce  $1/3$  of a widget. In 1 hour, Machine A can produce  $1/a$  widgets and Machine B can produce  $1/b$  widgets. Together in 1 hour, they produce  $1/a + 1/b = 1/3$  widgets.

If Machine A's speed were doubled it would take the two machines 2 hours to produce 1 widget. When one doubles the speed, one cuts the amount of time it takes in half. Therefore, the amount of time it would take Machine A to produce 1 widget would be  $a/2$ . Under these new conditions, in 1 hour Machine A and B could produce  $1/(a/2) + 1/b = 1/2$  widgets. We now have two unknowns and two different equations. We can solve for  $a$ .

The two equations:

$$2/a + 1/b = 1/2 \text{ (Remember, } 1/(a/2) = 2/a)$$

$$1/a + 1/b = 1/3$$

Subtract the bottom equation from the top:

$$2/a - 1/a = 1/2 - 1/3$$

$$1/a = 3/6 - 2/6$$

$$1/a = 1/6$$

Therefore,  $a = 6$ .

The correct answer is E.

2.

Because Adam and Brianna are working together, add their individual rates to find their combined rate:

$$50 + 55 = 105 \text{ tiles per hour}$$

The question asks how long it will take them to set 1400 tiles.

$$\text{Time} = \text{Work} / \text{Rate} = 1400 \text{ tiles} / (105 \text{ tiles} / \text{hour}) = 40/3 \text{ hours} = 13 \text{ and } 1/3 \text{ hours} = 13 \text{ hours and } 20 \text{ minutes}$$

The correct answer is C.

3.

To find the combined rate of the two machines, add their individual rates:

$$35 \text{ copies/minute} + 55 \text{ copies/minute} = 90 \text{ copies/minute.}$$

The question asks how many copies the machines make in half an hour, or 30 minutes.

$$90 \text{ copies/minute} \times 30 \text{ minutes} = 2,700 \text{ copies.}$$

The correct answer is B.

4.

Tom's individual rate is 1 job / 6 hours or  $1/6$ .

During the hour that Tom works alone, he completes  $1/6$  of the job (using  $rt = w$ ).

Peter's individual rate is 1 job / 3 hours.

Peter joins Tom and they work together for another hour; Peter and Tom's respective individual rates can be added together to calculate their combined rate:  
 $1/6 + 1/3 = 1/2$ .

Working together then they will complete  $1/2$  of the job in the 1 hour they work together.

At this point,  $2/3$  of the job has been completed ( $1/6$  by Peter alone +  $1/2$  by Peter and Tom), and  $1/3$  remains.

When John joins Tom and Peter, the new combined rate for all three is:  $1/6 + 1/3 + 1/2 = 1$ .

The time that it will take them to finish the remaining  $1/3$  of the job can be solved:

$$rt = w \longrightarrow (1)(t) = 1/3 \longrightarrow t = 1/3.$$

The question asks us for the fraction of the job that Peter completed. In the hour that Peter worked with Tom he alone completed:  $rt = w \longrightarrow w = (1/3)(1) = 1/3$  of the job.

In the last  $1/3$  of an hour that all three worked together, Peter alone completed:  $(1/3)(1/3) = 1/9$  of the job.

Adding these two values together, we get  $1/3 + 1/9$  of the job =  $4/9$  of the job.

The correct answer is E.

5.

We can solve this problem as a VIC (Variable In answer Choice) and plug in values for the variable  $x$ . Let's say  $x = 6$ . (Note that there is a logical restriction here in terms of the value of  $x$ . Lindsay has to have a rate of less than less than 1 room per hour if she needs Joseph's help to finish in an hour).

If Lindsay can paint  $1/6$  of the room in 20 minutes ( $1/3$  of an hour), her rate is  $1/2$ .

$$rt = w$$

$$r(1/3) = 1/6$$

$$r = 1/2$$

Let  $J$  be the number of hours it takes Joseph to paint the entire room. Joseph's rate then is  $1/J$ . Joseph and Lindsay's combined rate is  $1/2 + 1/J$ , which can be simplified:

$$1/2 + 1/J \longrightarrow J/2J + 2/2J \longrightarrow (J + 2)/2J$$

If the two of them finish the room in one hour, using the formula of  $rt = w$ , we can solve for  $J$ .

$$rt = w \text{ and } t = 1 \text{ (hour), } w = 1 \text{ (job)}$$

$$((J + 2)/2J)(1) = 1 \longrightarrow J + 2 = 2J \longrightarrow J = 2$$

That means that Joseph's rate is  $1/2$ , the same as Lindsay's. The question though asks us what fraction of the room Joseph would complete in 20 minutes, or  $1/3$  of an hour.

$$rt = w$$

$$(1/2)(1/3) = w$$

$$w = 1/6$$

Now we must look at the answer choices to see which one is equal to  $1/6$  when we plug in  $x = 6$ . Only C works:  $(6 - 3) / 18 = 1/6$ .

The correct answer is C.

6.

The combined rate of individuals working together is equal to the sum of all the individual working rates.

Let  $s$  = rate of a smurf,  $e$  = rate of an elf, and  $f$  = rate of a fairy. A rate is expressed in terms of treehouses/hour. So for instance, the first equation below says that a smurf and an elf working together can build 1 treehouse per 2 hours, for a rate of  $1/2$  treehouse per hour.

$$s + e = 1/2$$

$$2) s + 2f = 1/2$$

$$e + f = 1/4$$

The three equations can be combined by solving the first one for  $s$  in terms of  $e$ , and the third equation for  $f$  in terms of  $e$ , and then by substituting both new equations into the middle equation.

$$1) s = 1/2 - e$$

$$2) (1/2 - e) + 2(1/4 - e) = 1/2$$

$$3) f = 1/4 - e$$

Now, we simply solve equation 2 for  $e$ :

$$(1/2 - e) + 2(1/4 - e) = 1/2$$

$$2/4 - e + 2/4 - 2e = 2/4$$

$$4/4 - 3e = 2/4$$

$$-3e = -2/4$$

$$e = 2/12$$

$$e = 1/6$$

Once we know  $e$ , we can solve for  $s$  and  $f$ :

$$s = 1/2 - e$$

$$s = 1/2 - 1/6$$

$$s = 3/6 - 1/6$$

$$s = 2/6$$

$$s = 1/3$$

$$f = 1/4 - e$$

$$f = 1/4 - 1/6$$

$$f = 3/12 - 2/12$$

$$f = 1/12$$

We add up their individual rates to get a combined rate:

$$e + s + f =$$

$$1/6 + 1/3 + 1/12 =$$

$$2/12 + 4/12 + 1/12 = 7/12$$

Remembering that a rate is expressed in terms of treehouses/hour, this indicates that a smurf, an elf, and a fairy, working together, can produce 7 treehouses per 12 hours. Since we want to know the number of hours per treehouse, we must take the reciprocal of the rate. Therefore we conclude that it takes them 12 hours per 7

treehouses, which is equivalent to  $12/7$  of an hour per treehouse. The correct answer is D.

7.

Since this is a work rate problem, we'll use the formula  $rate \times time = work$ . Since we'll be calculating times, we'll use it in the form  $time = work / rate$ .

First let  $T_0$  equal the time it takes to paint the houses under the speedup scenario.  $T_0$  will equal the sum of the following two values:

1. the time it takes to paint  $y$  houses at a rate of  $x$
2. the time it takes to paint  $(80 - y)$  houses at a rate of  $1.25x$ .

$$T_0 = \frac{y}{x} + \frac{(80 - y)}{1.25x}$$

$$T_0 = \frac{1.25x}{(80 + 0.25y)} + 1.25x$$

$$T_0 = \frac{1.25x}{1.25x}$$

Then let  $T_1$  equal the time it takes to paint all 80 houses at the steady rate of  $x$ .

$$T_1 = \frac{80}{x}$$

The desired ratio is  $\frac{T_0}{T_1}$ . This equals  $T_0$  times the reciprocal of  $T_1$ .

$$\frac{T_0}{T_1} = \frac{80 + 0.25y}{1.25x} \times \frac{x}{80}$$

$$\frac{T_0}{T_1} = \frac{80 + 0.25y}{100}$$

$$\frac{T_0}{T_1} = \frac{0.8 + 0.0025y}{y}$$

As a quick check, note that if  $y = 80$ , meaning they paint ALL the houses at rate  $x$  before bringing in the extra help, then  $T_0/T_1 = 1$  as expected.

The correct answer is B.

8.

There are several ways to achieve sufficiency in solving this rate problem, so the question cannot be rephrased in a useful manner.

(1) INSUFFICIENT: This statement provides the difference between the number of hot dogs consumed by the third-place finisher (let's call this  $t$ ) and the number of hot dogs consumed by the winner (let's call this  $w$ ). We now know that  $w = t + 24$ , but this does not provide sufficient information to solve for  $w$ .

(2) INSUFFICIENT: The third-place finisher consumed one hot dog per 15 seconds. To simplify the units of measure in this problem, let's restate this rate as 4 hot dogs per minute. Statement (2) tells us that the winner consumed 8 hot dogs per minute. This does not provide sufficient information to solve for  $w$ .

(1) AND (2) SUFFICIENT: The rate of consumption multiplied by elapsed time equals the number of hot dogs consumed. This equation can be restated as  $\text{time} = \text{hot dogs}/\text{rate}$ . Because the elapsed time is equal for both contestants, we can set the hot dogs/rate for each contestant equal to one another:

$$\begin{aligned}w/8 &= t/4 \\w &= 2t\end{aligned}$$

Substituting  $w - 24$  for  $t$  yields

$$\begin{aligned}w &= 2(w - 24) \\w &= 2w - 48 \\48 &= w\end{aligned}$$

The correct answer is C.

9.

This is a work problem. We can use the equation  $\text{Work} = \text{Rate} \times \text{Time}$  ( $W = R \times T$ ) to relate the three variables Work, Rate, and Time. The question asks us to find the number of newspapers printed on Sunday morning. We can think of the "number of newspapers printed" as the "work done" by the printing press. So, the question is asking us to find the work done on Sunday morning, or  $W_{\text{sunday}}$ .

The printing press runs from 1:00 AM to 4:00 AM on Sunday morning, so  $T_{\text{sunday}} = 3$

hours. Since  $W_{\text{sunday}} = R_{\text{sunday}} \times T_{\text{sunday}}$ , or in this case  $W_{\text{sunday}} = R_{\text{sunday}} \times 3$ , knowing the rate of printing,  $R_{\text{sunday}}$ , will allow us to calculate  $W_{\text{sunday}}$  (the number of newspapers printed on Sunday morning). Therefore, the rephrased question becomes: What is  $R_{\text{sunday}}$ ?

(1) INSUFFICIENT: This statement tells us that  $R_{\text{saturday}} = 2R_{\text{sunday}}$ . While this relates Saturday's printing rate to Sunday's printing rate, it gives no information about the value of either rate.

(2) INSUFFICIENT: For Saturday morning,  $W_{\text{saturday}} = 4,000$  and  $T_{\text{saturday}} = 4$  hours. We can set up the following equation:

$$W_{\text{saturday}} = R_{\text{saturday}} \times T_{\text{saturday}}$$

$$4,000 = R_{\text{saturday}} \times 4$$

$$R_{\text{saturday}} = 1,000$$

This gives the rate of printing on Saturday morning, but fails to give any information about Sunday's rate.

(1) AND (2) SUFFICIENT: Statement (1) tells us that  $R_{\text{saturday}} = 2R_{\text{sunday}}$  and statement (2) tells us that  $R_{\text{saturday}} = 1,000$ . Putting this information together yields:

$$R_{\text{saturday}} = 2R_{\text{sunday}}$$

$$1,000 = 2R_{\text{sunday}}$$

$$500 = R_{\text{sunday}}$$

The correct answer is C.

## 10.

To find the combined rate of Machines A and B, we combine their individual rates. If

Machine A can fill an order of widgets in  $a$  hours, then in 1 hour it can fill  $\frac{1}{a}$  of the order. By the same token, if Machine B can fill the order of widgets in  $b$  hours, then

in 1 hour, it can fill  $\frac{1}{b}$  of the order. So together in 1 hour, Machines A and B can fill  $\frac{1}{a} + \frac{1}{b}$  of the order:

$$\frac{1}{a} + \frac{1}{b} = \frac{(b)1}{(b)(a)} + \frac{(a)1}{(a)(b)} = \frac{b}{ab} + \frac{a}{ab} = \frac{a+b}{ab}$$

So in 1 hour, Machines A and B can complete  $\frac{a+b}{ab}$  of the order. To find the number of hours the machines need to complete the *entire* order, we can set up the following equation:

(fraction of order completed in 1 hour) x (number of hours needed to complete entire order) = 1 order.

If we substitute  $\frac{a+b}{ab}$  for the fraction of the order completed in 1 hour, we get:

$\frac{a+b}{ab}(x) = 1$ , where  $x$  is the number of hours needed to complete the entire order. If

we divide both sides by  $\frac{a+b}{ab}$ , we get:

$$x = \frac{ab}{a+b}$$

In other words, it will take Machines A and B  $\frac{ab}{a+b}$  hours to complete the entire order working together at their respective rates.

The question stem tells us that  $a$  and  $b$  are both even integers. We are then asked whether  $a$  and  $b$  are equal. If they are equal, we can express each as  $2z$ , where  $z$  is a non-zero integer, because they are even. If we replace  $a$  and  $b$  with  $2z$  in the combined rate, we get:

$$\frac{(2z)(2z)}{2z+2z} = \frac{4z^2}{4z} = z$$

So if  $a$  and  $b$  are equal, the combined rate of Machines A and B must be an integer (since  $z$  is an integer). We can rephrase the question as:

Is the combined rate of Machines A and B an integer?

Statement 1 tells us that it took 4 hours and 48 minutes for the two machines to fill the order (remember, they began at noon). This shows that the combined rate of Machines A and B is NOT an integer (otherwise, it would have taken the machines a whole number of hours to complete the order). So we know that  $a$  and  $b$  cannot be the same. Sufficient.

Statement 2 tells us that  $(a+b)^2 = 400$ . Since both  $a$  and  $b$  must be positive (because they represent a number of hours), we can take the square root of both sides of the equation without having to worry about negative roots. Therefore, it must be true that

$a + b = 20$ . So it is possible that  $a = 10$  and that  $b = 10$ , which would allow us to answer "yes" to the question. But it is also possible that  $a = 12$  and  $b = 8$  (or any other combination of positive even integers that sum to 20), which would give us a "no". Insufficient.

The correct answer is A: Statement 1 alone is sufficient, but statement 2 alone is not.

11.

If water is rushing into tank 1 at  $x$  gallons per minute while leaking out at  $y$  gallons per minute, the net rate of fill of tank 1 is  $x - y$ . To find the time it takes to fill tank 1, divide the capacity of tank 1 by the rate of fill:  $z / (x - y)$ .

We know that the rate of fill of tank 2 is  $y$  and that the total capacity of tank 2 is twice the number of gallons remaining in tank 1 after one minute. After one minute, there are  $x - y$  gallons in tank 1, since the net fill rate is  $x - y$  gallons per minute. Thus, the total capacity of tank 2 must be  $2(x - y)$ .

The time it takes to fill tank two then is  $\frac{2(x - y)}{y}$ . The question asks us if tank 1 fills up before tank 2.

We can restate the question:  
Is  $\frac{z}{x - y} < \frac{2(x - y)}{y}$  ?

SUFFICIENT: We can manipulate  $zy < 2x^2 - 4xy + 2y^2$ :

$$\begin{aligned} zy &< 2x^2 - 4xy + 2y^2 \\ zy &< 2(x^2 - 2xy + y^2) \\ zy &< 2(x - y)(x - y) && \text{(dividing by } x - y \text{ is okay since } x - y > 0) \\ \frac{zy}{x - y} &< \frac{2(x - y)(x - y)}{x - y} \\ \frac{zy}{x - y} &< 2(x - y) && \text{(dividing by } y \text{ is okay since } y > 0) \\ \frac{z}{x - y} &< \frac{2(x - y)}{y} \end{aligned}$$

This manipulation shows us that the time it takes to fill tank 1 is definitely longer than the time it takes to fill tank 2.

INSUFFICIENT: We can express this statement algebraically as:  $1/2(z) > 2(x - y)$ . We cannot use this expression to provide us meaningful information about the question.

The correct answer is A.

12.

From the question stem, we know that Bill's rate is 1 well per  $x!$  hours and Carlos's rate is 1 well per  $y!$  hours.

Therefore, their combined rate is  $\frac{1}{x!} + \frac{1}{y!} = \frac{(x!) + (y!)}{x!y!}$ .

Since  $q$  is the amount of time it takes Bill and Carlos to dig a well together, we can

use the rate formula  $R = \frac{D}{T}$  to find  $q$  in terms of  $x$  and  $y$ . We can rearrange the

formula to isolate  $T$ :  $T = \frac{D}{R}$ .

Since  $q$  is the amount of time ( $T$ ) it takes the two men to dig 1 well together, the

$$T = \frac{1}{\frac{(x!) + (y!)}{x!y!}} = \frac{x!y!}{(x!) + (y!)}$$

"distance" ( $D$ ) here is 1 well. Therefore,  $T = \frac{x!y!}{(x!) + (y!)}$ . So we know

that  $q = \frac{x!y!}{(x!) + (y!)}$ .

The question then becomes: Is  $\frac{x!y!}{(x!) + (y!)}$  an integer?

Statement (1) tells us that  $x - y = 1$ . We now know that  $y = x - 1$ . We can substitute for  $y$  and simplify:

$$q = \frac{x!(x-1)!}{(x!) + (x-1)!} \rightarrow$$

$$q = \frac{x!(x-1)!}{x(x-1)! + (x-1)!} \rightarrow$$

$$q = \frac{x!(x-1)!}{(x-1)!(x+1)} \rightarrow$$

$$q = \frac{x! \cancel{(x-1)!}}{\cancel{(x-1)!}(x+1)} \rightarrow$$

$$q = \frac{x!}{x+1}$$

Is this sufficient to tell us whether  $q$  is an integer? Let's try some numbers. If  $x = 5$ ,

then  $\frac{5!}{6} = \frac{120}{6} = 20$ . But if  $x = 2$ , then  $\frac{2!}{3} = \frac{2}{3}$ . So in one case we get an integer, in another case we get a fraction. Statement (1) alone is insufficient to answer the question.

Statement (2) tells us that  $y$  is a nonprime even number. This means  $y$  can be any even number other than 2. We cannot tell from this whether  $q$  is an integer. For

example, if  $y = 4$  and  $x = 2$ , then  $\frac{2!4!}{(2!) + (4!)} = \frac{24}{13}$ . But if  $y = 4$  and  $x = 5$ , then  $\frac{5!4!}{(5!) + (4!)} = 20$ . So in one case we get a fraction, in another we get an integer. Statement (2) alone is insufficient to answer the question.

If we take the statements together, we know that  $q = \frac{x!}{x+1}$  and that  $y$  is an even number greater than 2 (because we are dealing with rates here, we do not have to worry about zero or negative evens).

Let's begin by analyzing the denominator of  $q$ , the expression  $x + 1$ . Since  $y$  is even and  $y = x - 1$ ,  $x$  must be odd. Therefore  $x + 1$  must be even. If  $x + 1$  is even, it must be the product of 2 and some integer (call it  $z$ ) that is less than  $x$ .

Now let's analyze the numerator of  $q$ , the expression  $x!$ . Since  $x$  is greater than  $y$ , it must be greater than 2. This means  $x!$  will have both 2 and  $z$  as factors (remember,  $z$  is less than  $x$ ).

Therefore both the 2 and  $z$  in  $x + 1$  (the denominator of  $q$ ) will cancel out with the 2 and  $z$  in  $x!$  (the numerator of  $q$ ), leaving only the product of integers.

For example, if  $x = 5$  and  $y = 4$ ,

$$\begin{aligned} \frac{5!4!}{(5!) + (4!)} &\rightarrow \\ \frac{5!4!}{5(4!) + 1(4!)} &\rightarrow \\ \frac{5!4!}{(4!)(5 + 1)} &\rightarrow \\ \frac{5! \cancel{4!}}{\cancel{(4!)}(6)} &\rightarrow \\ \frac{5!}{6} &\rightarrow \\ \frac{5 \cdot 4 \cdot \cancel{3} \cdot \cancel{2} \cdot 1}{\cancel{3} \cdot \cancel{2}} &\rightarrow \\ 5 \cdot 4 \cdot 1 = 20 & \end{aligned}$$

Therefore, if  $x - y = 1$  and if  $y$  is an even number greater than 2, then  $q$  will always be an integer.

The correct answer is C: BOTH statements TOGETHER are sufficient but NEITHER statement ALONE is sufficient.

# SPEED DISTANCE

1.

Let  $b$  be the number of hours Bob spends biking. Then  $(t - b)$  is the number of hours he spends walking. Let  $d$  be the distance in miles from his home to school. Since he had the flat tire halfway to school, he biked  $d/2$  miles and he walked  $d/2$  miles. Now we can set up the equations using the formula  $rate \times time = distance$ . Remember that we want to solve for  $d$ , the total distance from Bob's home to school.

$$1) \quad xb = d/2$$

$$2) \quad y(t - b) = d/2$$

Solving equation 1) for  $b$  gives us:

$$3) \quad b = d/2x \quad \text{Substituting this value of } b \text{ into equation 2 gives:}$$

$$4) \quad y(t - d/2x) = d/2 \quad \text{Multiply both sides by } 2x:$$

$$5) \quad 2xy(t - d/2x) = dx \quad \text{Distribute the } 2xy$$

$$6) \quad 2xyt - dy = dx \quad \text{Add } dy \text{ to both sides to collect the } d\text{'s on one side.}$$

$$7) \quad 2xyt = dx + dy \quad \text{Factor out the } d$$

$$8) \quad 2xyt = d(x + y) \quad \text{Divide both sides by } (x + y) \text{ to solve for } d$$

$$9) \quad 2xyt / (x + y) = d$$

The correct answer is C.

2.

We begin by figuring out Lexy's average speed. On her way from A to B, she travels 5 miles in one hour, so her speed is 5 miles per hour. On her way back from B to A, she travels the same 5 miles at 15 miles per hour. Her average speed for the

round trip is NOT simply the average of these two speeds. Rather, her average speed must be computed using the formula  $RT = D$ , where  $R$  is rate,  $T$  is time and  $D$  is distance. Her average speed for the **whole** trip is the **total** distance of her trip divided by the **total** time of her trip.

We already know that she spends 1 hour going from A to B. When she returns from B to A, Lexy travels 5 miles at a rate of 15 miles per hour, so our formula tells us that  $15T = 5$ , or  $T = 1/3$ . In other words, it only takes Lexy  $1/3$  of an hour, or 20 minutes, to return from B to A. Her total distance traveled for the round trip is  $5+5=10$  miles and her total time is  $1+1/3=4/3$  of an hour, or 80 minutes.

We have to give our final answer in minutes, so it makes sense to find Lexy's average rate in miles per minute, rather than miles per hour.  $10 \text{ miles} / 80 \text{ minutes} = 1/8 \text{ miles per minute}$ . This is Lexy's average rate.

We are told that Ben's rate is half of Lexy's, so he must be traveling at  $1/16$  miles per minute. He also travels a total of 10 miles, so  $(1/16)T = 10$ , or  $T = 160$ . Ben's round trip takes 160 minutes.

Alternatively, we could use a shortcut for the last part of this problem. We know that Ben's rate is half of Lexy's average rate. This means that, for the entire trip, Ben will take twice as long as Lexy to travel the same distance. Once we determine that Lexy will take 80 minutes to complete the round trip, we can double the figure to get Ben's time.  $80 \times 2 = 160$ .

The correct answer is D.

3.

Since the trains traveled the  $z$  miles in  $x$  and  $y$  hours, their speeds can be represented as  $z/x$  and  $z/y$  respectively.

We can again use an RTD chart to evaluate how far each train travels when they move toward each other starting at opposite ends. Instead of using another variable  $d$  here, let's express the two distances in terms of their respective rates and times.

	High-speed	Regular	Total
R	$z/x$	$z/y$	
T	$t$	$t$	
D	$zt/x$	$zt/y$	$z$

Since the two distances sum to the total when the two trains meet, we can set up the following equation:

$zt/x + zt/y = z$     divide both sides of the equation by  $z$   
 $t/x + t/y = 1$     multiply both sides of the equation by  $xy$   
 $ty + tx = xy$     factor out a  $t$  on the left side  
 $t(x + y) = xy$     divide both sides by  $x + y$

$$t = \frac{xy}{x + y}$$

To find how much further the high-speed train went in this time:

$$(rate_{high} \times time) - (rate_{reg} \times time)$$

$$(rate_{high} - rate_{reg}) \times time$$

$$\left( \frac{z}{x} - \frac{z}{y} \right) \times \frac{xy}{x + y}$$

$$\frac{zy - zx}{xy} \times \frac{xy}{x + y}$$

$$\frac{xy}{z(y - x)}$$

$$\frac{xy}{x + y}$$

The correct answer is A.

4.

To determine Bill's average rate of movement, first recall that Rate  $\times$  Time = Distance. We are given that the moving walkway is 300 feet long, so we need only determine the time elapsed during Bill's journey to determine his average rate.

There are two ways to find the time of Bill's journey. First, we can break down Bill's journey into two legs: walking and standing. While walking, Bill moves at 6 feet per second. Because the walkway moves at 3 feet per second, Bill's foot speed along the walkway is  $6 - 3 = 3$  feet per second. Therefore, he covers the 120 feet between himself and the bottleneck in  $(120 \text{ feet}) / (3 \text{ feet per second}) = 40$  seconds.

Now, how far along is Bill when he stops walking? While that 40 seconds elapsed, the crowd would have moved  $(40 \text{ seconds})(3 \text{ feet per second}) = 120$  feet. Because the crowd already had a 120 foot head start, Bill catches up to them at  $120 + 120 = 240$  feet. The final 60 feet are covered at the rate of the moving walkway, 3 feet per second, and therefore require  $(60 \text{ feet}) / (3 \text{ feet per second}) = 20$  seconds. The total journey requires  $40 + 20 = 60$  seconds, and Bill's rate of movement is  $(300 \text{ feet}) / (60 \text{ seconds}) = 5$  feet per second.

This problem may also be solved with a shortcut. Consider that Bill's journey will

end when the crowd reaches the end of the walkway (as long as he catches up with the crowd before the walkway ends). When he steps on the walkway, the crowd is 180 feet from the end. The walkway travels this distance in  $(180 \text{ feet}) / (3 \text{ feet per second}) = 60 \text{ seconds}$ , and Bill's average rate of movement is  $(300 \text{ feet}) / (60 \text{ seconds}) = 5 \text{ feet per second}$ .

The correct answer is E.

5.

It is easier to break this motion up into different segments. Let's first consider the 40 minutes up until John stops to fix his flat.

40 minutes is  $2/3$  of an hour.

In  $2/3$  of an hour, John traveled  $15 \times 2/3 = 10 \text{ miles}$  ( $rt = d$ )

In that same  $2/3$  of an hour, Jacob traveled  $12 \times 2/3 = 8 \text{ miles}$

John therefore had a two-mile lead when he stopped to fix his tire.

It took John 1 hour to fix his tire, during which time Jacob traveled 12 miles.

Since John began this 1-hour period 2 miles ahead, at the end of the period he is  $12 - 2 = 10 \text{ miles}$  behind Jacob.

The question now becomes "how long does it take John to bridge the 10-mile gap between him and Jacob, plus whatever additional distance Jacob has covered, while traveling at 15 miles per hour while Jacob is traveling at 12 miles per hour?" We can set up an  $rt = d$  chart to solve this.

	John	Jacob
$R$	15	12
$T$	$t$	$t$
$D$	$d + 10$	$d$

John's travel during this "catch-up period" can be represented as  $15t = d + 10$

Jacob's travel during this "catch-up period" can be represented as  $12t = d$

If we solve these two simultaneous equations, we get:

$$15t = 12t + 10$$

$$3t = 10$$

$$t = 3 \frac{1}{3} \text{ hours}$$

Another way to approach this question is to note that when John begins to ride again, Jacob is 10 miles ahead. So John must make up those first 10 miles plus whatever additional distance Jacob has covered while both are riding. Since Jacob's additional distance at any given moment is  $12t$  (measuring from the moment when John begins

riding again) we can represent the distance that John has to make up as  $12t + 10$ . We can also represent John's distance at any given moment as  $15t$ . Therefore,  $15t = 12t + 10$ , when John catches up to Jacob. We can solve this question as outlined above.

The correct answer is B.

## 6.

Use  $S$ ,  $R$  and  $B$  to represent the individual race times of Stephanie, Regine, and Brian respectively. The problem tells us that Stephanie and Regine's combined times exceed Brian's time by 2 hours. Therefore:

$$S + R = B + 2$$

In order to win the race, an individual's time must be less than one-third of the the combined times of all the runners. Thus, in order for Brian to win the race (meaning that Brian would have the lowest time), his time would need to be less than one-third of the combined times for all the runners. This can be expressed as follows:

$$B < \frac{1}{3}(S + R + B)$$

This inequality can be simplified as follows:

$$\begin{aligned} B &< \frac{1}{3}(S + R + B) \\ 3B &< S + R + B \\ 2B &< S + R \end{aligned}$$

Using the fact that  $S + R = B + 2$ , the inequality can be simplified even further:

$$\begin{aligned} 2B &< S + R \\ 2B &< B + 2 \\ B &< 2 \end{aligned}$$

This tells us that in order for Brian to win the race, his time must be less than 2 hours. However, this is impossible! We know that the fastest Brian runs is 8 miles per hour, which means that the shortest amount of time in which he could complete the 20 mile race is 2.5 hours.

This leaves us with Stephanie and Regine as possible winners. Since the problem gives us identical information about Stephanie and Regine, we cannot eliminate either one as a possible winner. Thus, the correct answer is D: Stephanie or Regine could have won the race

7.

If we want Brenda's distance to be twice as great as Alex's distance, we can set up the following equation:

$2(4T) = R(T - 1)$ , where  $4T$  is Alex's distance (rate  $\times$  time) and  $R(T - 1)$  is Brenda's distance (since Brenda has been traveling for one hour less).

If we simplify this equation to isolate the  $T$  (which represents Alex's total time), we get:

$$2(4T) = R(T - 1)$$

$$8T = RT - R$$

$$R = RT - 8T$$

$$R = T(R - 8)$$

$$R$$

$$\frac{\quad}{R - 8} = T$$

This is choice C.

8.

The key to solving this question lies in understanding the mathematical relationship that exists between the speed ( $s$ ), the circumference of the tires ( $c$ ) and the number of revolutions the tires make per second ( $r$ ). It makes sense that if you keep the speed of the car the same but increase the size of the tires, the number of revolutions that the new tires make per second should go down. What, however, is the exact relationship?

Sometimes the best way to come up with a formula expressing the relationship between different variables is to analyze the labels (or units) that are associated with those variables. Let's use the following units for the variables in this question (even though they are slightly different in the question):

$c$ : inches/revolution

$s$ : inches/sec

$r$ : revolutions/sec

The labels suggest: (rev/sec)  $\times$  (inches/rev) = (inches/sec), which means that  $rc = s$ .

When the speed is held constant, as it is in this question, the relationship  $rc = s$  becomes  $rc = k$ .  $r$  and  $c$  are inversely proportional to one another. When two variables are inversely proportional, it means that whatever factor you multiply one of the variables by, the other one changes by the inverse of that factor. For example if you keep the speed constant and you double the circumference of the tires, the rev/sec will be halved. In this way the product of  $c$  and  $r$  is kept constant.

In this question the circumferences of the tires are given in inches, the speed in miles per hour, and the rotational speed in revolutions per second. However, the

discrepancies here don't affect the fundamental mathematical relationship of inverse proportionality: if the speed is kept constant, the rev/sec of the tires will change in an inverse manner to the circumference of the tires.

Let's assign  $c_1$  = initial circumference;  $c_2$  = new circumference  
 $r_1$  = initial rev/sec ;  $r_2$  = new rev/sec

Since the speeds are held constant:

$$\begin{aligned}c_1 r_1 &= c_2 r_2 \\r_2 &= (c_1/c_2)r_1 \\r_2 &= (28/32)r_1 \\r_2 &= (7/8)r_1\end{aligned}$$

If the new rev/sec is  $7/8$  of the previous rev/sec, this represents a  $1/8$  or  $12.5\%$  decrease and the correct answer is (B). Relationships of inverse proportionality are important in any word problem on the GMAT involving a formula in the form of  $xy = z$  and in which  $z$  is held constant.

## 9.

We know that Team A wins the race by 7 seconds, which means that Runner 4 on Team B will cross the finish line 7 seconds after Runner 4 on Team A crosses the finish line. Thus, the question can be rephrased as follows: How far does Runner 4 on Team B run in 7 seconds? Since his lap time is 42 seconds, he covers  $7/42$ , or  $1/6$ , of the track in 7 seconds.

Therefore, we must determine the length of the track. The track is formed by a rectangle with two adjoining semicircles. The length of the track is equal to 2 times the length of the rectangle plus the circumference of the circle (the two semi-circles combined).

The diameter of the circle is: 180 meters – 120 meters = 60 meters. Thus, the radius of the circle is 30 meters and the circumference is  $2\pi r = 60\pi$  meters. Finally, the length of the track is:  $(2 \times 120 + 60\pi)$  meters =  $(240 + 60\pi)$  meters.

Remember, Runner 4 on Team B still has  $1/6$  of the lap to run when Runner 4 on Team A finishes the race. So, Team B loses the race by:  $(240 + 60\pi) / 6 = (40 + 10\pi)$  meters.

The correct answer is B.

10.

Distance = Rate  $\times$  Time, or  $D = RT$ .

(1) INSUFFICIENT: This statement tells us Harry's rate, 30 mph. This is not enough to calculate the distance from his home to his office, since we don't know anything about the time required for his commute.

$$D = RT = (30 \text{ mph}) (T)$$

$D$  cannot be calculated because  $T$  is unknown.

(2) INSUFFICIENT: If Harry had traveled twice as fast, he would have gotten to work in half the time, which according to this statement would have saved him 15 minutes. Therefore, his actual commute took 30 minutes. So we learn his commute time from this statement, but don't know anything about his actual speed.

$$D = RT = (R) (1/2 \text{ hour})$$

$D$  cannot be calculated because  $R$  is unknown.

(1) AND (2) SUFFICIENT: From statement (1) we learned that Harry's rate was 30 mph. From Statement (2) we learned that Harry's commute time was 30 minutes. Therefore, we can use the rate formula to determine the distance Harry traveled.

$$D = RT = (30 \text{ mph}) (1/2 \text{ hour}) = 15 \text{ miles}$$

The correct answer is C.

11.

The average speed is defined to be the total distance of the trip, divided by the total time of the trip. The question stem tells us the distance from New York to Boston is 250 miles, so we can rephrase the question as "How long did it take Bill to drive from New York to Boston?"

SUFFICIENT: Statement (1) tells us it took Bill 5 hours to drive from New York to Boston, answering the rephrased question. In fact, his average rate of speed equals  $250/5 = 50$  miles per hour.

INSUFFICIENT: Statement (2) tells us that at the midpoint of the trip Bill was going exactly 50 miles per hour, but we can't figure out how long the trip took from this information. Bill *may* have traveled at a constant rate of 50 mph throughout the whole trip, but he might also have been going faster or slower at different times.

The correct answer is A.

12. The question asks for the percent decrease in Edwin's travel time. To determine this, we need to be able to find the ratio between,  $T_1$  (the travel time if Edwin drives alone) and  $T_2$  (the travel time if Edwin and George drive together). Note that we do NOT need to determine specific values for  $T_1$  and  $T_2$ ; we only need to find the ratio between them.

Why? Percentage change is defined as follows: 
$$\frac{\text{Difference}}{\text{Original}} = \frac{T_1 - T_2}{T_1} = 1 - \frac{T_2}{T_1}$$

Ultimately, we can solve the percentage change equation above by simply

determining the value of  $\frac{T_2}{T_1}$ .

Using the formula Rate  $\times$  Time = Distance, we can write equations for each of the 2 possible trips.

$T_1$  = Travel time if Edwin drives alone

$T_2$  = Travel time if Edwin and George drive together

E = Edwin's Rate

G = George's Rate

D = Distance of the trip

If Edwin travels alone:  $ET_1 = D$

If Edwin and George travel together:  $.5(E + G)T_2 = D$

(Since Edwin and George split the driving equally, the rate for the trip is equal to the average of Edwin and George's individual rates).

Since both trips cover the same distance (D), we can combine the 2 equations as follows:

$$ET_1 = .5(E + G)T_2$$

Then, we can isolate the ratio of the times ( $T_2/T_1$ ) as follows:

$$\frac{E}{.5(E + G)} = \frac{T_2}{T_1}$$

Now we look at the statements to see if they can help us to solve for the ratio of the times.

Statement (1) gives us a value for D, the distance, which does not help us since D is not a variable in the ratio equation above.

Statement (2) tells us that George's rate is 1.5 times Edwin's rate. Thus,  $G = 1.5E$ . We can substitute this information into the ratio equation above:

$$\begin{aligned} \frac{E}{.5(E+G)} = \frac{T_2}{T_1} &\rightarrow \frac{E}{.5(E+1.5E)} = \frac{T_2}{T_1} \rightarrow \frac{E}{.5E+.75E} = \frac{T_2}{T_1} \\ &\rightarrow \frac{E}{1.25E} = \frac{T_2}{T_1} \rightarrow \frac{1}{1.25} = \frac{T_2}{T_1} \rightarrow .8 = \frac{T_2}{T_1} \end{aligned}$$

Thus, using this ratio we can see that Edwin's travel time for the trip will be reduced as follows:

$$1 - \frac{T_2}{T_1} = 1 - .8 = .2 \rightarrow 20\%$$

Statement (2) alone is sufficient to answer the question. The correct answer is B.

13. We are asked to find the time that it takes Train B to travel the entire distance between the two towns.

**SUFFICIENT:** This tells us that B started traveling 1 hour after Train A started traveling. From the question we know that Train A had been traveling for 2 hours when the trains passed each other. Thus, train B, which started 1 hour later, must have been traveling for  $2 - 1 = 1$  hour when the trains passed each other.

Let's call the point at which the two trains pass each other Point P. Train A travels from Town H to Point P in 2 hours, while Train B travels from Town G to Point P in 1 hour. Adding up these distances and times, we have it that the two trains covered the entire distance between the towns in 3 (i.e.  $2 + 1$ ) hours of combined travel time. Since both trains travel at the same rate, it will take 3 hours for either train to cover the entire distance alone. Thus, from Statement (1) we know that it will take Train B 3 hours to travel between Town G and Town H.

**INSUFFICIENT:** This provides the rate for Train B. Since both trains travel at the same rate, this is also the rate for Train A. However, we have no information about when Train B started traveling (relative to when Train A started traveling) and we have no information about the distance between Town G and Town H. Thus, we cannot calculate any information about time.

The correct answer is A.

14.

Since  $AB = BC$ , triangle ABC is a 45-45-90 triangle. Such triangles have fixed side ratios as follows:

$$AB : BC : AC \rightarrow 1 : 1 : \sqrt{2}$$

Thus, we can call Greg's distance (AB)  $x$ , while Brian's distance (AC) is

$\sqrt{2}x$  or  $\sim 1.4x$ . Brian has a greater distance to travel.

Let's first analyze Statement (1) alone: Greg's average speed is  $\frac{2}{3}$  that of Brian's.

This indicates that Brian is traveling 1.5 times faster than Greg. If Greg's rate is  $r$ , then Brian's rate is  $1.5r$ . However, recall that Brian also has a greater distance to travel.

To determine who will arrive first, we use the distance formula:

**Rate x Time = Distance.** Whoever has a shorter **TIME** will arrive first.

<p>Greg's time  <math display="block">= \frac{\text{Distance}}{\text{Rate}} = \frac{x}{r}</math></p>	<p>Brian's time =  <math display="block">\frac{\text{Distance}}{\text{Rate}} = \frac{1.4x}{1.5r} = .93 \left( \frac{x}{r} \right)</math></p>
--	--

Since Brian is traveling for less time, he will arrive first. Statement (1) alone is sufficient.

**Let's now analyze Statement (2) alone: Brian's average speed is 20 miles per hour greater than Greg's.**

This gives us no information about the ratio of Brian's average speed to Greg's average speed. Thus, although we know that Brian's distance is approximately 1.4 times Greg's speed, we do not know the ratio of their speeds, so we can not determine who will arrive first.

For example, if Brian travels at 25 mph, Greg travels at 5 mph. In this case Brian arrives first. However, if Brian travels at 100 mph, Greg travels at 80 mph. In this case Greg arrives first.

Therefore, Statement (2) alone is not sufficient.

Since statement (1) alone is sufficient, but statement (2) alone is not sufficient, the correct answer is A.

**15.**

1). Insufficient, no idea about the car's speed for the next 200 kms

2)  $(\text{Actual speed} + 20) * (\text{actual time} - 1 \text{ hour}) = 400 \text{ kms} = \text{actual speed} * \text{actual time}$

Can solve for actual time

Answer is B

**16.**

1).  $x/50 + (530-x)/60 = 10$ , so,  $x$  can be solve out and  $x/50$  will be the answer

2). The time cost on two distances could be 5h, 1h; 6h, 2h;... insufficient.

Answer is A

# SI / CI / Population Growth

1.

If we decide to find a constant multiple by the hour, then we can say that the population was multiplied by a certain number three times from 1 p.m. to 4 p.m.: once from 1 to 2 p.m., again from 2 to 3 p.m., and finally from 3 to 4 p.m.

Let's call the constant multiple  $x$ .

$$2,000(x)(x)(x) = 250,000$$

$$2,000(x^3) = 250,000$$

$$x^3 = 250,000/2,000 = 125$$

$$x = 5$$

Therefore, the population gets five times bigger each hour.

At 3 p.m., there were  $2,000(5)(5) = 50,000$  bacteria.

The correct answer is A.

2.

A population problem on the GMAT is best solved with a population chart that illustrates the swarm population at each unit of time. An example of a population chart is shown below:

Time	Population
4 hours ago	1,000
2 hours ago	2,000
NOW	4,000
in 2 hours	8,000
in 4 hours	16,000
in 6 hours	32,000
in 8 hours	64,000
in 10 hours	128,000
in 12 hours	256,000

As can be seen from the chart, in 12 hours the swarm population will be equal to 256,000 locusts. Thus, we can infer that the number of locusts will exceed 250,000 in slightly less than 12 hours. Since we are asked for an approximate value, 12 hours provides a sufficiently close approximation and is therefore the correct answer.

The correct answer is D

3.

We need to consider the formula for compound interest for this problem:  $F = P(1 + r)^x$ , where  $F$  is the final value of the investment,  $P$  is the principal,  $r$  is the interest rate per compounding period as a decimal, and  $x$  is the number of compounding periods (NOTE: sometimes the formula is written in terms of the annual interest rate, the number of compounding periods per year and the number of years). Let's start by manipulating the given expression for  $r$ :

$$\begin{aligned}r &= 100 \left( \sqrt{\frac{v+q}{p}} - 1 \right) \rightarrow \frac{r}{100} = \sqrt{\frac{v+q}{p}} - 1 \rightarrow 1 + \frac{r}{100} = \sqrt{\frac{v+q}{p}} \rightarrow \\ \left( 1 + \frac{r}{100} \right)^2 &= \left( \sqrt{\frac{v+q}{p}} \right)^2 \rightarrow \left( 1 + \frac{r}{100} \right)^2 = \frac{v+q}{p} \rightarrow p \left( 1 + \frac{r}{100} \right)^2 = v+q \rightarrow \\ v &= p \left( 1 + \frac{r}{100} \right)^2 - q\end{aligned}$$

Let's compare this simplified equation to the compound interest formula. Notice that  $r$  in this simplified equation (and in the question) is not the same as the  $r$  in the compound interest formula. In the formula, the  $r$  is already expressed as a decimal equivalent of a percent, in the question the interest is  $r$  percent. The simplified equation, however, deals with this discrepancy by dividing  $r$  by 100.

In our simplified equation, the cost of the share of stock ( $p$ ), corresponds to the principal ( $P$ ) in the formula, and the final share price ( $v$ ) corresponds to the final value ( $F$ ) in the formula. Notice also that the exponent 2 corresponds to the  $x$  in the formula, which is the number of compounding periods. By comparing the simplified equation to the compound interest formula, we see that the equation tells us that the share rose at the daily interest rate of  $p$  percent for TWO days. Then the share lost a value of  $q$  dollars on the third day, i.e. the " $-q$ " portion of the expression. If the investor bought the share on Monday, she sold it three days later on Thursday. The correct answer is B.

4.

Compound interest is computed using the following formula:

$$F = P ( 1 + r/n )^{nt}, \text{ where}$$

$F$  = Final value

$P$  = Principal

$r$  = annual interest rate

$n$  = number of compounding periods per year

$t$  = number of years

From the question, we can deduce the following information about the growth during this period:

At the end of the  $x$  years, the final value,  $F$ , will be equal to 16 times the principal (the money is growing by a factor of 16).

Therefore,  $F = 16P$ .

$r = .08$  (8% annual interest rate)

$n = 4$  (compounded quarterly)

$t = x$  (the question is asking us to express the time in terms of  $x$  number of years)

We can write the equation

$$16P = P(1 + .08/4)^{4x}$$

$$16 = (1.02)^{4x}$$

Now we can take the fourth root of both sides of the equation. (i.e. the equivalent of taking the square root twice) We will only consider the positive root because a negative 2 doesn't make sense here.

$$16^{1/4} = [(1.02)^{4x}]^{1/4}$$

$$2 = (1.02)^x$$

The correct answer is B.

5.

The formula for calculating compound interest is  $A = P(1 + r/n)^{nt}$  where the variables represent the following:

$A$  = amount of money accumulated after  $t$  years (principal + interest)

$P$  = principal investment

$r$  = interest rate (annual)

$n$  = number of times per year interest is compounded

$t$  = number of years

In this case,  $x$  represents the unknown principal,  $r = 8\%$ ,  $n = 4$  since the compounding is done quarterly, and  $t = .5$  since the time frame in question is half a year (6 months).

You can solve this problem without using compound interest. 8% interest over half a year, however that interest is compounded, is approximately 4% interest. So, to compute the principal, it's actually a very simple calculation:

$$100 = .04x$$

$$2500 = x$$

The correct answer is D.

6.

To solve a population growth question, we can use a population chart to track the growth. The annual growth rate in this question is unknown, so we will represent it as  $x$ . For example, if the population doubles each year,  $x = 2$ ; if it grows by 50% each year,  $x = 1.5$ . Each year the population is multiplied by this factor of  $x$ .

Time	Population
Now	500
In 1 year	$500x$
In 2 years	$500x^2$
:	:
In $n$ years	$500x^n$

The question is asking us to find the minimum number of years it will take for the herd to double in number. In other words, we need to find the minimum value of  $n$  that would yield a population of 1000 or more.

We can represent this as an inequality:

$$500x^n > 1000$$

$$x^n > 2$$

In other words, we need to find what integer value of  $n$  would cause  $x^n$  to be greater than 2. To solve this, we need to know the value of  $x$ . Therefore, we can rephrase this question as: "What is  $x$ , the annual growth factor of the herd?"

(1) INSUFFICIENT: This tells us that in ten years the following inequality will hold:

$$500x^{10} > 5000$$

$$x^{10} > 10$$

There are an infinite number of growth factors,  $x$ , that satisfy this inequality.

For example,  $x = 1.5$  and  $x = 2$  both satisfy this inequality.

If  $x = 2$ , the herd of antelope doubles after one year.

If  $x = 1.5$ , the herd of antelope will be more than double after two years  $500(1.5)(1.5) = 500(2.25)$ .

(2) SUFFICIENT: This will allow us to find the growth factor of the herd. We can represent the growth factor from the statement as  $y$ . (NOTE  $y$  does not necessarily equal  $2x$  because  $x$  is a growth factor. For example, if the herd actually grows at a rate of 10% each year,  $x = 1.1$ , but  $y = 1.2$ , i.e. 20%)

Time	Population
Now	500
In 1 year	$500y$
In 2 years	$500y^2$

According to the statement,  $500y^2 = 980$

$$y^2 = 980/500$$

$$y^2 = 49/25$$

$y = 7/5$  OR  $1.4$  ( $y$  can't be negative because we know the herd is growing)

This means that the hypothetical double rate from the statement represents an annual growth rate of 40%.

The actual growth rate is therefore 20%, so  $x = 1.2$ .

The correct answer is B.

7.

In order to answer this question, we need to know the formula for compound interest:

$$FV = P \left( 1 + \frac{r}{100n} \right)^{nt}$$

$FV$  is the future value.

$P$  is the present value (or the principle).

$r$  is the rate of interest.

$n$  is the number of compounding periods per year.

$t$  is the number of years.

Since Grace deposited  $x$  dollars at a rate of  $z$  percent, compounded annually:

$$\text{Grace's } FV = x \left( 1 + \frac{z}{100} \right)^{(1)(t)}$$

And since Georgia deposited  $y$  dollars at a rate of  $z$  percent, compounded quarterly (four times per year):

$$\text{Georgia's } FV = y \left( 1 + \frac{z}{(4)(100)} \right)^{(4)(t)}$$

So the question becomes:

$$\text{Is } x \left( 1 + \frac{z}{100} \right)^{(1)(t)} > y \left( 1 + \frac{z}{(4)(100)} \right)^{(4)(t)} \quad ?$$

Statement 1 tells us that  $z = 4$ . This tells us nothing about  $x$  or  $y$ . Insufficient.

Statement 2 tells us that  $100y = zx$ . Therefore, it must be true that  $y = zx/100$ . We can use this information to simplify the question:

$$\begin{aligned} x \left( 1 + \frac{z}{100} \right)^{(1)(t)} &> y \left( 1 + \frac{z}{(4)(100)} \right)^{(4)(t)} \rightarrow \\ x \left( 1 + \frac{z}{100} \right) &> \frac{zx}{100} \left( 1 + \frac{z}{400} \right)^4 \rightarrow \\ \left( \frac{100}{x} \right) (x) \left( 1 + \frac{z}{100} \right) &> \left( \frac{100}{x} \right) \left( \frac{zx}{100} \right) \left( 1 + \frac{z}{400} \right)^4 \rightarrow \\ 100 \left( 1 + \frac{z}{100} \right) &> z \left( 1 + \frac{z}{400} \right)^4 \rightarrow \\ 100 + z &> z \left( 1 + \frac{z}{400} \right)^4 \end{aligned}$$

---

The question is now:

$$\text{Is } 100 + z > z \left( 1 + \frac{z}{400} \right)^4 ?$$

We know from the question stem that  $z$  has a maximum value of 50. If we substitute that maximum value for  $z$ , we get:

$$100 + 50 > 50 \left( 1 + \frac{50}{400} \right)^4 \rightarrow$$

$$150 > 50 (1 + .125)^4 \rightarrow$$

$$3 > (1.125)^4$$

So the question is now:

$$\text{Is } 3 > (1.125)^4 ?$$

Using estimation, we can see that this inequality is true. Since the maximum value of  $z$  makes this inequality true, all smaller values of  $z$  will do so as well. Therefore, we can answer "yes" to the rephrased question. Sufficient.

The correct answer is B: Statement 2 alone is sufficient, but statement 1 alone is not.

## 8.

Let's say:

$I$  = the original amount of bacteria

$F$  = the final amount of bacteria

$t$  = the time bacteria grows

If the bacteria increase by a factor of  $x$  every  $y$  minutes, we can represent the growth of the bacteria with the equation:

$$F = I(x)^{t/y}$$

To understand why, let's assign some values to  $I$ ,  $x$  and  $y$ :

$I =$	100
$x =$	2
$y =$	3

If the bacteria start off 100 in number and they double every 3 minutes, after 3 minutes there will be 100(2) bacteria. Let's construct a table to track the growth of the bacteria:

$t$ (time)	$F$ (final count)
3	$100(2) = 100(2)^1$
6	$100(2)(2) = 100(2)^2$
9	$100(2)(2)(2) = 100(2)^3$
12	$100(2)(2)(2)(2) = 100(2)^4$

We can generalize the  $F$  values in the table as  $100(2)^n$ .

The 100 represents the initial count,  $I$ .

The 2 represents the factor of growth (in this problem  $x$ ).

The  $n$  represents the number of growth periods. The number of growth periods is found by dividing the time,  $t$ , by the amount of time it takes to complete a period,  $y$ .

From this example, we can extrapolate the general formula for exponential growth:  $F = I(x)^{t/y}$

This question asks us how long it will take for the bacteria to grow to 10,000 times their original amount.

The bacteria will have grown to 10,000 times their original amount when  $F = 10,000I$ .

If we plug this into the general formula for exponential growth, we get:  $10,000I = I(x)^{t/y}$  or  $10,000 = (x)^{t/y}$ .

The question is asking us to solve for  $t$ .

(1) SUFFICIENT: This statement tells us that  $x^{1/y} = 10$ . If we plug this value into the equation we can solve for  $t$ .

$$10,000 = (x)^{t/y}$$

$$10,000 = [(x)^{1/y}]^t$$

$$10,000 = (10)^t$$

$$t = 4$$

(2) SUFFICIENT: The bacteria grow one hundredfold in 2 minutes, that is to say they grow by a factor of  $10^2$ . Since exponential growth is characterized by a constant factor of growth (i.e. by  $x$  every  $y$  minutes), for the bacteria to grow 10,000 fold (i.e. a factor of  $10^4$ ), they will need to grow another 2 minutes, for a total of four minutes ( $10^2 \times 10^2 = 10^4$ ).

The correct answer is D, EACH statement ALONE is sufficient to answer the question.

# RATIOS

1.

First, let us rephrase the question. Since we need to find the fraction that is at least twice greater than  $11/50$ , we are looking for a fraction that is equal to or greater than  $22/50$ . Further, to facilitate our analysis, note that we can come up with an easy benchmark value for this fraction by doubling both the numerator and the denominator and thus expressing it as a percent:  $22/50 = 44/100 = 44\%$ . Thus, we can rephrase the question: "Which of the following is greater than or equal to 44%?"

Now, let's analyze each of the fractions in the answer choices using benchmark values:

$2/5$ : This fraction can be represented as 40%, which is less than 44%.

$11/34$ : This value is slightly less than  $11/33$  or  $1/3$ . Therefore, it is smaller than 44%.

$43/99$ : Note that the fraction  $43/99$  is smaller than  $44/100$ , since fractions get smaller if the same number (in this case integer 1) is subtracted from both the numerator and the denominator.

$8/21$ : We know that  $8/21$  is a little less than  $8/20$  or  $2/5$ . Thus,  $8/21$  is less than 44%.

$9/20$ : Finally, note that by multiplying the numerator and the denominator by 5, we can represent this fraction as  $45/100$ , thus concluding that this fraction is greater than 44%.

The correct answer is E.

2.

Let's denote the number of juniors and seniors at the beginning of the year as  $j$  and  $s$ , respectively. At the beginning of the year, the ratio of juniors to seniors was 3 to 4:

$$j/s = 3/4. \text{ Therefore, } j = 0.75s$$

At the end of the year, there were  $(j - 10)$  juniors and  $(s - 20)$  seniors.

Additionally, we know that the ratio of juniors to seniors at the end of the year was 4 to 5. Therefore, we can create the following equation:

$$\frac{j - 10}{s - 20} = \frac{4}{5}$$

Let's solve this equation by substituting  $j = 0.75s$ :

$$\begin{aligned} \frac{j - 10}{s - 20} &= 0.8 \\ (j - 10) &= 0.8(s - 20) \\ (0.75s - 10) &= 0.8s - 16 \\ 0.8s - 0.75s &= 16 - 10 \\ 0.05s &= 6 \\ s &= 120 \end{aligned}$$

Thus, there were 120 seniors at the beginning of the year.

The correct answer is E.

3.

For a fraction question that makes no reference to specific values, it is best to assign a smart number as the "whole value" in the problem. In this case we'll use 30 since that is the least common denominator of all the fractions mentioned in the problem.

If there are 30 students in the class,  $3/5$  or 18, left for the field trip. This means that 12 students were left behind.

$1/3$  of the 12 students who stayed behind, or 4 students, didn't want to go on the field trip.

This means that 8 of the 12 who stayed behind *did* want to go on the field trip.

When the second vehicle was located, half of these 8 students or 4, were able to join the other 18 who had left already.

That means that 22 of the 30 students ended up going on the trip.  $22/30$  reduces to  $11/15$  so the correct answer is C.

4.

The ratio of boys to girls in Class A is 3 to 4. We can represent this as an equation:  $b/g = 3/4$ . We can isolate the boys:

$$\begin{aligned} 4b &= 3g \\ b &= (3/4)g \end{aligned}$$

Let's call the number of boys in Class B  $x$ , and the number of girls in Class B  $y$ . We know that the number of boys in Class B is one less than the number of boys in Class A. Therefore,  $x = b - 1$ . We also know that the number of girls in Class B is

two less than the number of girls in Class A. Therefore,  $y = g - 2$ . We can substitute these in the combined class equation:

The combined class has a boy/girl ratio of 17 to 22:  $(b + x)/(g + y) = 17/22$ .

$$(b + b - 1)/(g + g - 2) = 17/22$$

$$(2b - 1)/(2g - 2) = 17/22$$

Cross-multiplying yields:

$$44b - 22 = 34g - 34$$

Since we know that  $b = (3/4)g$ , we can replace the  $b$ :

$$44(3/4)g - 22 = 34g - 34$$

$$33g - 22 = 34g - 34$$

$$12 = g$$

Alternatively, because the numbers in the ratios and the answer choices are so low, we can try some real numbers. The ratio of boys to girls in Class A is 3:4, so here are some possible numbers of boys and girls in Class A:

B:G

3:4

6:8

9:12

The ratio of boys to girls in Class B is 4:5, so here are some possible numbers of boys and girls in Class A:

B:G

4:5

8:10

12:15

We were told that there is one more boy in Class A than Class B, and two more girls in Class A than Class B. If we look at our possibilities above, we see that this information matches the case when we have 9 boys and 12 girls in Class A and 8 boys and 10 girls in Class B. Further, we see we would have  $9 + 8 = 17$  boys and  $12 + 10 = 22$  girls in a combined class, so we have the correct 17:22 ratio for a combined class. We know now there are 12 girls in Class A.

The correct answer is E.

5.

We can solve this problem by choosing a smart number to represent the size of the back lawn. In this case, we want to choose a number that is a multiple of 2 and 3 (the denominators of the fractions given in the problem). This way, it will be easy to split the lawn into halves and thirds. Let's assume the size of the back lawn is 6.

$$(\text{size back lawn}) = 6 \text{ units}$$

$$(\text{size front lawn}) = (1/3)(\text{size back lawn}) = 2 \text{ units}$$

$$(\text{size total lawn}) = (\text{size back lawn}) + (\text{size front lawn}) = 8 \text{ units}$$

Now we can use these numbers to calculate how much of each lawn has been mowed:

Front lawn:  $(1/2)(2) = 1$  unit

Back lawn:  $(2/3)(6) = 4$  unit

So, in total, 5 units of lawn have been mowed. This represents  $5/8$  of the total, meaning  $3/8$  of the lawn is left unmowed.

Alternatively, this problem can be solved using an algebraic approach. Let's assume the size of the front lawn is  $x$  and size of the back lawn is  $y$ . So, John has mowed  $(1/2)x$  and  $(2/3)y$ , for a total of  $(1/2)x + (2/3)y$ . We also know that  $x = (1/3)y$ . Substituting for  $x$  gives:

$$\begin{aligned} &(1/2)x + (2/3)y \\ &(1/2)(1/3)y + (2/3)y \\ &(1/6)y + (2/3)y \\ &(5/6)y = \text{lawn mowed} \end{aligned}$$

The total lawn is the sum of the front and back,  $x + y$ . Again, substituting for  $x$  gives  $(1/3)y + y = (4/3)y$ . So, the fraction of the total lawn mowed is:

$$\frac{\text{lawn mowed}}{\text{total lawn}}$$

$$\frac{(5/6)y}{(4/3)y} = \frac{(5/6)}{(4/3)} = (5/6) \times (3/4) = 15/24 = 5/8. \text{ This leaves } 3/8 \text{ unmowed.}$$

The correct answer is C.

6.

We know that the student to teacher ratio at the school is 16 to 1, and the total number of people is 510. Therefore:

$$\text{Number of students} = (16/17)(510) = 480$$

$$\text{Number of teachers} = (1/17)(510) = 30$$

Kindergarten students make up  $1/5$  of the student population, so:

$$\text{Number of kindergarten students} = (1/5)(480) = 96$$

Fifth and sixth graders account for  $1/3$  of the remainder (after kindergarten

students are subtracted from the total), therefore:

$$\text{Number of 5th and 6th grade students} = (1/3)(480 - 96) = (1/3)(384) = 128$$

Students in first and second grades account for 1/4 of all the students, so:

$$\text{Number of 1st and 2nd grade students} = (1/4)(480) = 120$$

So far, we have accounted for every grade but the 3rd and 4th grades, so they must consist of the students left over:

$$\text{Number of 3rd and 4th grade students} = \text{Total students} - \text{students in other grades}$$

$$\text{Number of 3rd and 4th grade students} = 480 - 96 - 128 - 120 = 136$$

If there are an equal number of students in the third and fourth grades, then:

$$\text{Number of 3rd grade students} = 136/2 = 68$$

The number of students in third grade is 68, which is fewer than 96, the number of students in kindergarten. The number of students in 3rd grade is thus  $96 - 68 = 28$  fewer than the number of kindergarten students.

The correct answer is C.

7.

For a fraction word problem with no actual values for the total, it is best to plug numbers to solve.

Since  $3/5$  of the total cups sold were small and  $2/5$  were large, we can arbitrarily assign 5 as the number of cups sold.

$$\text{Total cups sold} = 5$$

$$\text{Small cups sold} = 3$$

$$\text{Large cups sold} = 2$$

Since the large cups were sold at  $7/6$  as much per cup as the small cups, we know:

$$Price_{large} = (7/6)Price_{small}$$

Let's assign a price of 6 cents per cup to the small cup.

$$\text{Price of small cup} = 6 \text{ cents}$$

$$\text{Price of large cup} = 7 \text{ cents}$$

Now we can calculate revenue per cup type:

$$\text{Large cup sales} = \text{quantity} \times \text{cost} = 2 \times 7 = 14 \text{ cents}$$

$$\text{Small cup sales} = \text{quantity} \times \text{cost} = 3 \times 6 = 18 \text{ cents}$$

$$\text{Total sales} = 32 \text{ cents}$$

$$\text{The fraction of total revenue from large cup sales} = 14/32 = 7/16.$$

The correct answer is A.

8.

Boys =  $\frac{2n}{5}$ , girls =  $\frac{3n}{5}$

$$\text{Girls studying Spanish} = \frac{3n}{5} \times \frac{1}{3} = \frac{n}{5}$$

$$\text{Girls not studying Spanish} = \frac{3n}{5} - \frac{n}{5} = \frac{2n}{5}$$

$$\text{Girls studying French} = \frac{2n}{5} \times \frac{5}{6} = \frac{2n}{6} = \frac{n}{3}$$

Girls studying German = (all girls) – (girls studying Spanish) – (girls studying French)

$$\text{Girls studying German} = \frac{3n}{5} - \frac{n}{5} - \frac{n}{3}$$

$$\text{Girls studying German} = \frac{2n}{5} - \frac{n}{3} = \frac{6n}{15} - \frac{5n}{15} = \frac{n}{15}$$

The correct answer is E.

9.

Since the problem deals with fractions, it would be best to pick a smart number to represent the number of ball players. The question involves thirds, so the number we pick should be divisible by 3. Let's say that we have 9 right-handed players and 9 left-handed players (remember, the question states that there are equal numbers of righties and lefties).

Two-thirds of the players are absent from practice, so that is  $(2/3)(18) = 12$ . This leaves 6 players at practice. Of these 6 players, one-third were left-handed. This yields  $(1/3)(6) = 2$  left-handed players at practice and  $9 - 2 = 7$  left-handed players NOT at practice. Since 2 of the 6 players at practice are lefties,  $6 - 2 = 4$  players at practice must be righties, leaving  $9 - 4 = 5$  righties NOT at practice.

The question asks us for the ratio of the number of righties not at practice to the number of lefties not at practice. This must be  $5 : 7$  or  $5/7$ .

The correct answer is C.

10.

We are told that bag B contains red and white marbles in the ration 1:4. This implies that  $W_B$ , the number of white marbles in bag B, must be a multiple of 4.

What can we say about  $W_A$ , the number of white marbles in bag A? We are given *two* ratios involving the white marbles in bag A. The fact that the ratio of red to white marbles in bag A is 1:3 implies that  $W_A$  must be a multiple of 3. The fact that the ratio of white to blue marbles in bag A is 2:3 implies that  $W_A$  must be a multiple of 2. Since  $W_A$  is both a multiple of 2 *and* a multiple of 3, it must be a multiple of 6.

We are told that  $W_A + W_B = 30$ . We have already figured out that  $W_A$  must be a multiple of 6 and that  $W_B$  must be a multiple of 4. So all we need to do now is to test each candidate value of  $W_A$  (i.e. 6, 12, 18, and 24) to see whether, when plugged into  $W_A + W_B = 30$ , it yields a value for  $W_B$  that is a multiple of 4. It turns out that  $W_A = 6$  and  $W_A = 18$  are the only values that meet this criterion.

Recall that the ratio of red to white marbles in bag A is 1:3. If there are 6 white marbles in bag A, there are 2 red marbles. If there are 18 white marbles in bag A, there are 6 red marbles. Thus, the number of red marbles in bag A is either 2 or 6.

Only one answer choice matches either of these numbers.

The correct answer is D.

11.

Initially the ratio of B: C: E can be written as  $8x: 5x: 3x$ . (Recall that ratios always employ a common multiplier to calculate the actual numbers.)

After removing 4 pounds of clothing, the ratio of books to clothes is doubled. To double a ratio, we double just the first number; in this case, doubling 8 to 5 yields a new ratio of 16 to 5. This can be expressed as follows:

$$\frac{\text{books}}{\text{clothing}} = \frac{8x}{5x - 4} = \frac{16}{5} \quad \text{Cross multiply to solve for } x:$$

$$40x = 80x - 64$$

$$40x = 64$$

$$x = 8/5$$

The question asks for the approximate weight of the electronics in the suitcase. Since there are  $3x$  pounds of electronics there are  $3 \times (8/5) = 24/5$  or approximately 5 pounds of electronics in the suitcase.

The correct answer is C.

12.

The question asks us to find the ratio of gross revenue of computers to printers, given that the price of a computer is five times the price of a printer. We will prove that the statements are insufficient either singly or together by finding two examples that satisfy all the criteria but give two different ratios for the gross revenue of computers to printers.

(1) INSUFFICIENT: Statement (1) says that the ratio of computers to printers sold in the first half of 2003 was in the ratio of 3 to 2, so let's assume they sold 3 computers and 2 printers. Using an example price of \$5 and \$1 indicates that the computer gross was \$15 and the printer gross was \$2.

During the second half of 2003, the ratio of computers to printers sold was 2 to 1. For example, they may have sold 2 computers and 1 printer grossing \$10 and \$1 respectively. Adding in the first half revenue, we can calculate that they would have grossed \$25 and \$3 respectively for the full year.

Alternatively for the second half of 2003 they may have sold 4 computers and 2 printers, which is still in the ratio of 2 to 1. In this case they would have grossed \$20 and \$2 respectively. Now adding in the first half revenue indicates they would have grossed \$35 and \$4 respectively for the full year, which is a different ratio. Therefore statement (1) is insufficient to give us a definitive answer.

(2) INSUFFICIENT: Statement (2) tells us that a computer costs \$1,000, but it tells us nothing about the ratio or numbers of computers or printers sold.

(1) and (2) INSUFFICIENT: Statement (2) fixes the price of a computer at \$1000, but the counterexample given in the explanation of statement (1) still holds, so statements (1) and (2) together are still insufficient.

The correct answer is E.

13.

Let  $x$  represent the amount of water in Pool X, and  $y$  represent the amount of water in Pool Y. If we let  $z$  represent the proportion of Pool Y's current volume that needs to be transferred to Pool X, we can set up the following equation and solve for  $z$ :

$$\begin{aligned}
 & \text{(water currently in Pool X) + (water transferred) = (water currently in Pool Y) -} \\
 & \text{(water transferred)} \\
 & x + zy = y - zy \\
 & x + 2zy = y \\
 & 2zy = y - x \\
 & \quad \quad \quad \frac{y}{2y} \quad \quad \quad \frac{x}{2y} \\
 z = & \frac{\quad}{2y} - \frac{\quad}{2y} \\
 & \frac{1}{2} \quad \quad \quad \left( 1 - \frac{x}{y} \right) \\
 z = & \frac{\quad}{2} \quad \quad \quad \left( 1 - \frac{x}{y} \right)
 \end{aligned}$$

So, the value of  $z$  depends only on the ratio of the water currently in Pool X to the water currently in

Pool Y, or:  $\frac{x}{y}$ . The rephrased question is: "What is  $\frac{x}{y}$ ?"

Remember that  $x$  and  $y$  do NOT represent the capacities of either pool, but rather the ACTUAL AMOUNTS of water in each pool.

(1) SUFFICIENT: if we let  $X$  represent the capacity of Pool X, then the amount of water in Pool X is  $(2/7)X$ . So,  $x = (2/7)X$ . We can calculate the total amount of water in Pool Y, or  $y$ , as follows:  $y = (6/7)X - (2/7)X = (4/7)X$ . We can see that Pool Y has twice as much water

as Pool X, or  $2x = y$ , or  $\frac{x}{y} = 1/2$ .

(2) INSUFFICIENT: This gives no information about the amount of water in Pool Y.

The correct answer is A.

14.

We can rewrite the information in the question as an equation representing the T, the total dollar value of the sale:

$$L + M + S = T$$

L = the dollar amount received by the partner with the largest share

M = the dollar amount received by the partner with the middle (second largest) share

S = the dollar amount received by the partner with the smallest share

We are also told in the question that  $L = (5/8)T$ . Thus we can rewrite the equation as follows:

$$(5/8)T + M + S = T.$$

Since the question asks us the value of S, we can simplify the equation again as follows:

$$S = M + (3/8)T$$

Thus, in order to solve for S, we will need to determine the value of both M and T.

The question can be rephrased as, what is the value of  $M + (3/8)T$ ?

NOT SUFFICIENT: The first statement tells us that  $S = (1/5)M$ . This gives us no information about T so statement one alone is not sufficient.

SUFFICIENT: The second statement tells us that  $M = (1/2)L = \$1$  million.

Additionally, since we know from the question that  $L = (5/8)T$ , then M must be equal to  $1/2$  of  $5/8(T)$  or  $5/16(T)$ . We can therefore solve for T as follows:

$$\begin{array}{r} M = \$1,000,000 \\ = \end{array} \quad \frac{5}{16} \quad T \quad = \quad \$3,200,000 = T$$

We can now easily solve for S:

$$L + M + S = T$$

$$2 \text{ million} + 1 \text{ million} + S = \$3.2 \text{ million}$$

$$S = .2 \text{ million}$$

The correct answer is B.

15.

The question asks us to solve for the ratio of pennies ( $p$ ) to dimes ( $d$ ).

INSUFFICIENT: This tells us that the ratio of nickels ( $n$ ) to dimes ( $d$ ) is 3:2. This gives us no information about the ratio of pennies to dimes.

INSUFFICIENT: This tells us that there is \$7, or 700 cents in the piggy bank. We can write an equation for this as follows, using the value of each type of coin:  $10d + 5n + p = 700$ . This is not enough information for us to figure out the ratio of  $p$  to  $d$ .

(1) AND (2) INSUFFICIENT: Taken together, both statements still do not provide enough information for us to figure out the ratio of  $p$  to  $d$ . For example, there may be 3 nickels, 2 dimes, and 665 pennies in the piggy bank (this keeps the ratio of nickels to dimes at 3:2 and totals to \$7). Alternatively, there may be 30 nickels, 20 dimes, and 350 pennies (this also keeps the ratio of nickels to dimes at 3:2 and totals to \$7). In these 2 cases the ratio of pennies to dimes is not the same.

The correct answer is E.

16. To determine the ratio of Chemical A to Chemical C, we need to find the amount of each in the solution. The question stem already tells us that there are 10 milliliters of Chemical C in the final solution. We also know that the original solution consists of only Chemicals A and B in the ratio of 3 to 7. Thus, we simply need the original volume of the solution to determine the amount of Chemical A contained in it.

SUFFICIENT: This tells us that original solution was 50 milliliters. Thus, there must have been 15 milliliters of Chemical A (to 35 milliliters of Chemical B). The ratio of A to C is 15 to 10 (or 3 to 2).

SUFFICIENT: This tells us that the final solution was 60 milliliters. We know that this includes 10 milliliters of Chemical C. This means the original solution contained 50 milliliters. Thus, there must have been 15 milliliters of Chemical A (to 35 milliliter of Chemical B). The ratio of A to C is 15 to 10 (or 3 to 2).

The correct answer is D.

17.

Given woman: children=5:2

1). children: man=5:11, you agree it is insufficient

2).  $W < 30$ , you also agree it alone is insufficient

Together, w:c:m = 25:10:22 (all have to be integers!) thus w=25 and m=22.

Answer is C

18.

Premise: one serving includes a certain number of dishes.(we don't know the exact number),and a dish requires  $\frac{3}{2}$  cups of pasta.( it means  $4Y=mX$ , and  $X=\frac{3}{2}$ pasta.)

Question:  $nY$  require how many cups of pasta?

1). if Malik make  $X$  servings next time. He did prepare  $2X$  dishes last time.

2). Malik used 6 cups of pasta the last time he prepared this dish.(it means  $2X=6$ ).

In this case, either condition one or condition two cannot deduce the final answer in that the decisive factors  $m, n$  are unknown.

As a result, the correct answer is C.

# STATISTICS

## MEAN

1. A
2. C
3. E
4. This question deals with weighted averages. A weighted average is used to combine the averages of two or more subgroups and to compute the overall average of a group. The two subgroups in this question are the men and women. Each subgroup has an average weight (the women's is given in the question; the men's is given in the first statement). To calculate the overall average weight of the group, we would need the averages of each subgroup along with the ratio of men to women. The ratio of men to women would determine the weight to give to each subgroup's average. However, this question is not asking for the weighted average, but is simply asking for the ratio of women to men (i.e. what percentage of the competitors were women).  
(1) INSUFFICIENT: This statement merely provides us with the average of the other subgroup – the men. We don't know what weight to give to either subgroup; therefore we don't know the ratio of the women to men.  
(2) SUFFICIENT: If the average weight of the entire group was twice as close to the average weight of the men as it was to the average weight of the women, there must be twice as many men as women. With a 2:1 ratio of men to women of, 33 1/3% (i.e. 1/3) of the competitors must have been women. Consider the following rule and its proof.  
RULE: The ratio that determines how to weight the averages of two or more subgroups in a weighted average ALSO REFLECTS the ratio of the distances from the weighted average to each subgroup's average.  
Let's use this question to understand what this rule means. If we start from the solution, we will see why this rule holds true. The average weight of the men here is 150 lbs, and the average weight of the women is 120 lbs. There are twice as many men as women in the group (from the solution) so to calculate the weighted average, we would use the formula  $[1(120) + 2(150)] / 3$ . If we do the math, the overall weighted average comes to 140.  
Now let's look at the distance from the weighted average to the average of each subgroup.  
Distance from the weighted avg. to the avg. weight of the men is  $150 - 140 = 10$ .  
Distance from the weighted avg. to the avg. weight of the women is  $140 - 120 = 20$ .  
Notice that the weighted average is twice as close to the men's average as it is to the women's average, and notice that this reflects the fact that there were twice as many men as women. In general, the ratio of these distances will always reflect the relative ratio of the subgroups.  
The correct answer is (B), Statement (2) ALONE is sufficient to answer the question, but statement (1) alone is not.
5. First, let's use the average formula to find the current mean of set  $S$ : Current mean of set  $S =$   
(sum of the terms)/(number of terms): (sum of the terms) =  $(7 + 8 + 10 + 12 + 13) = 50$   
(number of terms) =  $5 \quad 50/5 = 10$

Mean of set  $S$  after integer  $n$  is added =  $10 \times 1.2 = 12$       Next, we can use the new average to find the sum of the elements in the new set and compute the value of integer  $n$ . Just make sure that you remember that after integer  $n$  is added to the set, it will contain 6 rather than 5 elements.      Sum of all elements in the new set = (average)  $\times$  (number of terms) =  $12 \times 6 = 72$       Value of integer  $n$  = sum of all elements in the new set – sum of all elements in the original set =  $72 - 50 = 22$       The correct answer is D.

6. Let  $x$  = the number of 20 oz. bottles       $48 - x$  = the number of 40 oz. bottles      The average volume of the 48 bottles in stock can be calculated as a weighted average:

$$\frac{x(20) + (48 - x)(40)}{48} = 35$$

$x = 12$

Therefore there are 12 twenty oz. bottles and  $48 - 12 = 36$  forty oz. bottles in stock. If no twenty oz. bottles are to be sold, we can calculate the number of forty oz. bottles it would take to yield an average volume of 25 oz:  
Let  $n$  = number of 40 oz. bottles

$$\frac{(12)(20) + (n)(40)}{n + 12} = 25$$

$$(12)(20) + 40n = 25n + (12)(25)$$

$$15n = (12)(25) - (12)(20)$$

$$15n = (12)(25 - 20)$$

$$15n = (12)(5)$$

$$15n = 60$$

$$n = 4$$

Since it would take 4 forty oz. bottles along with 12 twenty oz. bottles to yield an average volume of 25 oz,  $36 - 4 = 32$  forty oz. bottles must be sold. The correct answer is D.

7. The average number of vacation days taken this year can be calculated by dividing the total number of vacation days by the number of employees. Since we know the total number of employees, we can rephrase the question as: How many total vacation days did the employees of Company X take this year?

(1) INSUFFICIENT: Since we don't know the specific details of how many vacation days each employee took the year before, we cannot determine the actual numbers that a 50% increase or a 50% decrease represent. For example, a 50% increase for someone who took 40 vacation days last year is going to affect the overall average more than the same percentage increase for someone who took only 4 days of vacation last year.

(2) SUFFICIENT: If three employees took 10 more vacation days each, and two employees took 5 fewer vacation days each, then we can calculate how the number of vacation days taken this year differs from the number taken last year:

$$(10 \text{ more days/employee})(3 \text{ employees}) - (5 \text{ fewer days/employee})(2 \text{ employees}) = 30 \text{ days} - 10 \text{ days} = 20 \text{ days}$$

**20 additional vacation days were taken this year.**

In order to determine the total number of vacation days taken this year (i.e., in order to answer the rephrased question), we need to determine the number of vacation days taken last year. The 5 employees took an average of 16 vacation days each last year, so the total number of vacation days taken last year can be determined by taking the product of the two:

$$(5 \text{ employees})(16 \text{ days/employee}) = 80 \text{ days}$$

**80 vacation days were taken last year.** Hence, **the total number of vacation days taken**

**this year was 100 days.**

Note: It is not necessary to make the above calculations -- it is simply enough to know that you have enough information in order to do so (i.e., the information given is sufficient)! The correct answer is B.

8. The question is asking us for the *weighted* average of the set of men and the set of women. To find the weighted average of two or more sets, you need to know the average of each set and the ratio of the number of members in each set. Since we are told the average of each set, this question is really asking for the ratio of the number of members in each set. (1) SUFFICIENT: This tells us that there are twice as many men as women. If  $m$  represents the number of men and  $w$  represents the number of women, this statement tells us that  $m = 2w$ . To find the weighted average, we can sum the total weight of all the men and the total weight of all the women, and divide by the total number of people. We have an equation as follows:  
$$M * 150 + F * 120 / M + F$$
Since this statement tells us that  $m = 2w$ , we can substitute for  $m$  in the average equation and average now = 140. Notice that we don't need the actual number of men and women in each set but just the ratio of the quantities of men to women.  
(2) INSUFFICIENT: This tells us that there are a total of 120 people in the room but we have no idea how many men and women. This gives us no indication of how to weight the averages. The correct answer is A.

9. The formula for calculating the average (arithmetic mean) home sale price is as follows:

Average =  $\frac{\text{sum of home sale prices}}{\text{number of homes sold}}$  A suitable rephrase of this question is "What was the sum of the homes sale prices, and how many homes were sold?"

(1) SUFFICIENT: This statement tells us the sum of the home sale prices and the number of homes sold. Thus, the average home price is  $\$51,000,000/100 = \$510,000$ .

(2) INSUFFICIENT: This statement tells us the average condominium price, but not all of the homes sold in Greenville last July were condominiums. From this statement, we don't know anything about the other 40% of homes sold in Greenville, so we cannot calculate the average home sale price. Mathematically:

Average =  $\frac{\text{sum of condominium sale prices} + \text{sum of non-condominium sale prices}}{\text{number of condominiums sold} + \text{number of non-condominiums sold}}$

We have some information about the ratio of number of condominiums to non-condominiums sold, 60%:40%, or 6:4, or 3:2, which could be used to pick working numbers for the total number of homes sold. However, the average still cannot be calculated because we don't have any information about the non-condominium prices.

The correct answer is A.

10. We know that the average of  $x$ ,  $y$ , and  $z$  is 11. We can therefore set the up the following equation:

$$(x + y + z)/3 = 11$$

Cross-multiplying yields

$$x + y + z = 33$$

Since  $z$  is two more than  $x$ , we can replace  $z$ .

$$x + y + x + 2 = 33$$

$$2x + y + 2 = 33$$

$$2x + y = 31$$

Since  $2x$  must be even and 31 is odd,  $y$  must also be odd (only odd + even = odd).  $x$  and  $z$  can be either odd or even. Therefore, only statement II ( $y$  is odd) must be true.

The correct answer is B.

11. It helps to recognize this problem as a consecutive integers question. The median of a set of consecutive integers is equidistant from the extreme values of the set. For example, in the set  $\{1, 2, 3, 4, 5\}$ , the median is 3, which is 2 away from 1 (the smallest value) and 2 away from 5 (the largest value). Therefore, the median of Set  $A$  must be equidistant from the extreme values of that set, which are  $x$  and  $y$ . So the distance from  $x$  to 75 must be the same as the distance from 75 to  $y$ . We can express this algebraically:  $75 - x = y - 75$        $150 - x = y$        $150 = y + x$
- We are asked to find the value of  $3x + 3y$ . This is equivalent to  $3(x + y)$ . Since  $x + y = 150$ , we know that  $3(x + y) = 3(150) = 450$ . Alternatively, the median of a set of consecutive integers is equal to the average of the extreme values of the set. For example, in the set  $\{1, 2, 3, 4, 5\}$ , the median is 3, which is also the average of 1 and 5. Therefore, the median of set  $A$  will be the average of  $x$  and  $y$ . We can express this algebraically:  $(x + y)/2 = 75$        $x + y = 150$
- $3(x + y) = 3(150)$        $3x + 3y = 450$  The correct answer is D.

**12.**

We're asked to determine whether the average number of runs, per player, is greater than 22. We are given one piece of information in the question stem: the ratio of the number of players on the three teams.

The simple average formula is just  $A = S/N$  where  $A$  is the average,  $S$  is the total number of runs and  $N$  is the total number of players. We have some information about  $N$ : the ratio of the number of players. We have no information about  $S$ .

SUFFICIENT. Because we are given the individual averages for the team, we do not need to know the actual number of members on each team. Instead, we can use the ratio as a proxy for the actual number of players. (In other words, we don't need the actual number; the ratio is sufficient because it is in the same proportion as the actual numbers.) If we know both the average number of runs scored and the ratio of the number of players, we can use the data to calculate:

# RUNS	RELATIVE # PLAYERS	R*P
30	2	60
17	5	85
25	3	75

The  $S$ , or total number of runs, is  $60 + 85 + 75 = 220$ . The  $N$ , or number of players, is  $2 + 5 + 3 = 10$ .  $A = 220/10 = 22$ . The collective, or weighted, average is 22, so we can definitively answer the question: No. (Remember that "no" is a sufficient answer. Only "maybe" is insufficient.)

INSUFFICIENT. This statement provides us with partial information about  $S$ , the sum, but we need to determine whether it is sufficient to answer the question definitively. "Is at least" means  $S$  is greater than or equal to 220. We know that the minimum number of players, or  $N$ , is 10 (since we can't have half a player). If  $N$  is 10 and  $S$  is 220, then  $A$  is  $220/10 = 22$  and we can answer the question No: 22 is not greater than 22. If  $N$  is 10 and  $S$  is 221, then  $A$  is  $221/10 = 22.1$  and we can answer the question Yes: 22.1 is greater than 22. We cannot answer the question definitively with this information.

The correct answer is A.

## MEDIAN

1. E
2. E
3. A

4.

One approach to this problem is to try to create a Set  $T$  that consists of up to 6 integers and has a median equal to a particular answer choice. The set  $\{-1, 0, 4\}$  yields a median of 0. Answer choice A can be eliminated. The set  $\{1, 2, 3\}$  has an average of 2. Thus,  $x = 2$ . The median of this set is also 2. So the median =  $x$ . Answer choice B can be eliminated. The set  $\{-4, -2, 12\}$  has an average of 2. Thus,  $x = 2$ . The median of this set is  $-2$ . So the median =  $-x$ . Answer choice C can be eliminated. The set  $\{0, 1, 2\}$  has 3 integers. Thus,  $y = 3$ . The median of this set is 1. So the median of the set is  $(1/3)y$ . Answer choice D can be eliminated. As for answer choice E, there is no possible way to create Set  $T$  with a median of  $(2/7)y$ . Why? We know that  $y$  is either 1, 2, 3, 4, 5, or 6. Thus,  $(2/7)y$  will yield a value that is some fraction with denominator of 7.

The possible values of  $(2/7)y$  are as follows:  $\frac{2}{7}, \frac{4}{7}, \frac{6}{7}, \frac{1}{7}, \frac{3}{7}, \frac{5}{7}$

However, the median of a set of integers must always be either an integer or a fraction with a denominator of 2 (e.g. 2.5, or  $5/2$ ). So  $(2/7)y$  cannot be the median of Set  $T$ . The correct answer is E.

5. Since  $S$  contains only consecutive integers, its median is the average of the extreme

values  $a$  and  $b$ . We also know that the median of  $S$  is  $\frac{3}{4}b$ . We can set up and simplify the following equation:

$$\begin{aligned}\frac{a+b}{2} &= \frac{3b}{4} \rightarrow \\ 4a+4b &= 6b \rightarrow \\ 4a &= 2b \rightarrow \\ 2a &= b\end{aligned}$$

Since set  $Q$  contains only consecutive integers, its median is also the average of the

extreme values, in this case  $b$  and  $c$ . We also know that the median of  $Q$  is  $\frac{7}{8}c$ . We can set up and simplify the following equation:

$$\begin{aligned}\frac{b+c}{2} &= \frac{7c}{8} \rightarrow \\ 8b+8c &= 14c \rightarrow \\ 8b &= 6c \rightarrow \\ 4b &= 3c\end{aligned}$$

We can find the ratio of  $a$  to  $c$  as follows: Taking the first equation,  $2a = b \rightarrow 8a = 4b$

and the second equation,  $4b = 3c$  and setting them equal to each other, yields the following:

$8a = 3c \rightarrow \frac{a}{c} = \frac{3}{8}$ . Since set  $R$  contains only consecutive integers, its median is the average of the extreme values  $a$  and  $c$ :  $\frac{a+c}{2}$ . We can use the ratio  $\frac{a}{c} = \frac{3}{8}$  to substitute  $\frac{3c}{8}$  for  $a$ :

$$\frac{\frac{3c}{8} + c}{2} \rightarrow \frac{\frac{11c}{8}}{2} \rightarrow \frac{11}{16}c$$

Thus the median of set  $R$  is  $\frac{11}{16}c$ . The correct answer is C.

6. From the question stem, we know that Set A is composed entirely of all the members of Set B plus all the members of Set C. The question asks us to compare the median of Set A (the combined set) and the median of Set B (one of the smaller sets). Statement (1) tells us that **the mean of Set A is greater than the median of Set B**. This gives us no useful information to compare the medians of the two sets. To see this, consider the following: Set B: { 1, 1, 2 }, Set C: { 4, 7 }, Set A: { 1, 1, 2, 4, 7 }. In the example above, the mean of Set A (3) is greater than the median of Set B (1) and the median of Set A (2) is **GREATER** than the median of Set B (1). However, consider the following example: Set B: { 4, 5, 6 }, Set C: { 1, 2, 3, 21 }, Set A: { 1, 2, 3, 4, 5, 6, 21 }, Here the mean of Set A (6) is greater than the median of Set B (5) and the median of Set A (4) is **LESS** than the median of Set B (5). This demonstrates that Statement (1) alone does not suffice to answer the question. Let's consider Statement (2) alone: **The median of Set A is greater than the median of Set C**. By definition, the median of the combined set (A) must be any value at or between the medians of the two smaller sets (B and C). Test this out and you'll see that it is always true. Thus, before considering Statement (2), we have three possibilities: Possibility 1: The median of Set A is greater than the median of Set B but less than the median of Set C.



- Possibility 2: The median of Set A is greater than the median of Set C but less than the median of Set B.



Possibility 3: The median of Set A is equal to the median of Set B or the median of Set C. Statement (2) tells us that the median of Set A is greater than the median of Set C. This eliminates Possibility 1, but we are still left with Possibility 2 and Possibility 3. The median of Set B may be greater than OR equal to the median of Set A. Thus, using Statement (2) we cannot determine whether the median of Set B is greater than the median of Set A. Combining Statements (1) and (2) still does not yield an answer to the question, since Statement (1) gives no relevant information that compares the two medians and Statement (2) leaves open more than one possibility. Therefore, the correct answer is Choice **(E): Statements (1) and (2) TOGETHER are NOT sufficient.**

7. To find the mean of the set  $\{6, 7, 1, 5, x, y\}$ , use the average formula:  $A = \frac{S}{n}$  where  $A$  = the average,  $S$  = the sum of the terms, and  $n$  = the number of terms in the set. Using the information given in statement (1) that  $x + y = 7$ , we can find the mean:

$$\frac{6+7+1+5+(x+y)}{6} = \frac{6+7+1+5+7}{6} = 4\frac{1}{3}$$

Regardless of the values of  $x$  and  $y$ , the

mean of the set is  $4\frac{1}{3}$  because the sum of  $x$  and  $y$  does not change. To find the median, list the possible values for  $x$  and  $y$  such that  $x + y = 7$ . For each case, we can calculate the median.

$x$	$y$	DATA SET	MEDIAN
1	6	1, 1, 5, 6, 6, 7	5.5
2	5	1, 2, 5, 5, 6, 7	5
3	4	1, 3, 4, 5, 6, 7	4.5
4	3	1, 3, 4, 5, 6, 7	4.5
5	2	1, 2, 5, 5, 6, 7	5
6	1	1, 1, 5, 6, 6, 7	5.5

Regardless of the values of  $x$  and  $y$ , the median (4.5, 5, or 5.5) is always greater than the

mean ( $4\frac{1}{3}$ ). Therefore, statement (1) alone is sufficient to answer the question. Now consider statement (2). Because the sum of  $x$  and  $y$  is not fixed, the mean of the set will vary.

Additionally, since there are many possible values for  $x$  and  $y$ , there are numerous possible medians. The following table illustrates that we can construct a data set for which  $x - y = 3$  and the *mean* is greater than the median. The table ALSO shows that we can construct a data set for which  $x - y = 3$  and the *median* is greater than the mean.

$x$	$y$	DATA SET	MEDIAN	MEAN
22	19	1, 5, 6, 7, 19, 22	6.5	10
4	1	1, 1, 4, 5, 6, 7	4.5	4

Thus, statement (2) alone is not sufficient to determine whether the mean is greater than the median. The correct answer is (A): Statement (1) alone is sufficient, but statement (2) alone is not sufficient.

### 8. Median > Mean

9. The set  $R_n = R_{n-1} + 3$  describes an evenly spaced set: each value is three more than the previous. For example the set could be 3, 6, 9, 12 . . . For any evenly spaced set, the mean of the set is always equal to the median. A set of consecutive integers is an example of an evenly spaced set. If we find the mean of this set, we will be able to find the median because they are the same. (1) INSUFFICIENT: This does not give us any information about the value of the mean. The only other way to find the median of a set is to know every term of the set. (2) SUFFICIENT: The mean must be the median of the set since this is an evenly spaced set. This statement tells us that mean is 36. Therefore, the median must be 36. The correct answer is B.

10. This question is asking us to find the median of the three scores. It may seem that the only way to do this is to find the value of each of the three scores, with the middle value taken as the median. Using both statements, we would have two of the three scores, along with the mean given in the question, so we would be able to find the value of the third score. It would seem then that the answer is C. On GMAT data sufficiency, always be suspicious, however, of such an obvious C. In such cases, one or both of the statements is often sufficient. (1) INSUFFICIENT: With an arithmetic mean of 78, the sum of the three scores is  $3 \times 78 = 234$ . If Peter scored 73, the other two scores must sum to  $234 - 73 = 161$ . We could come up with hundreds of sets of scores that fit these conditions and that have different medians. An example of just two sets are:  
 73, 80, 81 median = 80                      61, 73, 100 median = 73                      (2)  
 SUFFICIENT: On the surface, this statement seems parallel to statement (1) and should therefore also be insufficient. However, we aren't just given one of the three scores in this statement. We are given a score with a value that is THE SAME AS THE MEAN. Conceptually, the mean is the point where the deviations of all the data net zero. This means that the sum of the differences from the mean to each of the points of data must net to zero. For a simple example, consider 11, which is the mean of 7, 10 and 16.  $7 - 11 = -4$  (defined as negative because it is left of the mean on the number line)       $10 - 11 = -1$        $16 - 11 = +5$  (defined as positive because it is right of the mean on the number line)      The positive and negative deviations (differences from the mean) net to zero. In the question, we are told that the mean score is 78 and that Mary scored a 78. Mary's deviation then is  $78 - 78 = 0$ . For the deviations to net to zero, Peter and Paul's deviations must be  $-x$  and  $+x$  (not necessarily in that order).  
 Mary's deviation =  $78 - 78 = 0$       Peter's (or Paul's) deviation =  $-x$                       Paul's (or Peter's) deviation =  $+x$   
 We can then list the data in order:  $78 - x, 78, 78 + x$  This means that the median must be 78.  
 NOTE:  $x$  could be 0, which would simply mean that all three students scored a 78. However, the median would remain 78.  
 The correct answer is B.

11. Since each set has an even number of terms, the median of each set will be equal to the average of the two middle terms of that set. So, the median of Set A will be equal to the average of  $x$  and 8. The median of Set B will be equal to the average of  $y$  and 9. The question tells us that the median of Set A is equal to the median of Set B. We can express this algebraically as

$$\frac{x + 8}{2} = \frac{y + 9}{2}$$

We can multiply both sides by 2:

$$x + 8 = y + 9$$

We can subtract  $x$  from both sides (remember, we are looking for  $y - x$ ):

$$8 = y - x + 9$$

We can subtract 9 from both sides to isolate  $y - x$ :

$$y - x = 8 - 9 = -1$$

The correct answer is B.

12. To find the maximum possible value of  $x$ , we'll first consider that the set's mean is 7, and then that its median is 5.5.

For any set, the sum of the elements equals the mean times the number of elements. In this case, the mean is 7 and the number of elements is 6, so the sum of the elements equals 42.

$$42 = 8 + 2 + 11 + x + 3 + y$$

$$42 = 24 + x + y$$

$$18 = x + y$$

Now consider that the median is 5.5. Letting  $x = 1$  and  $y = 17$  such that they sum to 18, we can arrange the values in increasing order as follows:

$$x, 2, 3, 8, 11, y$$

Since 3 and 8 are the middle values, the median equals 5.5 as required. The question asks for the maximal value of  $x$ , so let's increase  $x$  as far as possible without changing the median. As  $x$  increases to 3 (and  $y$  decreases to 15), the middle values of 3 and 8 don't change, so the median remains at 5.5. However, as  $x$  increases beyond 3, the median also increases, so the maximal value of  $x$  that leaves the median at 5.5 is 3.

The correct answer is D.

**13.**

From 1, we know that  $n < 5$ , 1,  $n$ , 5, 8

From 2, we know that  $n > 1$ , 1,  $n$ , 5, 8

Combined two, we can know that  $1 < n < 5$

The answer is C

**14.**

To get the maximum length of the shortest piece, we must let other values as little as possible. That is, the values after the median should equal the median, and the value before the median should be equal to each other.

Let the shortest one be  $x$ :

$$x + x + 140 \cdot 3 = 124 \cdot 5$$

$$x = 100$$

## MODE

1. -8
- 2.

Statement 1 tells us that the difference between any two integers in the set is less than 3. This information alone yields a variety of possible sets. For example, one possible set (in which the difference between any two integers is less than 3) might be:  $(x, x, x, x + 1, x + 1, x + 2, x + 2)$ . Mode =  $x$  (as stated in question stem). Median =  $x + 1$ . Difference between median and mode = 1.

Alternately, another set (in which the difference between any two integers is less than 3) might look like this:  $(x - 1, x, x, x + 1)$ . Mode =  $x$  (as stated in the question stem). Median =  $x$ . Difference between median and mode = 0. We can see that statement (1) is not sufficient to determine the difference between the median and the mode.

Statement (2) tells us that the average of the set of integers is  $x$ . This information alone also yields a variety of possible sets. For example, one possible set (with an average of  $x$ ) might be:  $(x - 10, x, x, x + 1, x + 2, x + 3, x + 4)$ . Mode =  $x$  (as stated in the question stem). Median =  $x + 1$ . Difference between median and mode = 1.

Alternately, another set (with an average of  $x$ ) might look like this:  $(x - 90, x, x, x + 15, x + 20, x + 25, x + 30)$ . Mode =  $x$  (as stated in the question stem). Median =  $x + 15$ .

Difference between median and mode = 15. We can see that statement (2) is not sufficient to determine the difference between the median and the mode. Both statements taken together imply that the only possible members of the set are  $x - 1, x$ , and  $x + 1$  (from the fact that the difference between any two integers in the set is less than 3) and that every  $x - 1$  will be balanced by an  $x + 1$  (from the fact that the average of the set is  $x$ ). Thus,  $x$  will lie in the middle of any such set and therefore  $x$  will be the median of any such set. If  $x$  is the mode and  $x$  is also the median, the difference between these two measures will always be 0. The correct answer is C: BOTH statements TOGETHER are sufficient, but NEITHER statement ALONE is sufficient.

## RANGE

1. C
2. E
3. A
4. D
5. C
6. C
7. B
8. B
9. E

10.

Before analyzing the statements, let's consider different scenarios for the range and the median of set A. Since we have an even number of integers in the set, the median of the set will be equal to the average of the two middle numbers. Further, note that integer 2 is the only even prime and it cannot be one of the two middle numbers, since it is the smallest of all primes. Therefore, both of the middle primes will be odd, their sum will be even, and their average (i.e. the median of the set) will be an integer. However, while we know that the median will be an integer, it is unknown whether this integer will be even or odd. For example, the average of 7 and 17 is 12 (even), while the average of 5 and 17 is 11 (odd).

Next, let's consider the possible scenarios with the range. Remember that the range is the difference between the greatest and the smallest number in the set. Since we are dealing with prime numbers, the greatest prime in the set will always be odd, while the smallest one can be either odd or even (i.e. 2). If the smallest prime in the set is 2, then the range will be odd, otherwise, the range will be even. Now, let's consider these scenarios in light of each of the statements. (1) SUFFICIENT: If the smallest prime in the set is 5, the range of the set, i.e. the difference between two odd primes in this case, will be even. Since the median of the set will always be an integer, the product of the median and the range will always be even. (2) INSUFFICIENT: If the largest integer in the set is 101, the range of the set can be odd or even (for example,  $101 - 3 = 98$  or  $101 - 2 = 99$ ). The median of the set can also be odd or even, as we discussed. Therefore, the product of the median and the range can be either odd or even. The correct answer is A.

11. (1) INSUFFICIENT: Statement (1) tells us that the range of  $S$  is less than 9. The range of a set is the positive difference between the smallest term and the largest term of the set. In this case, knowing that the range of set  $S$  is less than 9, we can answer only MAYBE to the question "Is  $(x + y) < 18$ ". Consider the following two examples: Let  $x = 7$  and  $y = 7$ . The range of  $S$  is less than 9 and  $x + y < 18$ , so we conclude YES. Let  $x = 10$  and  $y = 10$ . The range of  $S$  is less than 9 and  $x + y > 18$ , so we conclude NO. Because this statement does not allow us to answer definitively Yes or No, it is insufficient. (2) SUFFICIENT: Statement (2) tells us that the average of  $x$  and  $y$  is less than the average of the set  $S$ . Writing this as an inequality:  $(x + y)/2 < (7 + 8 + 9 + 12 + x + y)/6$ ;  $(x + y)/2 < (36 + x + y)/6$ ;  $3(x + y) < 36 + (x + y)$ ;  $2(x + y) < 36$ ;  $x + y < 18$ . Therefore, statement (2) is SUFFICIENT to determine whether  $x + y < 18$ .
12. Since the GMAT is scored in 10-point increments, we know from statement (1) that there are a maximum of 19 distinct GMAT scores among the students in the first-year class (600, 610 . . . 770, 780). We also know that there are 12 months in a year, yielding 12 distinct possibilities for the birth month of a student. Finally, there are 2 possibilities for student gender. Therefore, the number of distinct combinations consisting of a GMAT score, the month of birth, and gender is  $19 \times 12 \times 2 = 456$ . Because the total number of students is greater than the maximum number of distinct combinations of GMAT score/month of birth/gender, some students must share the same combination. That is, some students must have the same gender, be born in the same month, and have the same GMAT score. Thus, statement (1) is sufficient to answer the question. Statement (2) provides no information about the range of student GMAT scores in the first-year class. Since there are 61 distinct GMAT scores between 200 and 800, the total number of distinct combinations of GMAT score/month of birth/gender on the basis of statement (2) is  $61 \times 12 \times 2 = 1,464$ . Since this number is greater than the first-year enrolment, there are potentially enough unique combinations to cover all of the students, implying that there may or may not be some students sharing the same 3 parameters. Since we cannot give a conclusive answer to the question, statement (2) is insufficient.

The correct answer is A.

13. From Statement (1) alone, we can conclude that the range of the terms of  $S$  is either 3 or 7. (These are the prime numbers less than 11, excluding 2 and 5, which are both factors of 10.) Since the question states that the range of  $S$  is equal to the average of  $S$ , we know that the average of the terms in  $S$  must also be either 3 or 7. This alone is not sufficient to answer the

question. From Statement (2) alone, we know that  $S$  is composed of exactly 5 different integers. This means that the smallest possible range of the terms in  $S$  is 4. (This would occur if the 5 different integers are consecutive.) This is not sufficient to answer the question.

From Statements (1) and (2) together, we know that the range of the terms in  $S$  must be 7. This means that the average of the terms in  $S$  is also 7. It may be tempting to conclude from this that the sum of the terms in  $S$  is equal to the average (7) multiplied by the number of terms (5) =  $7 \times 5 = 35$ . However, while Statement (2) says that  $S$  is composed of 5 different integers, this does not mean that  $S$  is composed of exactly 5 integers since each integer may occur in  $S$  more than once. Two contrasting examples help to illustrate this point:  $S$  could be the set  $\{3, 6, 7, 9, 10\}$ . Here, the range of  $S =$  the average of  $S = 7$ . Additionally,  $S$  is composed of 5 different integers and the sum of all the integers in  $S$  is 35.  $S$  could also be the set  $\{3, 6, 7, 7, 9, 10\}$ . Here, the range of  $S =$  the average of  $S = 7$ . Again,  $S$  is composed of 5 different integers. However, here the sum of  $S$  is 42 (since one of the integers, 7, appears twice.). The correct answer is E: Statements (1) and (2) TOGETHER are NOT sufficient.

14. In a set consisting of an odd number of terms, the median is the number in the middle when the terms are arranged in ascending order. In a set consisting of an even number of terms, the median is the average of the two middle numbers. If  $S$  has an odd number of terms, we know that the median must be the middle number, and thus the median must be even (because it is a set of even integers). If  $S$  has an even number of terms, we know that the median must be the average of the two middle numbers, which are both even, and the average of two consecutive even integers must be odd, and so therefore the median must be odd. The question can be rephrased: "Are there an even number of terms in the set?"

(1) SUFFICIENT: Let  $X_1$  be the first term in the set and let its value equal  $x$ . Since  $S$  is a set of consecutive even integers,  $X_2 = X_1 + 2$ ,  $X_3 = X_1 + 4$ ,  $X_4 = X_1 + 6$ , and so on. Recall that the mean of a set of evenly spaced integers is simply the average of the first and last term. Construct a table as follows:

$X_n$	Value	Ave $n$ Terms	Result	O or E
$X_1$	$x$	$x$	$x$	Even
$X_2$	$x + 2$	$2x + 2$	$x + 1$	Odd
$X_3$	$x + 4$	$3x + 6$	$x + 2$	Even
$X_4$	$x + 6$	$4x + 10$	$x + 3$	Odd
$X_5$	$x + 8$	$5x + 14$	$x + 4$	Even

Note that when there is an even number of terms, the mean is odd and when there are an odd number of terms, the mean is even. Hence, since (1) states that the mean is even, it follows that the number of terms must be odd. This is sufficient to answer the question (the answer is "no"). Note of caution: it doesn't matter whether the answer to the question is "yes" or "no"; it is only important to determine whether it is *possible* to answer the question given the information in the statement.

Alternatively, we can recognize that, in a set of consecutive numbers, the median is equal to the mean, and so the median must be even.

(2) INSUFFICIENT: Let  $X_1$  be the first term in the set and let its value =  $x$ . The range of a set is defined as the difference between the largest value and the smallest value. Construct a table as follows:

Term	Value	Range $n$ Terms	Div by 6?
$X_1$	$X$		
$X_2$	$x + 2$	2	No
$X_3$	$x + 4$	4	No
<b><math>X_4</math></b>	<b><math>x + 6</math></b>	<b>6</b>	<b>Yes</b>
$X_5$	$x + 8$	8	No
$X_6$	$x + 10$	10	No
<b><math>X_7</math></b>	<b><math>x + 12</math></b>	<b>12</b>	<b>Yes</b>

Note that if there are 4 terms in the set, the range of the set is divisible by 6, while if there are 7 terms in the set, the range of the set is still divisible by 6. Hence, it cannot be determined whether the number of terms in the set is even or odd based on whether the range of the set is divisible by 6. The correct answer is A.

15. The median of a set of numbers is the middle number when the numbers are arranged in increasing order. For a set of 5 scores, the median is the 3rd score. We will call the set of scores  $A = \{A_1, A_2, A_3, A_4, A_5\}$  and  $B = \{B_1, B_2, B_3, B_4, B_5\}$  for Dr. Adams' and Dr. Brown's students, respectively, where the scores are arranged in increasing order within each set. Rephrasing the question using this notation yields "Is  $A_3 > B_3$ ?" (1) INSUFFICIENT: This statement tells us only the highest and lowest score for each set of students, but the only thing we know about the scores in between is that they are somewhere in that range. Since the median is one of the scores in between, this uncertainty means that the statement is insufficient. To illustrate,  $A_3$  could be greater than  $B_3$ , making the answer to the question "yes":  $A = \{40, 50, \mathbf{60}, 70, 80\}$   
 $B = \{50, 55, \mathbf{55}, 80, 90\}$  However,  $A_3$  could be less than or equal to  $B_3$ , making the answer to the question "no":  
 $A = \{40, 50, \mathbf{60}, 70, 80\}$   $B = \{50, 60, \mathbf{70}, 80, 90\}$  (2) SUFFICIENT: This statement tells us that for every student pair, the  $B$  student scored higher than the  $A$  student, or  $B_n > A_n$ . This statement can be considered qualitatively. Every student in set  $B$  scored higher than *at least one* student in set  $A$ . The students in set  $B$  not only scored higher individually, but also as a group, so one can reason that the median score for set  $B$  is higher than the median score for set  $A$ . Therefore,  $B_3 > A_3$ , and the answer to the question is "no." But let's prove conclusively that the answer cannot be "yes." Constrain  $A_3$  to be greater than  $B_3$ , then try to pair the students according to the restriction that  $B_n > A_n$ . For example, pick any number  $x$  between 0 and 100, and let's say that  $A_3 > x$ , or high ( $H$ ), and that  $B_3 < x$ , or low ( $L$ ). Since the scores are increasing order, the 1st and 2nd scores must be less than or equal to the 3rd, while the 4th and 5th scores must be greater than or equal to the 3rd. Thus we know whether all the other scores are high or low.  $A = \{A_1, A_2, \mathbf{H}, A_4, A_5\} = \{L, L, \mathbf{H}, H, H\}$   
 $B = \{B_1, B_2, \mathbf{L}, B_4, B_5\} = \{L, L, \mathbf{L}, H, H\}$   
In order to meet the restriction that  $B_n > A_n$ , each of the 3 high scorers ( $H$ ) in set  $A$  must be paired with a high(er) scorer, but there are only 2 high scorers ( $H$ ) in set  $B$ —not enough to go around! Conversely, the 3 low scorers ( $L$ ) in set  $B$  *cannot* be paired with a high scorer ( $H$ ) from set  $A$ , leaving only 2 potential study partners for them from set  $A$ —not enough to go around! There is no way for  $A_3$  to be greater than  $B_3$  and still meet the restriction that  $B_n > A_n$ , so  $A_3 < B_3$ . Thus, the answer can never be "yes," it is always "no," and this statement is sufficient. The correct answer is B.

16.

In order to determine the median of a set of integers, we need to find the "middle" value. (1) SUFFICIENT: Statement one tells us that average of the set of integers from 1 to  $x$  inclusive is 11. Since this is a set of consecutive integers, the "average" term is always the exact middle of the set. Thus, in order to have an average of 11, the set must be the integers from 1 to 21

inclusive. The middle or median term is also 11.

(2) SUFFICIENT: Statement two states that the range of the set of integers from 1 to  $x$  inclusive is 20. In order for the range of integers to be 20, the set must be the integers from 1 to 21 inclusive. The median term in this set is 11. The correct answer is D.

**17.**

Range before transaction:

$$112 - 45 = 67$$

Range after transaction:

$$(94 + 24) - (56 - 20) = 118 - 36 = 82$$

The difference is:  $82 - 67 = 15$

Answer is D

**18.**

Range: the difference between the greatest measurement and the smallest measurement.

In the question, combine 1 and 2, we still cannot know the value of  $q$ , then, we cannot determine which number of is the greatest measurement.

Answer is E

**STANDARD DEVIATION**

1. 1.12 approx
2. D
3. E
4. E
5. C

6. If  $X - Y > 0$ , then  $X > Y$  and the median of  $A$  is greater than the mean of set  $A$ . If  $L - M = 0$ , then  $L = M$  and the median of set  $B$  is equal to the mean of set  $B$ .

I. NOT NECESSARILY: According to the table,  $Z > N$  means that the standard deviation of set  $A$  is greater than that of set  $B$ . Standard deviation is a measure of how close the terms of a given set are to the mean of the set. If a set has a high standard deviation, its terms are relatively far from the mean. If a set has a low standard deviation, its terms are relatively close to the mean.

Recall that a median separates the set into two as far as the number of terms. There is an equal number of terms both above and below the median. If the median of a set is greater than the mean, however, the terms below the median must collectively be *farther* from the median than the terms above the median. For example, in the set  $\{1, 89, 90\}$ , the median is 89 and the mean is 60. The median is much greater than the mean because 1 is much farther from 89 than 90 is.

Knowing that the median of set  $A$  is greater than the mean of set  $A$  just tells us that the terms below set  $A$ 's median are further from the median than the terms above set  $A$ 's median. This does not necessarily imply that the terms, overall, are further away from the mean than in set  $B$ , where the terms below the median are the same distance from the median as the terms above it. In fact, a set in which the mean and median are equal can have a very high standard deviation if the terms are both far below the mean and far above it.

II. NOT NECESSARILY: According to the table,  $R > M$  implies that the mean of set  $[A + B]$  is greater than the mean of set  $B$ . This is not necessarily true. **When two sets are combined to form a composite set, the mean of the composite set must either be between the means of the individual sets or be equal to the mean of both of the individual sets.** To prove this, consider the simple example of one member sets:  $A = [3]$ ,  $B = [5]$ ,  $A + B = [3, 5]$ . In this case the mean of  $A + B$  is greater than the mean of  $A$  and less than the mean of  $B$ . We could easily have reversed this result by reversing the members of sets  $A$  and  $B$ .

III. NOT NECESSARILY: According to the table,  $Q > R$  implies that the median of the set  $[A + B]$  is greater than the mean of set  $[A + B]$ . We can extend the rule given in statement II to medians as well: **when two sets are combined to form a composite set, the median of the composite set must either be between the medians of the individual sets or be equal to the median of one or both of the individual sets.** While the median of set  $A$  is greater than the mean of set  $A$  and the median of set  $B$  is equal to the mean of set  $B$ , set  $[A + B]$  might have a median that is greater or less than the mean of set  $[A + B]$ . See the two tables for illustration:

	Set	Median	Mean	Result
$A$	1, 3, 4	3	2.67	Median > Mean
$B$	4, 5, 6	5	5	Median = Mean
$A + B$	1, 3, 4, 4, 5, 6	4	3.83	Median > Mean

	Set	Median	Mean	Result
$A$	1, 3, 3, 4	3	2.75	Median > Mean
$B$	10, 11, 12	11	11	Median = Mean
$A + B$	1, 3, 3, 4, 10, 11, 12	4	6.29	Median < Mean

Therefore none of the statements are necessarily true and the correct answer is E.

- 7. 65, 85
- 8. 30
- 9.  $aS$
- 10.  $|a/b| \times (S)$

11. Standard deviation is a measure of how far the data points in a set fall from the mean. For example,  $\{5, 5, 6, 7, 7\}$  has a small standard deviation relative to  $\{1, 4, 6, 7, 10\}$ . The values in the second set are much further from the mean than the values in the first set. In general, a value that drastically increases the range of a set will also have a large impact on the standard deviation. In this case, 14 creates the largest spread of the five answer choices, and will therefore be the value that most increases the standard deviation of Set 7. The correct answer is E.
12. The procedure for finding the standard deviation for a set is as follows: 1) Find the difference between each term in the set and the mean of the set. 2) Average the squared "differences." 3)

Take the square root of that average. Notice that the standard deviation hinges on step 1: finding **the difference between each term in the set and the mean of the set**. Once this is done, the remaining steps are just calculations based on these "differences." Thus, we can rephrase the question as follows: "What is the difference between each term in the set and the mean of the set?" (1) SUFFICIENT: From the question, we know that  $Q$  is a set of consecutive integers. Statement 1 tells us that there are 21 terms in the set. Since, in any consecutive set with an odd number of terms, the middle value is the mean of the set, we can represent the set as 10 terms on either side of the middle term  $x$ :  $[x-10, x-9, x-8, x-7, x-6, x-5, x-4, x-3, x-2, x-1, x, x+1, x+2, x+3, x+4, x+5, x+6, x+7, x+8, x+9, x+10]$ . Notice that the difference between the mean ( $x$ ) and the first term in the set ( $x-10$ ) is 10. The difference between the mean ( $x$ ) and the second term in the set ( $x-9$ ) is 9. As you can see, we can actually find the difference between each term in the set and the mean of the set without knowing the specific value of each term in the set! (The only reason we are able to do this is because we know that the set abides by a specified consecutive pattern and because we are told the number of terms in this set.) Since we are able to find the "differences," we can use these to calculate the standard deviation of the set. Although you do not need to do this, here is the actual calculation: Sum of the squared differences:  $10^2 + 9^2 + 8^2 + 7^2 + 6^2 + 5^2 + 4^2 + 3^2 + 2^2 + 1^2 + 0^2 + (-1)^2 + (-2)^2 + (-3)^2 + (-4)^2 + (-5)^2 + (-6)^2 + (-7)^2 + (-8)^2 + (-9)^2 + (-10)^2 = 770$ .

Average of the sum of the squared differences: 
$$\frac{770}{21} = 36\frac{2}{3}$$

The square root of this average is the standard deviation: 
$$\sqrt{36\frac{2}{3}} \approx 6.06$$

(2) NOT SUFFICIENT: Since the set is consecutive, we know that the median is equal to the mean. Thus, we know that the mean is 20. However, we do not know how big the set is so we cannot identify the difference between each term and the mean. Therefore, the correct answer is A.

13.

(1) SUFFICIENT: The average of data set  $B = \{1, 2, 3\}$  is 2. So in data set  $A = \{1, 2, x\}$  as  $x$  increases above 3, it gets further and further from the average. This necessarily increases its standard deviation, so  $A$  necessarily has a greater standard deviation than  $B$ .

(2) INSUFFICIENT: Statement (2) is insufficient since there are two different values of  $x$  less than 1 that give different answers to the question. For example, let  $x = 0$  so  $A = \{0, 1, 2\}$ . Then  $A$  has the same standard deviation as  $B$ .

Now let  $x = -100$ , so  $A = \{-100, 1, 2\}$ . Clearly  $A$  has a larger standard deviation than  $B$  since its data is much more spread out. Since we have found two different values of  $x$  that give different answers to the question, statement (2) is insufficient.

The correct answer is A.

14.

$10 - 0.3 = 9.7$   $10 + 0.3 = 10.3$  the number within 1 standard deviation should be between 9.7-10.3 so there are six numbers within 1 standard deviation  $6/8 = 75\%$

Answer is D

15.

1 and 2 standard deviations below the mean=>number of the hours at most is  $21-6=15$ , at least is  $21-2*6=9$ .

Answer is D

**16.**

For statement 1, we know that 68% are within  $[m-d, m+d]$ , so, the percent greater than  $m+d$  will be  $(1-0.68)/2$ .

For statement 2, we know that 16% is less than  $m-d$ , considering the distribution is symmetric about the mean  $m$ , we can get, 16% is greater than  $m+d$ .

Answer is D

# Inequalities + Absolute Value

1.

There are two characteristics of  $x$  that dictate its exponential behavior. First of all, it is a decimal with an absolute value of less than 1. Secondly, it is a negative number.

I. True.  $x^3$  will always be negative (negative  $\times$  negative  $\times$  negative = negative), and  $x^2$  will always be positive (negative  $\times$  negative = positive), so  $x^3$  will always be less than  $x^2$ .

II. True.  $x^5$  will always be negative, and since  $x$  is negative,  $1 - x$  will always be positive because the double negative will essentially turn  $1 - x$  into  $1 + |x|$ . Therefore,  $x^5$  will always be less than  $1 - x$ .

III. True. One useful method for evaluating this inequality is to plug in a number for  $x$ . If  $x = -0.5$ ,

$$x^4 = (-0.5)^4 = 0.0625$$

$$x^2 = (-0.5)^2 = 0.25$$

To understand why this works, it helps to think of the negative aspect of  $x$  and the decimal aspect of  $x$  separately.

Because  $x$  is being taken to an even exponent in both instances, we can essentially ignore the negative aspect because we know the both results will be positive.

The rule with decimals between 0 and 1 is that the number gets smaller and smaller in absolute value as the exponent gets bigger and bigger. Therefore,  $x^4$  must be smaller in absolute value than  $x^2$ .

The correct answer is E.

2.

(1) INSUFFICIENT: We can solve this absolute value inequality by considering both the positive and negative scenarios for the absolute value expression  $|x + 3|$ .

If  $x > -3$ , making  $(x + 3)$  positive, we can rewrite  $|x + 3|$  as  $x + 3$ :

$$x + 3 < 4$$

$$x < 1$$

If  $x < -3$ , making  $(x + 3)$  negative, we can rewrite  $|x + 3|$  as  $-(x + 3)$ :

$$-(x + 3) < 4$$

$$x + 3 > -4$$

$$x > -7$$

If we combine these two solutions we get  $-7 < x < 1$ , which means we can't tell whether  $x$  is positive.

(2) INSUFFICIENT: We can solve this absolute value inequality by considering both the positive and negative scenarios for the absolute value expression  $|x - 3|$ .

If  $x > 3$ , making  $(x - 3)$  positive, we can rewrite  $|x - 3|$  as  $x - 3$ :

$$x - 3 < 4$$

$$x < 7$$

If  $x < 3$ , making  $(x - 3)$  negative, we can rewrite  $|x - 3|$  as  $-(x - 3)$  OR  $3 - x$

$$3 - x < 4$$

$$x > -1$$

If we combine these two solutions we get  $-1 < x < 7$ , which means we can't tell whether  $x$  is positive.

(1) AND (2) INSUFFICIENT: If we combine the solutions from statements (1) and (2) we get an overlapping range of  $-1 < x < 7$ . We still can't tell whether  $x$  is positive.

The correct answer is E.

3.

The question asks: is  $x + n < 0$ ?

(1) INSUFFICIENT: This statement can be rewritten as  $x + n < 2n - 4$ . This rephrased statement is consistent with  $x + n$  being either negative or non-negative. (For example if  $2n - 4 = 1,000$ , then  $x + n$  could be any integer, negative or not, that is less than 1,000.) Statement (1) is insufficient because it answers our question by saying "maybe yes, maybe no".

(2) SUFFICIENT: We can divide both sides of this equation by  $-2$  to get  $x < -n$  (remember that the inequality sign flips when we multiply or divide by a negative number). After adding  $n$  to both sides of resulting inequality, we are left with  $x + n < 0$ .

The correct answer is B.

4.

This is a multiple variable inequality problem, so you must solve it by doing algebraic manipulations on the inequalities.

(1) INSUFFICIENT: Statement (1) relates  $b$  to  $d$ , while giving us no knowledge about  $a$  and  $c$ . Therefore statement (1) is insufficient.

(2) INSUFFICIENT: Statement (2) does give a relationship between  $a$  and  $c$ , but it still depends on the values of  $b$  and  $d$ . One way to see this clearly is by realizing that only the right side of the equation contains the variable  $d$ . Perhaps  $ab^2 - b$  is greater than  $b^2c - d$  simply because of the magnitude of  $d$ . Therefore there is no way to draw any conclusions about the relationship between  $a$  and  $c$ .

(1) AND (2) SUFFICIENT: By adding the two inequalities from statements (1) and (2) together, we can come to the conclusion that  $a > c$ . Two inequalities can always be added together as long as the direction of the inequality signs is the same:

$$ab^2 - b > b^2c - d$$

$$(+)\quad b > d$$

-----

$$ab^2 > b^2c$$

Now divide both sides by  $b^2$ . Since  $b^2$  is always positive, you don't have to worry about reversing the direction of the inequality. The final result:  $a > c$ .

The correct answer is C.

5.

Since this question is presented in a straightforward way, we can proceed right to the analysis of each statement. On any question that involves inequalities, make sure to simplify each inequality as much as possible before arriving at the final conclusion.

(1) INSUFFICIENT: Let's simplify the inequality to rephrase this statement:

$$-5x > -3x + 10$$

$$5x - 3x < -10 \quad (\text{don't forget: switch the sign when multiplying or dividing by a negative})$$

$$2x < -10$$

$$x < -5$$

Since this statement provides us only with a range of values for  $x$ , it is insufficient.

(2) INSUFFICIENT: Once again, simplify the inequality to rephrase the statement:

$$-11x - 10 < 67$$

$$-11x < 77$$

$$x > -7$$

Since this statement provides us only with a range of values for  $x$ , it is insufficient.

(1) AND (2) SUFFICIENT: If we combine the two statements together, it must be that  $-7 < x < -5$ . Since  $x$  is an integer,  $x = -6$ .

The correct answer is C.

6. We can start by solving the given inequality for  $x$ :

$$8x > 4 + 6x$$

$$2x > 4$$

$$x > 2$$

So, the rephrased question is: "If the integer  $x$  is greater than 2, what is the value of  $x$ ?"

(1) SUFFICIENT: Let's solve this inequality for  $x$  as well:

$$6 - 5x > -13$$

$$-5x > -19$$

$$x < 3.8$$

Since we know from the question that  $x > 2$ , we can conclude that  $2 < x < 3.8$ . The only integer between 2 and 3.8 is 3. Therefore,  $x = 3$ .

(2) SUFFICIENT: We can break this inequality into two distinct inequalities. Then, we can solve each inequality for  $x$ :

$$3 - 2x < -x + 4$$

$$3 - 4 < x$$

$$-1 < x$$

$$-x + 4 < 7.2 - 2x$$

$$x < 7.2 - 4$$

$$x < 3.2$$

So, we end up with  $-1 < x < 3.2$ . Since we know from the information given in the question that

$x > 2$ , we can conclude that  $2 < x < 3.2$ . The only integer between 2 and 3.2 is 3. Therefore,  $x = 3$ .

The correct answer is D.

7.

(1) INSUFFICIENT: The question asks us to compare  $a + b$  and  $c + d$ . No information is provided about  $b$  and  $d$ .

(2) INSUFFICIENT: The question asks us to compare  $a + b$  and  $c + d$ . No information is provided about  $a$  and  $c$ .

(1) AND (2) SUFFICIENT: If we rewrite the second statement as  $b > d$ , we can add the two inequalities:

$$\begin{array}{r} a > c \\ + \quad b > d \\ \hline \phantom{a} + d \end{array} \quad a + b > c$$

This can only be done when the two inequality symbols are facing the same direction. The correct answer is C.

8.

Let's start by rephrasing the question. If we square both sides of the equation we get:

$$\begin{aligned} (\sqrt{xy})^2 &= (xy)^2 \\ xy &= (xy)^2 \end{aligned}$$

Now subtract  $xy$  from both sides and factor:

$$\begin{aligned} (xy)^2 - xy &= 0 \\ xy(xy - 1) &= 0 \\ \text{So } xy &= 0 \text{ or } 1 \end{aligned}$$

To find the value of  $x + y$  here, we need to solve for both  $x$  and  $y$ .

If  $xy = 0$ , either  $x$  or  $y$  (or both) must be zero.

If  $xy = 1$ ,  $x$  and  $y$  are reciprocals of one another.

While we can't come up with a precise rephrasing here, the algebra we have done will help us see the usefulness of the statements.

(1) INSUFFICIENT: Knowing that  $x = -1/2$  does not tell us if  $y$  is 0 (i.e.  $xy = 0$ ) or if  $y$  is  $-2$  (i.e.  $xy = 1$ )

(2) INSUFFICIENT: Knowing that  $y$  is not equal to zero does not tell us anything about the value of  $x$ ;  $x$  could be zero (to make  $xy = 0$ ) or any other value (to make  $xy = 1$ ).

(1) AND (2) SUFFICIENT: If we know that  $y$  is not zero and we have a nonzero value for  $x$ , neither  $x$  nor  $y$  is zero;  $xy$  therefore must equal 1. If  $xy = 1$ , since  $x = -1/2$ ,  $y$  must equal  $-2$ . We can use this information to find  $x + y$ ,  $-1/2 + (-2) = -5/2$ .

The correct answer is C.

9.

The question asks whether  $x$  is greater than  $y$ . The question is already in its most basic form, so there is no need to rephrase it; we can go straight to the statements.

(1) INSUFFICIENT: The fact that  $x^2$  is greater than  $y$  does not tell us whether  $x$  is greater than  $y$ . For example, if  $x = 3$  and  $y = 4$ , then  $x^2 = 9$ , which is greater than  $y$  although  $x$  itself is less than  $y$ . But if  $x = 5$  and  $y = 4$ , then  $x^2 = 25$ , which is greater than  $y$  and  $x$  itself is also greater than  $y$ .

(2) INSUFFICIENT: We can square both sides to obtain  $x < y^2$ . As we saw in the examples above, it is possible for this statement to be true whether  $y$  is less than or greater than  $x$  (just substitute  $x$  for  $y$  and vice-versa in the examples above).

(1) AND (2) INSUFFICIENT: Taking the statements together, we know that  $x < y^2$  and  $y < x^2$ , but we do not know whether  $x > y$ . For example, if  $x = 3$  and  $y = 4$ , both of these inequalities hold ( $3 < 16$  and  $4 < 9$ ) and  $x < y$ . But if  $x = 4$  and  $y = 3$ , both of these inequalities still hold ( $4 < 9$  and  $3 < 16$ ) but now  $x > y$ .

The correct answer is E.

10.

The equation in question can be rephrased as follows:

$$x^2y - 6xy + 9y = 0$$

$$y(x^2 - 6x + 9) = 0$$

$$y(x - 3)^2 = 0$$

Therefore, one or both of the following must be true:

$$y = 0 \text{ or}$$

$$x = 3$$

It follows that the product  $xy$  must equal either 0 or  $3y$ . This question can therefore be rephrased "What is  $y$ ?"

(1) INSUFFICIENT: This equation cannot be manipulated or combined with the original equation to solve directly for  $x$  or  $y$ . Instead, plug the two possible scenarios from the original equation into the equation from this statement:

If  $x = 3$ , then  $y = 3 + x = 3 + 3 = 6$ , so  $xy = (3)(6) = 18$ .

If  $y = 0$ , then  $x = y - 3 = 0 - 3 = -3$ , so  $xy = (-3)(0) = 0$ .

Since there are two possible answers, this statement is not sufficient.

(2) SUFFICIENT: If  $x^3 < 0$ , then  $x < 0$ . Therefore,  $x$  cannot equal 3, and it follows that  $y = 0$ . Therefore,  $xy = 0$ .

The correct answer is B.

11.

(1) INSUFFICIENT: We can solve the quadratic equation by factoring:

$$x^2 - 5x + 6 = 0$$

$$(x - 2)(x - 3) = 0$$

$$x = 2 \text{ or } x = 3$$

Since there are two possible values for  $x$ , this statement on its own is insufficient.

(2) INSUFFICIENT: Simply knowing that  $x > 0$  is not enough to determine the value of  $x$ .

(1) AND (2) INSUFFICIENT: The two statements taken together still allow for two possible  $x$  values:  $x = 2$  or  $3$ .

The correct answer is E.

12.

This question is already in simple form and cannot be rephrased.

(1) INSUFFICIENT: This is a second-order or quadratic equation in standard form  $ax^2 + bx + c = 0$  where  $a = 1$ ,  $b = 3$ , and  $c = 2$ .

The first step in solving a quadratic equation is to reformat or "factor" the equation into a product of two factors of the form  $(x + y)(x + z)$ . The trick to factoring is to find two integers whose sum equals  $b$  and whose product equals  $c$ . (Informational note: the reason that this works is because multiplying out  $(x + y)(x + z)$  results in  $x^2 + (y + z)x + yz$ , hence  $y + z = b$  and  $yz = c$ ).

In this case, we have  $b = 3$  and  $c = 2$ . This is relatively easy to factor because  $c$  has only two possible combinations of integer multiples: 1 and 2; and -1 and -2. The only combination that also adds up to  $b$  is 1 and 2 since  $1 + 2 = 3$ . Hence, we can rewrite (1) as the product of two factors:  $(x + 1)(x + 2) = 0$ .

In order for a product to be equal to 0, it is only necessary for one of its factors to be equal to 0. Hence, to solve for  $x$ , we must find the  $x$ 's that would make either of the factors equal to zero.

The first factor is  $x + 1$ . We can quickly see that  $x + 1 = 0$  when  $x = -1$ . Similarly, the second factor  $x + 2$  is equal to zero when  $x = -2$ . Therefore,  $x$  can be either -1 or -2 and we do not have enough information to answer the question.

(2) INSUFFICIENT: We are given a range of possible values for  $x$ .

(1) and (2) INSUFFICIENT: (1) gives us two possible values for  $x$ , both of which are negative. (2) only tells us that  $x$  is negative, which does not help us pinpoint the value for  $x$ .

The correct answer is E.

13.

When solving an absolute value equation, it helps to first isolate the absolute value expression:

$$3|3 - x| = 7$$
$$|3 - x| = 7/3$$

When removing the absolute value bars, we need to keep in mind that the expression inside the absolute value bars  $(3 - x)$  could be positive or negative. Let's consider both possibilities:

When  $(3 - x)$  is positive:

$$(3 - x) = 7/3$$
$$3 - 7/3 = x$$
$$9/3 - 7/3 = x$$
$$x = 2/3$$

When  $(3 - x)$  is negative:

$$-(3 - x) = 7/3$$
$$x - 3 = 7/3$$
$$x = 7/3 + 3$$

$$x = 7/3 + 9/3$$
$$x = 16/3$$

So, the two possible values for  $x$  are  $2/3$  and  $16/3$ . The product of these values is  $32/9$ .

The correct answer is E.

14.

For their quotient to be less than zero,  $a$  and  $b$  must have opposite signs. In other words, if the answer to the question is "yes," EITHER  $a$  is positive and  $b$  is negative OR  $a$  is negative and  $b$  is positive.

The question can be rephrased as the following: "Do  $a$  and  $b$  have opposite signs?"

(1) INSUFFICIENT:  $a^2$  is always positive so for the quotient of  $a^2$  and  $b^3$  to be positive,  $b^3$  must be positive. That means that  $b$  is positive. This does not however tell us anything about the sign of  $a$ .

(2) INSUFFICIENT:  $b^4$  is always positive so for the product of  $a$  and  $b^4$  to be negative,  $a$  must be negative. This does not however tell us anything about the sign of  $b$ .

(1) AND (2) SUFFICIENT: Statement 1 tells us that  $b$  is positive and statement 2 tells us that  $a$  is negative. The yes/no question can be definitively answered with a "yes."

The correct answer is C.

15.

The question asks about the sign of  $d$ .

(1) INSUFFICIENT: When two numbers sum to a negative value, we have two possibilities:

Possibility A: Both values are negative (e.g.,  $e = -4$  and  $d = -8$ )

Possibility B: One value is negative and the other is positive.(e.g.,  $e = -15$  and  $d = 3$ ).

(2) INSUFFICIENT: When the difference of two numbers produces a negative value, we have three possibilities:

Possibility A: Both values are negative (e.g.,  $e = -20$  and  $d = -3$ )

Possibility B: One value is negative and the other is positive (e.g.,  $e = -20$  and  $d = 3$ ).

Possibility C: Both values are positive (e.g.,  $e = 20$  and  $d = 30$ )

(1) AND (2) SUFFICIENT: When  $d$  is ADDED to  $e$ , the result ( $-12$ ) is greater than when  $d$  is SUBTRACTED from  $e$ . This is only possible if  $d$  is a positive value. If  $d$  were a negative value than adding  $d$  to a number would produce a smaller value than subtracting  $d$  from that number (since a double negative produces a positive). You can test numbers to see that  $d$  must be positive and so we can definitively answer the question using both statements.

16.

We are given the inequality  $a - b > a + b$ . If we subtract  $a$  from both sides, we are left with the inequality  $-b > b$ . If we add  $b$  to both sides, we get  $0 > 2b$ . If we divide both sides by 2, we can rephrase the given information as  $0 > b$ , or  $b$  is negative.

I. FALSE: All we know from the given inequality is that  $0 > b$ . The value of  $a$  could be either positive or negative.

II. TRUE: We know from the given inequality that  $0 > b$ . Therefore,  $b$  must be negative.

III. FALSE: We know from the given inequality that  $0 > b$ . Therefore,  $b$  must be negative. However, the value of  $a$  could be either positive or negative. Therefore,  $ab$  could be positive or negative.

The correct answer is B.

17.

Given that  $|a| = 1/3$ , the value of  $a$  could be either  $1/3$  or  $-1/3$ . Likewise,  $b$  could be either  $2/3$  or  $-2/3$ . Therefore, four possible solutions to  $a + b$  exist, as shown in the following table:

$a$	$b$	$a + b$
$1/3$	$2/3$	$1$
$1/3$	$-2/3$	$-1/3$
$-1/3$	$2/3$	$1/3$
$-1/3$	$-2/3$	$-1$

$2/3$  is the only answer choice that does not represent a possible sum of  $a + b$ .

The correct answer is D.

18.

Because we know that  $|a| = |b|$ , we know that  $a$  and  $b$  are equidistant from zero on the number line. But we do not know anything about the signs of  $a$  and  $b$  (that is, whether they are positive or negative). Because the question asks us which statement(s) MUST be true, we can eliminate any statement that is not always true. To prove that a statement is not always true, we need to find values for  $a$  and  $b$  for which the statement is false.

I. NOT ALWAYS TRUE:  $a$  does not necessarily have to equal  $b$ . For example, if  $a = -3$  and  $b = 3$ , then  $|-3| = |3|$  but  $-3 \neq 3$ .

II. NOT ALWAYS TRUE:  $|a|$  does not necessarily have to equal  $-b$ . For example, if  $a = 3$  and  $b = 3$ , then  $|3| = |3|$  but  $|3| \neq -3$ .

III. NOT ALWAYS TRUE:  $-a$  does not necessarily have to equal  $-b$ . For example, if  $a = -3$  and  $b = 3$ , then  $|-3| = |3|$  but  $-(-3) \neq -3$ .

The correct answer is E.

19.

Let us start by examining the conditions necessary for  $|a|b > 0$ . Since  $|a|$  cannot be negative, both  $|a|$  and  $b$  must be positive. However, since  $|a|$  is positive whether  $a$  is negative or positive, the only condition for  $a$  is that it must be non-zero.

Hence, the question can be restated in terms of the necessary conditions for it to be answered "yes":

**"Do both of the following conditions exist:  $a$  is non-zero AND  $b$  is positive?"**

(1) INSUFFICIENT: In order for  $a = 0$ ,  $|a|^b$  would have to equal 0 since 0 raised to any power is always 0. Therefore (1) implies that  $a$  is non-zero. However, given that  $a$  is non-zero,  $b$  can be *anything* for  $|a|^b > 0$  so we cannot determine the sign of  $b$ .

(2) INSUFFICIENT: If  $a = 0$ ,  $|a| = 0$ , and  $|a|^b = 0$  for any  $b$ . Hence,  $a$  must be non-zero and the first condition ( $a$  is not equal to 0) of the restated question is met. We now need to test whether the second condition is met. (Note: If  $a$  had been zero, we would have been able to conclude right away that (2) is sufficient because we would answer "no" to the question is  $|a|b > 0$ ?) Given that  $a$  is non-zero,  $|a|$  must be positive integer. At first glance, it seems that  $b$  must be positive because a positive integer raised to a negative integer is typically fractional (e.g.,  $a^{-2} = 1/a^2$ ). Hence, it appears that  $b$  cannot be negative. However, there is a special case where this is not so:

If  $|a| = 1$ , then  $b$  could be anything (positive, negative, or zero) since  $|1|^b$  is always equal to 1, which is a non-zero integer. In addition, there is also the possibility that  $b = 0$ . If  $|b| = 0$ , then  $|a|^0$  is always 1, which is a non-zero integer.

Hence, based on (2) alone, we cannot determine whether  $b$  is positive and we cannot answer the question.

An alternative way to analyze this (or to confirm the above) is to create a chart using simple numbers as follows:

$a$	$B$	Is $ a ^b$ a non-zero integer?	Is $ a/b  > 0$ ?
1	2	Yes	Yes
1	-2	Yes	No
2	1	Yes	Yes
2	0	Yes	No

We can quickly confirm that (2) alone does not provide enough information to answer the question.

(1) AND (2) INSUFFICIENT: The analysis for (2) shows that (2) is insufficient because, while we can conclude that  $a$  is non-zero, we cannot determine whether  $b$  is positive. (1) also implies that  $a$  is non-zero, but does not provide any information about  $b$  other than that it could be anything. Consequently, (1) does not add any information to (2) regarding  $b$  to help answer the question and (1) and (2) together are still insufficient. (Note: As a quick check, the above chart can also be used to analyze (1) and (2) together since all of the values in column 1 are also consistent with (1)).

20.

The question asks whether  $x^n$  is less than 1. In order to answer this, we need to know not only whether  $x$  is less than 1, but also whether  $n$  is positive or negative since it is the combination of the two conditions that determines whether  $x^n$  is less than 1.

(1) INSUFFICIENT: If  $x = 2$  and  $n = 2$ ,  $x^n = 2^2 = 4$ . If  $x = 2$  and  $n = -2$ ,  $x^n = 2^{(-2)} = 1/(2^2) = 1/4$ .

(2) INSUFFICIENT: If  $x = 2$  and  $n = 2$ ,  $x^n = 2^2 = 4$ . If  $x = 1/2$  and  $n = 2$ ,  $x^n = (1/2)^2 = 1/4$ .

(1) AND (2) SUFFICIENT: Taken together, the statements tell us that  $x$  is greater than 1 and  $n$  is positive. Therefore, for any value of  $x$  and for any value of  $n$ ,  $x^n$  will be greater than 1 and we can answer definitively "no" to the question.

The correct answer is C.

21.

Since  $3^5 = 243$  and  $3^6 = 729$ ,  $3x$  will be less than 500 only if the integer  $x$  is less than 6. So, we can rephrase the question as follows: "Is  $x < 6$ ?"

(1) INSUFFICIENT: We can solve the inequality for  $x$ .

$$4^{x-1} < 4^x - 120$$

$$4^{x-1} - 4^x < -120$$

$$4^x(4^{-1}) - 4^x < -120$$

$$4^x(1/4) - 4^x < -120$$

$$4^x[(1/4) - 1] < -120$$

$$4^x(-3/4) < -120$$

$$4^x > 160$$

Since  $4^3 = 64$  and  $4^4 = 256$ ,  $x$  must be greater than 3. However, this is not enough to determine if  $x < 6$ .

(2) INSUFFICIENT: If  $x^2 = 36$ , then  $x = 6$  or  $-6$ . Again, this is not enough to determine if  $x < 6$ .

(1) AND (2) SUFFICIENT: Statement (1) tells us that  $x > 3$  and statement (2) tells us that  $x = 6$  or  $-6$ . Therefore, we can conclude that  $x = 6$ . This is sufficient to answer the question "Is  $x < 6$ ?" (Recall that the answer "no" is sufficient.)

The correct answer is C

22.

Remember that an odd exponent does not "hide the sign," meaning that  $x$  must be positive in order for  $x^3$  to be positive. So, the original question "Is  $x^3 > 1$ ?" can be rephrased "Is  $x > 1$ ?"

(1) INSUFFICIENT: It is not clear whether  $x$  is greater than 1. For example,  $x$  could be  $-1$ , and the answer to the question would be "no," since  $(-1)^3 = -1 < 1$ . However,  $x$  could be  $2$ , and the answer to the question would be "yes," since  $2^3 = 8 > 1$ .

(2) SUFFICIENT: First, simplify the statement as much as possible.

$$2x - (b - c) < c - (b - 2)$$

$$2x - b + c < c - b + 2 \quad [\text{Distributing the subtraction sign on both sides}]$$

$$2x < 2 \quad [\text{Canceling the identical terms } (+c \text{ and } -b) \text{ on each side}]$$

$$x < 1 \quad [\text{Dividing both sides by 2}]$$

Thus, the answer to the rephrased question "Is  $x > 1$ ?" is always "no." Remember that for "yes/no" data sufficiency questions it doesn't matter whether the answer is "yes" or "no"; what is important is whether the additional information is sufficient to answer either *definitively* "yes" or *definitively* "no." In this case, given the information in (2), the answer is always "no"; therefore, the answer is a definitive "no" and (2) is sufficient to answer the question. If the answer were "yes" for some values of  $x$  and "no" for other values of  $x$ , it would not be possible to answer the question definitively, and (2) would not be sufficient.

The correct answer is B.

23.

Square both sides of the given equation to eliminate the square root sign:

$$(x + 4)^2 = 9$$

Remember that even exponents "hide the sign" of the base, so there are two solutions to the equation:  $(x + 4) = 3$  or  $(x + 4) = -3$ . On the GMAT, the negative solution is often the correct one, so evaluate that one first.

$$(x + 4) = -3$$

$$x = -3 - 4$$

$$x = -7$$

Watch out! Although  $-7$  is an answer choice, it is not correct. The question does not ask for the

value of  $x$ , but rather for the value of  $x - 4 = -7 - 4 = -11$ .

Alternatively, the expression  $\sqrt{(x + 4)^2}$  can be simplified to  $|x + 4|$ , and the original equation can be solved accordingly.

If  $|x + 4| = 3$ , either  $x = -1$  or  $x = -7$

The correct answer is A.

24.

(1) SUFFICIENT: Statement (1) tells us that  $x > 2^{34}$ , so we want to prove that  $2^{34} > 10^{10}$ . We'll prove this by manipulating the expression  $2^{34}$ .

$$2^{34} = (2^4)(2^{30})$$

$$2^{34} = 16(2^{10})^3$$

Now  $2^{10} = 1024$ , and 1024 is greater than  $10^3$ . Therefore:

$$2^{34} > 16(10^3)^3$$

$$2^{34} > 16(10^9)$$

$$2^{34} > 1.6(10^{10}).$$

Since  $2^{34} > 1.6(10^{10})$  and  $1.6(10^{10}) > 10^{10}$ , then  $2^{34} > 10^{10}$ .

(2) SUFFICIENT: Statement (2) tells us that  $x = 2^{35}$ , so we need to determine if  $2^{35} > 10^{10}$ . Statement (1) showed that  $2^{34} > 10^{10}$ , therefore  $2^{35} > 10^{10}$ .

The correct answer is D.

**25.**

$$X - 2Y < -6 \Rightarrow -X + 2Y > 6$$

Combined  $X - Y > -2$ , we know  $Y > 4$

$$X - Y > -2 \Rightarrow -2X + 2Y < 4$$

Combined  $X - 2Y < -6$ , we know  $-X < -2 \Rightarrow X > 2$

Therefore,  $XY > 0$

Answer is C

26. The rules of odds and evens tell us that the product will be odd if all the factors are odd, and the product will be even if at least one of the factors is even. In order to analyze the given statements I, II, and III, we must determine whether  $x$  and  $y$  are odd or even. First, solve the absolute value equation for  $x$  by considering both the positive and negative values of the absolute value expression.

If  $|x - 9/2| = 5$ ,  $x = 7$  or  $2$ . Therefore,  $x$  can be either odd or even.

Next, consider the median ( $y$ ) of a set of  $p$  consecutive integers, where  $p$  is odd. Will this median necessarily be odd or even? Let's choose two examples to find out:

Example Set 1: 1, 2, 3 (the median  $y = 2$ , so  $y$  is even)

Example Set 2: 3, 4, 5, 6, 7 (the median  $y = 5$ , so  $y$  is odd)

Therefore,  $y$  can be either odd or even.

Now, analyze the given statements:

I. UNCERTAIN: Statement I will be true if and only if  $x$ ,  $y$ , and  $p$  are all odd. We know  $p$  is odd, but since  $x$  and  $y$  can be either odd or even we cannot definitively say that  $xyp$  will be odd. For example, if  $x = 2$  then  $xyp$  will be even.

II. TRUE: Statement II will be true if any one of the factors is even. After factoring out a  $p$ , the expression can be written as  $xyp(p + 1)$ . Since  $p$  is odd, we know  $(p + 1)$  must be even. Therefore, the product of  $xyp(p + 1)$  must be even.

III. UNCERTAIN: Statement III will be true if any one of the factors is even. The expression can be written as  $xyyp$ . We know that  $p$  is odd, and we also know that both  $x$  and  $y$  could be odd.

The correct answer is A.

27. The  $|x| + |y|$  on the left side of the equation will always add the positive value of  $x$  to the positive value of  $y$ , yielding a positive value. Therefore, the  $-x$  and the  $-y$  on the right side of the equation must also each yield a positive value. The only way for  $-x$  and  $-y$  to each yield positive values is if both  $x$  and  $y$  are negative.

(A) FALSE: For  $x + y$  to be greater than zero, either  $x$  or  $y$  has to be positive.

(B) TRUE: Since  $x$  has to be negative and  $y$  has to be negative, the sum of  $x$  and  $y$  will always be negative.

(C) UNCERTAIN: All that is certain is that  $x$  and  $y$  have to be negative. Since  $x$  can have a larger magnitude than  $y$  and vice-versa,  $x - y$  could be greater than zero.

(D) UNCERTAIN: All that is certain is that  $x$  and  $y$  have to be negative. Since  $x$  can have a larger magnitude than  $y$  and vice versa,  $x - y$  could be less than zero.

(E) UNCERTAIN: As with choices (C) and (D), we have no idea about the magnitude of  $x$  and  $y$ . Therefore,  $x^2 - y^2$  could be either positive or negative.

Another option to solve this problem is to systematically test numbers. With values for  $x$  and  $y$  that satisfy the original equation, observe that both  $x$  and  $y$  have to be negative. If

$x = -4$  and  $y = -2$ , we can eliminate choices (A) and (C). Then, we might choose numbers such that  $y$  has a greater magnitude than  $x$ , such as  $x = -2$  and  $y = -4$ . With these values, we can eliminate choices (D) and (E).

The correct answer is B.

28. The question asks if  $xy < 0$ . Knowing the rules for positives and negatives (the product of two numbers will be positive if the numbers have the same sign and negative if the numbers have different signs), we can rephrase the question as follows: Do  $x$  and  $y$  have the same sign?

(1) INSUFFICIENT: We can factor the right side of the equation  $y = x^4 - x^3$  as follows:

$$y = x^4 - x^3$$
$$y = x^3(x - 1)$$

Let's consider two cases: when  $x$  is negative and when  $x$  is positive. When  $x$  is negative,  $x^3$  will be negative (a negative integer raised to an odd exponent results in a negative), and  $(x - 1)$  will be negative. Thus,  $y$  will be the product of two negatives, giving a positive value for  $y$ .

When  $x$  is positive,  $x^3$  will be positive and  $(x - 1)$  will be positive (remember that the question includes the constraint that  $xy$  is not equal to 0, which means  $y$  cannot be 0, which in turn means that  $x$  cannot be 1). Thus,  $y$  will be the product of two positives, giving a positive value for  $y$ .

In both cases,  $y$  is positive. However, we don't have enough information to determine the sign of  $x$ . Therefore, this statement alone is insufficient.

(2) INSUFFICIENT: Let's factor the left side of the given inequality:

$$\begin{aligned} -12y^2 - y^2x + x^2y^2 &> 0 \\ y^2(-12 - x + x^2) &> 0 \\ y^2(x^2 - x - 12) &> 0 \\ y^2(x + 3)(x - 4) &> 0 \end{aligned}$$

The expression  $y^2$  will obviously be positive, but it tells us nothing about the sign of  $y$ ; it could be positive or negative. Since  $y$  does not appear anywhere else in the inequality, we can conclude that statement 2 alone is insufficient (without determining anything about  $x$ ) because the statement tells us nothing about  $y$ .

(1) AND (2) INSUFFICIENT: We know from statement (1) that  $y$  is positive; we now need to examine statement 2 further to see what we can determine about  $x$ .

We previously determined that  $y^2(x + 3)(x - 4) > 0$ . Thus, in order for  $y^2(x + 3)(x - 4)$  to be greater than 0,  $(x + 3)$  and  $(x - 4)$  must have the same sign. There are two ways for this to happen: both  $(x + 3)$  and  $(x - 4)$  are positive, or both  $(x + 3)$  and  $(x - 4)$  are negative. Let's look at the positive case first.

$$\begin{aligned} x + 3 &> 0 \\ x &> -3, \text{ and} \end{aligned}$$

$$\begin{aligned} x - 4 &> 0 \\ x &> 4 \end{aligned}$$

So, for both expressions to be positive,  $x$  must be greater than 4. Now let's look at the negative case:

$$\begin{aligned} x + 3 &< 0 \\ x &< -3, \text{ and} \end{aligned}$$

$$\begin{aligned} x - 4 &< 0 \\ x &< 4 \end{aligned}$$

For both expressions to be negative,  $x$  must be less than -3. In conclusion, statement (2) tells us that  $x > 4$  OR  $x < -3$ . This is obviously not enough to determine the sign of  $x$ . Since the sign of  $x$  is still unknown, the combination of statements is insufficient to answer the question "Do  $x$  and  $y$  have the same sign?"

The correct answer is E.

29. This question cannot be rephrased since it is already in a simple form.

(1) INSUFFICIENT: Since  $x^2$  is positive whether  $x$  is negative or positive, we can only determine that  $x$  is not equal to zero;  $x$  could be either positive or negative.

(2) INSUFFICIENT: By telling us that the expression  $x \cdot |y|$  is not a positive number, we know that it must either be negative or zero. If the expression is negative,  $x$  must be negative ( $|y|$  is never negative). However if the expression is zero,  $x$  or  $y$  could be zero.

(1) AND (2) INSUFFICIENT: We know from statement 1 that  $x$  cannot be zero, however, there are still two possibilities for  $x$ :  $x$  could be positive ( $y$  is zero), or  $x$  could be negative ( $y$  is anything).

The correct answer is E.

30. First, let's try to make some inferences from the fact that  $ab^2c^3d^4 > 0$ . Since none of the integers is equal to zero (their product does not equal zero),  $b$  and  $d$  raised to even exponents must be positive, i.e.  $b^2 > 0$  and  $d^4 > 0$ , implying that  $b^2d^4 > 0$ . If  $b^2d^4 > 0$  and  $ab^2c^3d^4 > 0$ , the product of the remaining variables,  $a$  and  $c^3$  must be positive, i.e.  $ac^3 > 0$ . As a result, while we do not know the specific signs of any variable, we know that  $ac > 0$  (because the odd exponent  $c^3$  will always have the same sign as  $c$ ) and therefore  $a$  and  $c$  must have the same sign—either both positive or both negative.

Next, let's evaluate each of the statements:

**I. UNCERTAIN:** While we know that the even exponent  $a^2$  must be positive, we do not know anything about the signs of the two remaining variables,  $c$  and  $d$ . If  $c$  and  $d$  have the same signs, then  $cd > 0$  and  $a^2cd > 0$ , but if  $c$  and  $d$  have different signs, then  $cd < 0$  and  $a^2cd < 0$ .

**II. UNCERTAIN:** While we know that the even exponent  $c^4$  must be positive, we do not know anything about the signs of the two remaining variables,  $b$  and  $d$ . If  $b$  and  $d$  have the same signs, then  $bd > 0$  and  $bc^4d > 0$ , but if  $b$  and  $d$  have different signs, then  $bd < 0$  and  $bc^4d < 0$ .

**III. TRUE:** Since  $a^3c^3 = (ac)^3$  and  $a$  and  $c$  have the same signs, it must be true that  $ac > 0$  and  $(ac)^3 > 0$ . Also, the even exponent  $d^2$  will be positive. As a result, it must be true that  $a^3c^3d^2 > 0$ .

The correct answer is C.

31. It is extremely tempting to divide both sides of this inequality by  $y$  or by the  $|y|$ , to come up with a rephrased question of "is  $x > y^2$ ?" However, we do not know the sign of  $y$ , so this cannot be done.

(1) INSUFFICIENT: On a yes/no data sufficiency question that deals with number properties (positive/negatives), it is often easier to plug numbers. There are two good reasons why we should try both positive and negative values for  $y$ : (1) the question contains the expression  $|y|$ , (2) statement 2 hints that the sign of  $y$  might be significant. If we do that we come up with both a yes and a no to the question.

$x$	$y$	$x \cdot  y  > y^2$	?
-2	-4	$-2(4) > (-4)^2$	N
4	2	$4(2) > 2^2$	Y

(2) INSUFFICIENT: Using the logic from above, when trying numbers here we should take care to pick  $x$  values that are both greater than  $y$  and less than  $y$ .

$x$	$y$	$x \cdot  y  > y^2$	?
2	4	$2(4) > 4^2$	N
4	2	$4(2) > 2^2$	Y

(1) AND (2) SUFFICIENT: If we combine the two statements, we must choose positive  $x$  and  $y$  values for which  $x > y$ .

$x$	$y$	$x \cdot  y  > y^2$	?
3	1	$3(1) > 1^2$	Y
4	2	$4(2) > 2^2$	Y
5	3	$5(3) > 3^2$	Y

Using a more algebraic approach, if we know that  $y$  is positive (statement 2), we can divide both sides of the original question by  $y$  to

come up with "is  $x > y$ ?" as a new question. Statement 1 tells us that  $x > y$ , so both statements together are sufficient to answer the question.

The correct answer is C.

32. (1) INSUFFICIENT: This expression provides only a range of possible values for  $x$ .

(2) SUFFICIENT: Absolute value problems often -- **but not always** -- have multiple solutions because the expression *within* the absolute value bars can be either positive or negative even though the absolute value of the expression is always positive. For example, if we consider the equation  $|2 + x| = 3$ , we have to consider the possibility that  $2 + x$  is already positive and the possibility that  $2 + x$  is negative. If  $2 + x$  is positive, then the equation is the same as  $2 + x = 3$  and  $x = 1$ . But if  $2 + x$  is negative, then it must equal  $-3$  (since  $|-3| = 3$ ) and so  $2 + x = -3$  and  $x = -5$ .

So in the present case, in order to determine the possible solutions for  $x$ , it is necessary to solve for  $x$  under both possible conditions.

For the case where  $x > 0$ :

$$\begin{aligned} x &= 3x - 2 \\ -2x &= -2 \\ x &= 1 \end{aligned}$$

For the case when  $x < 0$ :

$$\begin{aligned} x &= -1(3x - 2) \text{ We multiply by } -1 \text{ to make } x \text{ equal a negative quantity.} \\ x &= 2 - 3x \\ 4x &= 2 \\ x &= 1/2 \end{aligned}$$

Note however, that the second solution  $x = 1/2$  contradicts the stipulation that  $x < 0$ , hence there is no solution for  $x$  where  $x < 0$ . Therefore,  $x = 1$  is the only valid solution for (2).

The correct answer is B.

33. (1) INSUFFICIENT: If we test values here we find two sets of possible  $x$  and  $y$  values that yield conflicting answers to the question.

$x$	$\sqrt{x}$	$y$	Is $x > y$ ?
4	2	1	YES
1/4	1/2	1/3	NO

- (2) INSUFFICIENT: If we test values here we find two sets of possible  $x$  and  $y$  values that yield conflicting answers to the question.

$x$	$x^3$	$y$	Is $x > y$ ?
2	8	1	YES
-1/2	-1/8	-1/4	NO

- (1) AND (2) SUFFICIENT: Let's start with statement 1 and add the constraints of statement 2. From statement 1, we see that  $x$  has to be positive since we are taking the square root of  $x$ . There is no point in testing negative values for  $y$  since a positive value for  $x$  against a negative  $y$  will always yield a yes to the question. Lastly, we should consider  $x$  values between 0 and 1 and greater than 1 because proper fractions behave different than integers with regard to exponents. When we try to come up with  $x$  and  $y$  values that fit both conditions, we must adjust the two variables so that  $x$  is always greater than  $y$ .

$x$	$\sqrt{x}$	$x^3$	$y$	Is $x > y$ ?
2	1.4	8	1	YES
1/4	1/2	1/64	1/128	YES

Logically it also makes sense that if the cube and the square root of a number are both greater than another number then the number itself must be greater than that other number.

The correct answer is C.

34. The question "Is  $|x|$  less than 1?" can be rephrased in the following way.

Case 1: If  $x > 0$ , then  $|x| = x$ . For instance,  $|5| = 5$ . So, if  $x > 0$ , then the question becomes "Is  $x$  less than 1?"

Case 2: If  $x < 0$ , then  $|x| = -x$ . For instance,  $|-5| = -(-5) = 5$ . So, if  $x < 0$ , then the question becomes "Is  $-x$  less than 1?" This can be written as follows:

$$-x < 1?$$

or, by multiplying both sides by  $-1$ , we get

$$x > -1?$$

Putting these two cases together, we get the fully rephrased question:  
 "Is  $-1 < x < 1$  (and  $x$  not equal to 0)?"

Another way to achieve this rephrasing is to interpret absolute value as distance from zero on the number line. Asking "Is  $|x|$  less than 1?" can then be reinterpreted as "Is  $x$  less than 1 unit away from zero on the number line?" or "Is  $-1 < x < 1$ ?" (The fact that  $x$  does not equal zero is given in the question stem.)

(1) INSUFFICIENT: If  $x > 0$ , this statement tells us that  $x > x/x$  or  $x > 1$ . If  $x < 0$ , this statement tells us that  $x > x/-x$  or  $x > -1$ . This is not enough to tell us if  $-1 < x < 1$ .

(2) INSUFFICIENT: When  $x > 0$ ,  $x > x$  which is not true (so  $x < 0$ ). When  $x < 0$ ,  $-x > x$  or  $x < 0$ . Statement (2) simply tells us that  $x$  is negative. This is not enough to tell us if  $-1 < x < 1$ .

(1) AND (2) SUFFICIENT: If we know  $x < 0$  (statement 2), we know that  $x > -1$  (statement 1). This means that  $-1 < x < 0$ . This means that  $x$  is definitely between  $-1$  and  $1$ .

The correct answer is C.

35. (1) SUFFICIENT: We can combine the given inequality  $r + s > 2t$  with the first statement by adding the two inequalities:

$$\begin{array}{r} r + s > 2t \\ \underline{t > s} \\ r + s + t > 2t + s \\ r > t \end{array}$$

(2) SUFFICIENT: We can combine the given inequality  $r + s > 2t$  with the second statement by adding the two inequalities:

$$\begin{array}{r} r + s > 2t \\ \underline{r > s} \\ 2r + s > 2t + s \\ 2r > 2t \\ r > t \end{array}$$

The correct answer is D.

36. The question stem gives us three constraints:

- 1)  $a$  is an integer.
- 2)  $b$  is an integer.
- 3)  $a$  is farther away from zero than  $b$  is (from the constraint that  $|a| > |b|$ ).

When you see a problem using absolute values, it is generally necessary to try positive and negative values for each of the variables. Thus, we should take the information from the question, and see what it tells us about the signs of the variables.

For  $b$ , we should try negative, zero, and positive values. Nothing in the question stem eliminates any of those possibilities. For  $a$ , we only have to try negative and positive values. Why not  $a = 0$ ? We know that  $b$  must be closer to zero than  $a$ , so  $a$  cannot equal zero because there is no potential value for  $b$  that is closer to zero than zero itself. So to summarize, the possible scenarios are:

$a$	$b$
neg	neg
neg	0
neg	pos
pos	neg
pos	0
pos	pos

(1) INSUFFICIENT: This statement tells us that  $a$  is negative, ruling out the positive  $a$  scenarios above. Remember that  $a$  is farther away from zero than  $b$  is.

$a$	$b$	$a \cdot  b $	$a - b$	Is $a \cdot  b  < a - b$ ?
neg	neg	$\text{neg} \cdot  \text{neg} $ $= \text{neg} \cdot \text{pos}$ $= \text{more negative}$	$\text{neg (far from 0)} - \text{neg (close to 0)}$ $= \text{neg (far from 0)} + \text{pos (close to 0)}$ $= \text{less neg}$	Is more neg < less neg? <b>Yes.</b>
neg	0	$\text{neg} \cdot  0  = \text{neg} \cdot 0 = 0$	$\text{neg} - 0 = \text{neg}$	Is $0 < \text{neg}$ ? <b>No.</b>
neg	pos	$\text{neg} \cdot  \text{pos} $ $= \text{neg} \cdot \text{pos}$ $= \text{at least as negative as } a, \text{ since } b \text{ could be 1 or greater}$	$\text{neg} - \text{pos}$ $= \text{more negative than } a$	Is at least as negative as $a <$ more negative than $a$ ? <b>It depends.</b>

For some cases the answer is "yes," but for others the answer is "no." Therefore, statement (1) is insufficient to solve the problem.

(2) INSUFFICIENT: This statement tells us that  $a$  and  $b$  must either have the same sign (for  $ab > 0$ ), or one or both of the variables must be zero (for  $ab = 0$ ). Thus we can rule out any scenario in the original list that doesn't meet the constraints from this statement.

$a$	$B$	$a \cdot  b $	$a - b$	Is $a \cdot  b  < a - b$ ?
neg	neg	$\text{neg} \cdot  \text{neg} $ $= \text{neg} \cdot \text{pos}$ $= \text{more negative}$	$\text{neg (far from 0)} - \text{neg (close to 0)}$ $= \text{neg (far from 0)} + \text{pos (close to 0)}$ $= \text{less negative}$	Is more negative < less negative? <b>Yes.</b>
neg	0	$\text{neg} \cdot  0  = 0$	$\text{neg} - 0 = \text{neg}$	Is $0 < \text{neg}$ ? <b>No.</b>
pos	0	$\text{pos} \cdot  0  = 0$	$\text{pos} - 0 = \text{pos}$	Is $0 < \text{pos}$ ? <b>Yes.</b>
pos	pos	$\text{pos} \cdot  \text{pos} $ $= \text{more positive}$	$\text{pos (far from 0)} - \text{pos (close to 0)}$ $= \text{less positive}$	Is more positive < less positive? <b>No.</b>

For some cases the answer is "yes," but for others the answer is "no." Therefore, statement (2) is insufficient to solve the problem.

(1) & (2) INSUFFICIENT: For the two statements combined, we must consider only the scenarios with negative  $a$  and either negative or zero  $b$ . These are the scenarios that are on the list for both statement (1) and statement (2).

$a$	$B$	$a \cdot  b $	$a - b$	Is $a \cdot  b  < a - b$ ?
-----	-----	---------------	---------	----------------------------

neg	neg	neg ·  neg  = neg · pos = more negative	neg (far from 0) - neg (close to 0) = neg (far from 0) + pos (close to 0) = less negative	Is more negative < less negative? <b>Yes</b>
neg	0	neg ·  0  = 0	neg - 0 = neg	Is 0 < neg? <b>No</b>

For the first case the answer is "yes," but for the second case the answer is "no." Thus the two statements combined are not sufficient to solve the problem.

The correct answer is E.

37. This is a multiple variable inequality problem, so you must solve it by doing algebraic manipulations on the inequalities.

(1) INSUFFICIENT: Statement (1) relates  $b$  to  $d$ , while giving us no knowledge about  $a$  and  $c$ . Therefore statement (1) is insufficient.

(2) INSUFFICIENT: Statement (2) does give a relationship between  $a$  and  $c$ , but it still depends on the values of  $b$  and  $d$ . One way to see this clearly is by realizing that only the right side of the equation contains the variable  $d$ . Perhaps  $ab^2 - b$  is greater than  $b^2c - d$  simply because of the magnitude of  $d$ . Therefore there is no way to draw any conclusions about the relationship between  $a$  and  $c$ .

(1) AND (2) SUFFICIENT: By adding the two inequalities from statements (1) and (2) together, we can come to the conclusion that  $a > c$ . Two inequalities can always be added together as long as the direction of the inequality signs is the same:

$$\begin{array}{r}
 ab^2 - b > b^2c - d \\
 (+) \quad b > d \\
 \hline
 ab^2 > b^2c
 \end{array}$$

Now divide both sides by  $b^2$ . Since  $b^2$  is always positive, you don't have to worry about reversing the direction of the inequality. The final result:  $a > c$ .

The correct answer is C.

- 38.

The question tells us that  $p < q$  and  $p < r$  and then asks whether the product  $pqr$  is less than  $p$ . Statement (1) INSUFFICIENT: We learn from this statement that either  $p$  or  $q$  is negative, but since we know from the question that  $p < q$ ,  $p$  must be negative. To determine whether  $pqr < p$ , let's test values for  $p$ ,  $q$ , and  $r$ . Our test values must meet only 2 conditions:  $p$  must be negative and  $q$  must be positive.

$p$	$q$	$r$	$pqr$	Is $pqr < p$ ?
-2	5	10	-100	YES
-2	5	-10	100	NO

Statement (2) INSUFFICIENT: We learn from this statement that either  $p$  or  $r$  is negative, but since we know from the question that  $p < r$ ,  $p$  must be negative. To determine whether  $pqr < p$ , let's test values for  $p$ ,  $q$ , and  $r$ . Our test values must meet only 2 conditions:  $p$  must be negative and  $r$  must be positive.

$p$	$q$	$r$	$pqr$	Is $pqr < p$ ?
-2	-10	5	100	NO

-2	10	5	-100	YES
----	----	---	------	-----

If we look at both statements together, we know that  $p$  is negative and that both  $q$  and  $r$  are positive. To determine whether  $pqr < p$ , let's test values for  $p$ ,  $q$ , and  $r$ . Our test values must meet 3 conditions:  $p$  must be negative,  $q$  must be positive, and  $r$  must be positive.

$p$	$q$	$r$	$pqr$	Is $pqr < p$ ?
-2	10	5	-100	YES
-2	7	4	-56	YES

At first glance, it may appear that we will always get a "YES" answer. But don't forget to test out fractional (decimal) values as well. The problem never specifies that  $p$ ,  $q$ , and  $r$  must be integers.

$p$	$q$	$r$	$pqr$	Is $pqr < p$ ?
-2	.3	.4	-.24	NO

Even with both statements, we cannot answer the question definitively. The correct answer is E.

39. We are told that  $|x| \cdot y + 9 > 0$ , which means that  $|x| \cdot y > -9$ . The question asks whether  $x < 6$ . A statement counts as sufficient if it enables us to answer the question with "definitely yes" or "definitely no"; a statement that only enables us to say "maybe" counts as insufficient.

- (1) INSUFFICIENT: We know that  $|x| \cdot y > -9$  and that  $y$  is a negative integer. Suppose  $y = -1$ . Then  $|x| \cdot (-1) > -9$ , which means  $|x| < 9$  (since dividing by a negative number reverses the direction of the inequality). Thus  $x$  could be less than 6 (for example,  $x$  could equal 2), but does not have to be less than 6 (for example,  $x$  could equal 7).
- (2) INSUFFICIENT: Since the question stem tells us that  $y$  is an integer, the statement  $|y| \leq 1$  implies that  $y$  equals -1, 0, or 1. Substituting these values for  $y$  into the expression  $|x| \cdot y > -9$ , we see that  $x$  could be less than 6, greater than 6, or even equal to 6. This is particularly obvious if  $y = 0$ ; in that case,  $x$  could be any integer at all. (You can test this by picking actual numbers.)
- (1) AND (2) INSUFFICIENT: If  $y$  is negative and  $|y| \leq 1$ , then  $y$  must equal -1. We have already determined from our analysis of statement (1) that a value of  $y = -1$  is consistent both with  $x$  being less than 6 and with  $x$  *not* being less than 6.
- The correct answer is E.

40. We can rephrase the question by opening up the absolute value sign. There are two scenarios for the inequality  $|n| < 4$ .

If  $n > 0$ , the question becomes "Is  $n < 4$ ?"

If  $n < 0$ , the question becomes: "Is  $n > -4$ ?"

We can also combine the questions: "Is  $-4 < n < 4$ ?" ( $n$  is not equal to 0)

(1) SUFFICIENT: The solution to this inequality is  $n > 4$  (if  $n > 0$ ) or  $n < -4$  (if  $n < 0$ ). This provides us with enough information to guarantee that  $n$  is definitely NOT between -4 and 4. Remember that an absolute no is sufficient!

(2) INSUFFICIENT: We can multiply both sides of the inequality by  $|n|$  since it is definitely positive. To solve the inequality  $|n| \times n < 1$ , let's plug values. If we start with negative values, we see that  $n$  can be any negative value since  $|n| \times n$  will always be negative and therefore less than 1. This is already enough to show that the statement is insufficient because  $n$  might not be between -4 and 4.

The correct answer is A.

41. Note that one need not determine the values of both  $x$  and  $y$  to solve this problem; the value of product  $xy$  will suffice.

(1) SUFFICIENT: Statement (1) can be rephrased as follows:

$$\begin{aligned} -4x - 12y &= 0 \\ -4x &= 12y \\ x &= -3y \end{aligned}$$

If  $x$  and  $y$  are non-zero integers, we can deduce that they must have opposite signs: one positive, and the other negative. Therefore, this last equation could be rephrased as

$$|x| = 3|y|$$

We don't know whether  $x$  or  $y$  is negative, but we do know that they have the opposite signs. Converting both variables to absolute value cancels the negative sign in the expression  $x = -3y$ .

We are left with two equations and two unknowns, where the unknowns are  $|x|$  and  $|y|$ :

$$\begin{aligned} |x| + |y| &= 32 \\ |x| - 3|y| &= 0 \end{aligned}$$

Subtracting the second equation from the first yields

$$\begin{aligned} 4|y| &= 32 \\ |y| &= 8 \end{aligned}$$

Substituting 8 for  $|y|$  in the original equation, we can easily determine that  $|x| = 24$ . Because we know that one of either  $x$  or  $y$  is negative and the other positive,  $xy$  must be the negative product of  $|x|$  and  $|y|$ , or  $-8(24) = -192$ .

(2) INSUFFICIENT: Statement (2) also provides two equations with two unknowns:

$$\begin{aligned} |x| + |y| &= 32 \\ |x| - |y| &= 16 \end{aligned}$$

Solving these equations allows us to determine the values of  $|x|$  and  $|y|$ :  $|x| = 24$  and  $|y| = 8$ . However, this gives no information about the sign of  $x$  or  $y$ . The product  $xy$  could either be  $-192$  or  $192$ .

The correct answer is A.

42. (1) INSUFFICIENT: Since this equation contains two variables, we cannot determine the value of  $y$ . We can, however, note that the absolute value expression  $|x^2 - 4|$  must be greater than or equal to 0. Therefore,  $3|x^2 - 4|$  must be greater than or equal to 0, which in turn means that  $y - 2$  must be greater than or equal to 0. If  $y - 2 \geq 0$ , then  $y \geq 2$ .

(2) INSUFFICIENT: To solve this equation for  $y$ , we must consider both the positive and negative values of the absolute value expression:

$$\begin{aligned} \text{If } 3 - y > 0, \text{ then } 3 - y &= 11 \\ y &= -8 \end{aligned}$$

$$\text{If } 3 - y < 0, \text{ then } 3 - y = -11$$

$$y = 14$$

Since there are two possible values for  $y$ , this statement is insufficient.

(1) AND (2) SUFFICIENT: Statement (1) tells us that  $y$  is greater than or equal to 2, and statement (2) tells us that  $y = -8$  or 14. Of the two possible values, only 14 is greater than or equal to 2. Therefore, the two statements together tell us that  $y$  must equal 14.

The correct answer is C.

43. The question asks whether  $x$  is positive. The question is already as basic as it can be made to be, so there is no need to rephrase it; we can go straight to the statements.

(1) SUFFICIENT: Here, we are told that  $|x + 3| = 4x - 3$ . When dealing with equations containing variables and absolute values, we generally need to consider the possibility that there may be more than one value for the unknown that could make the equation work. In order to solve this particular equation, we need to consider what happens when  $x + 3$  is positive and when it is negative (remember, the absolute value is the same in either case). First, consider what happens if  $x + 3$  is positive. If  $x + 3$  is positive, it is as if there were no absolute value bars, since the absolute value of a positive is still positive:

$$\begin{aligned}x + 3 &= 4x - 3 \\6 &= 3x \\2 &= x\end{aligned}$$

So when  $x + 3$  is positive,  $x = 2$ , a positive value. If we plug 2 into the original equation, we see that it is a valid solution:

$$\begin{aligned}|2 + 3| &= 4(2) - 3 \\|5| &= 8 - 3 \\5 &= 5\end{aligned}$$

Now let's consider what happens when  $x + 3$  is negative. To do so, we multiply  $x + 3$  by -1:

$$\begin{aligned}-1(x + 3) &= 4x - 3 \\-x - 3 &= 4x - 3 \\0 &= 5x \\0 &= x\end{aligned}$$

But if we plug 0 into the original equation, it is *not* a valid solution:

$$\begin{aligned}|0 + 3| &= 4(0) - 3 \\|3| &= 0 - 3 \\3 &= -3\end{aligned}$$

Therefore, there is no solution when  $x + 3$  is negative and we know that 2 is the only solution possible and we can say that  $x$  is definitely positive.

Alternatively, we could have noticed that the right-hand side of the original equation must be positive (because it equals the absolute value of  $x + 3$ ). If  $4x - 3$  is positive,  $x$  must be positive. If  $x$  were negative,  $4x$  would be negative and a negative minus a positive is negative.

(2) INSUFFICIENT: Here, again, we must consider the various combinations of positive and negative for both sides. Let's first assume that both sides are positive (which is

equivalent to assuming both sides are negative):

$$|x - 3| = |2x - 3|$$

$$x - 3 = 2x - 3$$

$$0 = x$$

So when both sides are positive,  $x = 0$ . We can verify that this solution is valid by plugging 0 into the original equation:

$$|0 - 3| = |2(0) - 3|$$

$$|-3| = |-3|$$

$$3 = 3$$

Now let's consider what happens when only one side is negative; in this case, we choose the right-hand side:

$$|x - 3| = |2x - 3|$$

$$x - 3 = -(2x - 3)$$

$$x - 3 = -2x + 3$$

$$3x = 6$$

$$x = 2$$

We can verify that this is a valid solution by plugging 2 into the original equation:

$$|2 - 3| = |2(2) - 3|$$

$$|-1| = |1|$$

$$1 = 1$$

Therefore, both 2 and 0 are valid solutions and we cannot determine whether  $x$  is positive, since one value of  $x$  is zero, which is not positive, and one is positive.

The correct answer is A.

44. Note that the question is asking for the absolute value of  $x$  rather than just the value of  $x$ . Keep this in mind when you analyze each statement.

(1) SUFFICIENT: Since the value of  $x^2$  must be non-negative, the value of  $(x^2 + 16)$  is always positive, therefore  $|x^2 + 16|$  can be written  $x^2 + 16$ . Using this information, we can solve for  $x$ :

$$|x^2 + 16| - 5 = 27$$

$$x^2 + 16 - 5 = 27$$

$$x^2 + 11 = 27$$

$$x^2 = 16$$

$$x = 4 \text{ or } x = -4$$

Since  $|-4| = |4| = 4$ , we know that  $|x| = 4$ ; this statement is sufficient.

(2) SUFFICIENT:

$$x^2 = 8x - 16$$

$$x^2 - 8x + 16 = 0$$

$$(x - 4)^2 = 0$$

$$(x - 4)(x - 4) = 0$$

$$x = 4$$

Therefore,  $|x| = 4$ ; this statement is sufficient.

The correct answer is D.

45. First, let us take the expression,  $x^2 - 2xy + y^2 - 9 = 0$ . After adding 9 to both sides of the equation, we get  $x^2 - 2xy + y^2 = 9$ . Since we are interested in the variables  $x$  and  $y$ , we need to rearrange the expression  $x^2 - 2xy + y^2$  into an expression that contains terms for  $x$  and  $y$  individually. This suggests that factoring the expression into a product of two sums is in order here. Since the coefficients of both the  $x^2$  and the  $y^2$  terms are 1 and the coefficient of the  $xy$  term is negative, the most logical first guess for factors is  $(x - y)(x - y)$  or  $(x - y)^2$ . (We can quickly confirm that these are the correct factors by multiplying out  $(x - y)(x - y)$  and verifying that this is equal to  $x^2 - 2xy + y^2$ .) Hence, we now have  $(x - y)^2 = 9$  which means that  $x - y = 3$  or  $x - y = -3$ . Since the question states that  $x > y$ ,  $x - y$  must be greater than 0 and the only consistent answer is  $x - y = 3$ .

We now have two simple equations and two unknowns:

$$\begin{aligned}x - y &= 3 \\x + y &= 15\end{aligned}$$

After adding the bottom equation to the top equation we are left with  $2x = 18$ ; hence  $x = 9$ .

If we are observant, we can apply an alternative method that uses a "trick" to solve this very quickly. Note, of all the answers,  $x = 9$  is the only answer that is consistent with both  $x > y$  and  $x + y = 15$ . Hence  $x = 9$  must be the answer.

The correct answer is E.

#### 46.

The expression is equal to  $n$  if  $n \geq 0$ , but  $-n$  if  $n \leq 0$ . This means that EITHER

$$n < 1 \text{ if } n \geq 0$$

OR

$$-n < 1 \text{ (that is, } n > -1) \text{ if } n \leq 0.$$

If we combine these two possibilities, we see that the question is really asking whether  $-1 < n < 1$ .

(1) INSUFFICIENT: If we add  $n$  to both sides of the inequality, we can rewrite it as the following:

$$n^x < n.$$

Since this is a Yes/No question, one way to handle it is to come up with sample values *that satisfy this condition* and then see whether these values give us a "yes" or a "no" to the question.

$$n = \frac{1}{2} \text{ and } x = 2 \text{ are legal values since } (1/2)^2 < 1/2$$

These values yield a YES to the question, since  $n$  is between -1 and 1.

$$n = -3 \text{ and } x = 3 \text{ are also legal values since } 3^{-3} = 1/27 < 3$$

These values yield a NO to the question since  $n$  is greater than 1.

With legal values yielding a "yes" and a "no" to the original question, statement (1) is insufficient.

(2) INSUFFICIENT:  $x^{-1} = -2$  can be rewritten as  $x = -2^{-1} = -1/2$ . However, this statement contains no information about  $n$ .

(1) AND (2) SUFFICIENT: If we combine the two statements by plugging the value for  $x$  into the first statement, we get  $n^{-1/2} < n$ .

The only values for  $n$  that satisfy this inequality are greater than 1.

Negative values for  $n$  are not possible. Raising a number to the exponent of  $-1/2$  is equivalent to taking the reciprocal of the square root of the number. However, it is not possible (within the real number system) to take the square root of a negative number.

A fraction less than 1, such as  $1/2$ , becomes a LARGER number when you square root it ( $(1/2)^{1/2} = \sim 0.7$ ). However, the new number is still less than 1. When you reciprocate that value, you get a number ( $(1/2)^{-1/2} = \sim 1.4$ ) that is LARGER than 1 and therefore LARGER than the original value of  $n$ .

Finally, all values of  $n$  greater than 1 satisfy the inequality  $n^{-1/2} < n$ .

For instance, if  $n = 4$ , then  $n^{-1/2} = 1/2$ . Taking the square root of a number larger than 1 makes the number smaller, though still greater than 1 -- and then taking the reciprocal of that number makes the number smaller still.

Since the two statements together tell us that  $n$  must be greater than 1, we know the definitive answer to the question "Is  $n$  between -1 and 1?" Note that the answer to this question is "No," which is as good an answer as "Yes" to a Yes/No question on Data Sufficiency.

The correct answer is (C).

#### 47.

In problems involving variables in the exponent, it is helpful to rewrite an equation or inequality in exponential terms, and it is especially helpful, if possible, to rewrite them with exponential terms that have the same base.

$$0.04 = 1/25 = 5^{-2}$$

We can rewrite the question in the following way: "Is  $5^n < 5^{-2}$ ?"

The only way  $5^n$  could be less than  $5^{-2}$  would be if  $n$  is less than -2. We can rephrase the question: "Is  $n < -2$ ?"

(1) SUFFICIENT: Let's simplify (or rephrase) the inequality given in this statement.

$$(1/5)^n > 25$$

$$(1/5)^n > 5^2$$

$$5^{-n} > 5^2$$

$$-n > 2$$

$$n < -2 \quad (\text{recall that the inequality sign flips when dividing by a negative number})$$

This is sufficient to answer our rephrased question.

(2) INSUFFICIENT:  $n^3$  will be smaller than  $n^2$  if  $n$  is either a negative number or a fraction between 0 and 1. We cannot tell if  $n$  is smaller than -2.

The correct answer is A.

**48.**

Before we proceed with the analysis of the statements, let's rephrase the question. Note that we can simplify the question by rearranging the terms in the ratio:  $2x/3y = (2/3)(x/y)$ . Therefore, to answer the question, we simply need to find the ratio  $x/y$ . Thus, we can rephrase the question: "What is  $x/y$ ?"

(1) INSUFFICIENT: If  $x^2/y^2 = 36/25$ , you may be tempted to take the positive square root of both sides and conclude that  $x/y = 6/5$ . However, since even exponents hide the sign of the variable, both  $6/5$  and  $-6/5$ , when squared, will yield the value of  $36/25$ . Thus, the value of  $x/y$  could be either  $6/5$  or  $-6/5$ .

(2) INSUFFICIENT: This statement provides only a range of values for  $x/y$  and is therefore insufficient.

(1) AND (2) SUFFICIENT: From the first statement, we know that  $x/y = 6/5 = 1.2$  or  $x/y = -6/5 = -1.2$ . From the second statement, we know that  $x^5/y^5 = (x/y)^5 > 1$ . Note that if  $x/y = 1.2$ , then  $(x/y)^5 = 1.2^5$ , which is always greater than 1, since the base of the exponent (i.e. 1.2) is greater than 1. However, if  $x/y = -1.2$ , then  $(x/y)^5 = (-1.2)^5$ , which is always negative and does not satisfy the second statement. Thus, since we know from the second statement that  $(x/y) > 1$ , the value of  $x/y$  must be 1.2.

The correct answer is C.

**49.**

$x - y + 1 - (x + y - 1) = 2 - 2y$ , we just need to know the situation of  $y$ .  
From statement 2, we know that  $y < 0$ , so,  $2 - 2y > 0$   
Answer is B

**50.**

(1) INSUFFICIENT: If we multiply this equation out, we get:

$$x^2 + 2xy + y^2 = 9a$$

If we try to solve this expression for  $x^2 + y^2$ , we get

$$x^2 + y^2 = 9a - 2xy$$

Since the value of this expression depends on the value of  $x$  and  $y$ , we don't have enough information.

(2) INSUFFICIENT: If we multiply this equation out, we get:

$$x^2 - 2xy + y^2 = a$$

If we try to solve this expression for  $x^2 + y^2$ , we get

$$x^2 + y^2 = a + 2xy$$

Since the value of this expression depends on the value of  $x$  and  $y$ , we don't have enough information.

(1) AND (2) SUFFICIENT: We can combine the two expanded forms of the equations from the

two statements by adding them:

$$\begin{aligned}x^2 + 2xy + y^2 &= 9a \\x^2 - 2xy + y^2 &= a\end{aligned}$$

$$\begin{aligned}2x^2 + 2y^2 &= 10a \\x^2 + y^2 &= 5a\end{aligned}$$

If we substitute this back into the original question, the question becomes: "Is  $5a > 4a$ ?"

Since  $a > 0$ ,  $5a$  will always be greater than  $4a$ .

The correct answer is C.

## 51.

(1) INSUFFICIENT: Statement (1) is insufficient because  $y$  is unbounded when both  $x$  and  $k$  can vary. Therefore  $y$  has no definite maximum.

To show that  $y$  is unbounded, let's calculate  $y$  for a special sequence of  $(x, k)$  pairs. The sequence starts at  $(-2, 1)$  and doubles both values to get the next  $(x, k)$  pair in the sequence.

$$\begin{aligned}y_1 &= |-2 - 1| - |-2 + 1| = 3 - 1 = 2 \\y_2 &= |-4 - 2| - |-4 + 2| = 6 - 2 = 4 \\y_3 &= |-8 - 4| - |-8 + 4| = -12 + 4 = 8 \\&\text{etc.}\end{aligned}$$

In this sequence  $y$  doubles each time so it has no definite maximum, so statement (1) is insufficient.

(2) SUFFICIENT: Statement (2) says that  $k = 3$ , so  $y = |x - 3| - |x + 3|$ . Therefore to maximize  $y$  we must maximize  $|x - 3|$  while simultaneously trying to minimize  $|x + 3|$ . This state holds for very large negative  $x$ . Let's try two different large negative values for  $x$  and see what happens:

$$\begin{aligned}\text{If } x &= -100 \text{ then:} \\y &= |-100 - 3| - |-100 + 3| \\y &= 103 - 97 = 6\end{aligned}$$

$$\begin{aligned}\text{If } x &= -101 \text{ then:} \\y &= |-101 - 3| - |-101 + 3| \\y &= 104 - 98 = 6\end{aligned}$$

We see that the two expressions increase at the same rate, so their difference remains the same. As  $x$  decreases from 0,  $y$  increases until it reaches 6 when  $x = -3$ . As  $x$  decreases further,  $y$  remains at 6 which is its maximum value.

The correct answer is B.

## 52.

When we plug a few values for  $x$ , we see that the expression doesn't seem to go below the value of 2. It is important to try both fractions (less than 1) and integers greater than 1. Let's try to

mathematically prove that this expression is always greater than or equal to 2. Is  $x + \frac{1}{x} \geq 2$  ?

Since  $x > 0$ , we can multiply both sides of the inequality by  $x$ :

$$x^2 + 1 \geq 2x$$

$$x^2 - 2x + 1 \geq 0$$

$$(x - 1)^2 \geq 0$$

The left side of this inequality is always positive, so in fact the original inequality holds.

The correct answer is D.

**53.**

We can rephrase the question by manipulating it algebraically:

$$(|x^1 * y^1|)^{-1} > xy$$

$$(|1/x * 1/y|)^{-1} > xy$$

$$(|1/xy|)^{-1} > xy$$

$$1/(|1/(xy)|) > xy$$

Is  $|xy| > xy$ ?

The question can be rephrased as "Is the absolute value of  $xy$  greater than  $xy$ ?" And since  $|xy|$  is never negative, this is only true when  $xy < 0$ . If  $xy > 0$  or  $xy = 0$ ,  $|xy| = xy$ . Therefore, this question is really asking whether  $xy < 0$ , i.e. whether  $x$  and  $y$  have opposite signs.

(1) SUFFICIENT: If  $xy > 1$ ,  $xy$  is definitely positive. For  $xy$  to be positive,  $x$  and  $y$  must have the same sign, i.e. they are both positive or both negative. Therefore  $x$  and  $y$  definitely *do not* have opposite signs and  $|xy|$  is equal to  $xy$ , not greater. This is an absolute "no" to the question and therefore sufficient.

(2) INSUFFICIENT:  $x^2 > y^2$

Algebraically, this inequality reduces to  $|x| > |y|$ . This tells us nothing about the sign of  $x$  and  $y$ . They could have the same signs or opposite signs.

The correct answer is A: Statement (1) alone is sufficient, but statement (2) alone is not.

**54.**

First, rephrase the question stem by subtracting  $xy$  from both sides: Is  $xy < 0$ ? The question is simply asking if  $xy$  is negative.

Statement (1) tells us that  $\frac{x^2}{y} < 0$ .

Since  $x^2$  must be positive, we know that  $y$  must be negative. However this does not provide sufficient information to determine whether or not  $xy$  is negative.

Statement (2) can be simplified as follows:

$$x^9(y^3)^3 < (x^2)^4(y^8)$$

$$x^9y^9 < x^8y^8$$

$$(xy)^9 < (xy)^8$$

Statement (2) is true for all negative numbers. However, it is also true for positive fractions. Therefore, statement (2) does not provide sufficient information to determine whether or not  $xy$  is positive or negative.

There is also no way to use the fact that  $y$  is negative (from statement 1) to eliminate either of the two cases for which statement (2) is true. Statement (2) does not provide any information about  $x$ , which is what we would need in order to use both statements in conjunction.

Therefore the answer is (E): Statements (1) and (2) TOGETHER are NOT sufficient.

### 55.

1.  $w > -2$ , insufficient.
  2.  $w > 1$  or  $w < -1$ , insufficient.
  - 1+2,  $w > 1$  or  $-2 < w < -1$ , still insufficient.
- Answer is E

### 56.

Since Missile 1's rate increases by a factor of  $\sqrt{x}$  every 10 minutes, Missile 1 will be traveling at a speed of  $x^4$  miles per hour after 60 minutes:

minutes	0-10	10-20	20-30	30-40	40-50	50-60	60+
speed	$x$	$x\sqrt{x}$	$x^2$	$x^2\sqrt{x}$	$x^3$	$x^3\sqrt{x}$	$x^4$

And since Missile 2's rate doubles every 10 minutes, Missile 2 will be traveling at a speed of  $2^6y$  after 60 minutes:

minutes	0-10	10-20	20-30	30-40	40-50	50-60	60+
speed	$y$	$2y$	$2^2y$	$2^3y$	$2^4y$	$2^5y$	$2^6y$

The question then becomes: Is  $x^4 > 2^6y$ ?

Statement (1) tells us that  $x = \sqrt{y}$ . Squaring both sides yields  $x^2 = y$ . We can substitute for  $y$ : Is  $x^4 > 2^6x^2$ ? If we divide both sides by  $x^2$ , we get: Is  $x^2 > 2^6$ ? We can further simplify by taking the square root of both sides: Is  $x > 2^3$ ? We still cannot answer this, so statement (1) alone is NOT sufficient to answer the question.

Statement (2) tells us that  $x > 8$ , which tells us nothing about the relationship between  $x$  and  $y$ . Statement (2) alone is NOT sufficient to answer the question.

Taking the statements together, we know from statement (1) that the question can be rephrased: Is  $x > 2^3$ ? From statement (2) we know certainly that  $x > 8$ , which is another way

of expressing  $x > 2^3$ . So using the information from both statements, we can answer definitively that after 1 hour, Missile 1 is traveling faster than Missile 2.

The correct answer is C: Statements (1) and (2) taken together are sufficient to answer the question, but neither statement alone is sufficient.

**57.**

Simplifying the original expression yields:

$$\frac{8xy^3 + 8x^3y}{1} = \frac{2x^2y^2}{2^{-3}}$$

$$2^{-3}(8xy^3 + 8x^3y) = 1(2x^2y^2)$$

$$\frac{1}{8}(8xy^3 + 8x^3y) = 2x^2y^2$$

$$\frac{8xy^3 + 8x^3y}{8} = 2x^2y^2$$

$$\frac{8(xy^3 + x^3y)}{8} = 2x^2y^2$$

$$xy^3 + x^3y = 2x^2y^2$$

$$xy^3 + x^3y - 2x^2y^2 = 0$$

$$xy(y^2 + x^2 - 2xy) = 0$$

$$xy(y - x)^2 = 0$$

Therefore:  $xy = 0$  or  $y - x = 0$ . Our two solutions are:  $xy = 0$  or  $y = x$ .

Statement (1) says  $y > x$  so  $y$  cannot be equal to  $x$ . Therefore,  $xy = 0$ . Statement (1) is sufficient.

Statement (2) says  $x < 0$ . We cannot say whether  $x = y$  or  $xy = 0$ . Statement (2) is not sufficient.

The correct answer is A.

**58.**

If  $(a - b)c < 0$ , the expression  $(a - b)$  and the variable  $c$  must have opposite signs.

Let's check each answer choice:

(A) UNCERTAIN: If  $a < b$ ,  $a - b$  would be negative. It is possible for  $a - b$  to be negative according to the question.

(B) UNCERTAIN: It is possible for  $c$  to be negative according to the question.

(C) UNCERTAIN: This means that  $-1 < c < 1$ , which is possible according to the question.

(D) FALSE: If we rewrite this expression, we get  $ac - bc > 0$ . Then, if we factor this, we get:  $(a - b)c > 0$ . This directly contradicts the information given in the question, which states that  $(a - b)c < 0$ .

(E) UNCERTAIN: If we factor this expression, we get  $(a + b)(a - b) < 0$ . This tells us that the expressions  $a + b$  and  $a - b$  have opposite signs, which is possible according to the question. The correct answer is D.

**59.**

If  $|ab| > ab$ ,  $ab$  must be negative. If  $ab$  were positive the absolute value of  $ab$  would equal  $ab$ . We can rephrase this question: "Is  $ab < 0$ ?"

I. UNCERTAIN: We know nothing about the sign of  $b$ .

II. UNCERTAIN: We know nothing about the sign of  $a$ .

III. TRUE: This answers the question directly.

The correct answer is C.

**60.**

Since  $c > 0$  and  $d > c$ ,  $c$  and  $d$  must be positive.  $b$  could be negative or positive. Let's look at each answer choice:

(A) UNCERTAIN:  $bcd$  could be greater than zero if  $b$  is positive.

(B) UNCERTAIN:  $b + cd$  could be less than zero if  $b$  is negative and its absolute value is greater than that of  $cd$ . For example:  $b = -12$ ,  $c = 2$ ,  $d = 5$  yields  $-12 + (2)(5) = -2$ .

(C) FALSE: Contrary to this expression,  $b - cd$  must be negative. We could think of this expression as  $b + (-cd)$ .  $cd$  itself will always be positive, so we are adding a negative number to  $b$ . If  $b < 0$ , the result is negative. If  $b > 0$ , the result is still negative because a positive  $b$  must still be less than  $cd$  (remember that  $b < c < d$  and  $b$ ,  $c$  and  $d$  are integers).

(D) UNCERTAIN: This is possible if  $b$  is negative.

(E) UNCERTAIN: This is possible if  $b$  is negative.

The correct answer is C.

**61.**

Let's look at the answer choices one by one:

(A) POSSIBLE:  $c$  can be greater than  $b$  if  $a$  is much bigger than  $d$ . For example, if  $c = 2$ ,  $b = 1$ ,  $a = 10$  and  $d = 3$ ,  $ab(10)$  is still greater than  $cd(6)$ , despite the fact that  $c > b$ .

(B) POSSIBLE: The same reasoning from (A) applies.

**(C) IMPOSSIBLE:** Since  $a$ ,  $b$ ,  $c$  and  $d$  are all positive we can cross multiply this fraction to yield  $ab < cd$ , the opposite of the inequality in the question.

(D) DEFINITE: Since  $a$ ,  $b$ ,  $c$  and  $d$  are all positive, we can cross multiply this fraction to yield  $ab > cd$ , which is the same inequality as that in the question.

(E) DEFINITE: Since  $a$ ,  $b$ ,  $c$  and  $d$  are all positive, we can simply unsquare both sides of the inequality. We will then have  $cd < ab$ , which is the same inequality as that in the question.

The correct answer is C.

**62.**

We can rephrase the question by subtracting  $y$  from both sides of the inequality: Is  $x > -y$ ?

(1) INSUFFICIENT: If we add  $y$  to both sides, we see that  $x$  is greater than  $y$ . We can use numbers here to show that this does not necessarily mean that  $x > -y$ . If  $x = 4$  and  $y = 3$ , then it is true that  $x$  is also greater than  $-y$ . However if  $x = 4$  and  $y = -5$ ,  $x$  is greater than  $y$  but it is NOT greater than  $-y$ .

(2) INSUFFICIENT: If we factor this inequality, we come up  $(x + y)(x - y) > 0$ . For the product of  $(x + y)$  and  $(x - y)$  to be greater than zero, they must have the same sign, i.e. both negative or both positive. This does not help settle the issue of the sign of  $x + y$ .

(1) AND (2) SUFFICIENT: From statement 2 we know that  $(x + y)$  and  $(x - y)$  must have the same sign, and from statement 1 we know that  $(x - y)$  is positive, so it follows that  $(x + y)$  must be positive as well.

The correct answer is C.

### 63.

We can rephrase the question by opening up the absolute value sign. In other words, we must solve all possible scenarios for the inequality, remembering that the absolute value is always a positive value. The two scenarios for the inequality are as follows:

If  $x > 0$ , the question becomes "Is  $x < 1$ ?"

If  $x < 0$ , the question becomes: "Is  $x > -1$ ?"

We can also combine the questions: "Is  $-1 < x < 1$ ?"

Since Statement 2 is less complex than Statement 1, begin with Statement 2 and a BD/ACE grid.

(1) INSUFFICIENT: There are three possible equations here if we open up the absolute value signs:

1. If  $x < -1$ , the values inside the absolute value symbols on both sides of the equation are negative, so we must multiply each through by  $-1$  (to find its opposite, or positive, value):

$$|x + 1| = 2|x - 1| \longrightarrow -(x + 1) = 2(1 - x) \longrightarrow x = 3$$

(However, this is invalid since in this scenario,  $x < -1$ .)

2. If  $-1 < x < 1$ , the value inside the absolute value symbols on the left side of the equation is positive, but the value on the right side of the equation is negative. Thus, only the value on the right side of the equation must be multiplied by  $-1$ :

$$|x + 1| = 2|x - 1| \longrightarrow x + 1 = 2(1 - x) \longrightarrow x = 1/3$$

3. If  $x > 1$ , the values inside the absolute value symbols on both sides of the equation are positive. Thus, we can simply remove the absolute value symbols:

$$|x + 1| = 2|x - 1| \longrightarrow x + 1 = 2(x - 1) \longrightarrow x = 3$$

Thus  $x = 1/3$  or  $3$ . While  $1/3$  is between  $-1$  and  $1$ ,  $3$  is not. Thus, we cannot answer the question.

(2) INSUFFICIENT: There are two possible equations here if we open up the absolute value sign:

1. If  $x > 3$ , the value inside the absolute value symbols is greater than zero. Thus, we can simply remove the absolute value symbols:

$$|x - 3| > 0 \longrightarrow x - 3 > 0 \longrightarrow x > 3$$

2. If  $x < 3$ , the value inside the absolute value symbols is negative, so we must multiply through by  $-1$  (to find its opposite, or positive, value).

$$|x-3| > 0 \longrightarrow 3-x > 0 \longrightarrow x < 3$$

If  $x$  is either greater than 3 or less than 3, then  $x$  is anything but 3. This does not answer the question as to whether  $x$  is between -1 and 1.

(1) AND (2) SUFFICIENT: According to statement (1),  $x$  can be 3 or  $1/3$ . According to statement (2),  $x$  cannot be 3. Thus using both statements, we know that  $x = 1/3$  which IS between -1 and 1.

**64.**

We can rephrase this question as: "Is  $a$  farther away from zero than  $b$ , on the number-line?" We can solve this question by picking numbers:

Since Statement 2 is less complex than Statement 1, begin with Statement 2 and a BD/ACE grid.

(1) INSUFFICIENT: Picking values that meet the criteria  $b < -a$  demonstrates that this is not enough information to answer the question.

$a$	$b$	Is $ a  >  b $ ?
2	-5	NO
-5	2	YES

(2) INSUFFICIENT: We have no information about  $b$ .

(1) AND (2) INSUFFICIENT: Picking values that meet the criteria  $b < -a$  and  $a < 0$  demonstrates that this is not enough information to answer the question.

$a$	$b$	Is $ a  >  b $ ?
-2	-5	NO
-5	2	YES

The correct answer is E.

**65.**

Since  $|r|$  is always positive, we can multiply both sides of the inequality by  $|r|$  and rephrase the question as: Is  $r^2 < |r|$ ? The only way for this to be the case is if  $r$  is a nonzero fraction between -1 and 1.

(1) INSUFFICIENT: This does not tell us whether  $r$  is between -1 and 1. If  $r = -1/2$ ,  $|r| = 1/2$  and  $r^2 = 1/4$ , and the answer to the rephrased question is YES. However, if  $r = 4$ ,  $|r| = 4$  and  $r^2 = 16$ , and the answer to the question is NO.

(2) INSUFFICIENT: This does not tell us whether  $r$  is between -1 and 1. If  $r = 1/2$ ,  $|r| = 1/2$  and  $r^2 = 1/4$ , and the answer to the rephrased question is YES. However, if  $r = -4$ ,  $|r| = 4$  and  $r^2 = 16$ , and the answer to the question is NO.

(1) AND (2) SUFFICIENT: Together, the statements tell us that  $r$  is between -1 and 1. The square of a proper fraction (positive or negative) will always be smaller than the absolute value of that proper fraction.

The correct answer is C.

**66.**

One way to solve equations with absolute values is to solve for  $x$  over a series of intervals. In each interval of  $x$ , the sign of the expressions within each pair of absolute value indicators does not change.

In the equation  $|x-2| - |x-3| = |x-5|$ , there are 4 intervals of interest:

$x < 2$ : In this interval, the value inside each of the three absolute value expressions is negative.

$2 < x < 3$ : In this interval, the value inside the first absolute value expression is positive, while the value inside the other two absolute value expressions is negative.

$3 < x < 5$ : In this interval, the value inside the first two absolute value expressions is positive, while the value inside the last absolute value expression is negative.

$5 < x$ : In this interval, the value inside each of the three absolute value expressions is positive. Use each interval for  $x$  to rewrite the equation so that it can be evaluated without absolute value signs.

For the first interval,  $x < 2$ , we can solve the equation by rewriting each of the expressions inside the absolute value signs as negative (and thereby remove the absolute value signs):

$$\begin{aligned} -x + 2 - (-x + 3) &= -x + 5 \\ -x + 2 + x - 3 &= -x + 5 \\ x &= 6 \end{aligned}$$

Notice that the solution  $x = 6$  is NOT a valid solution since it lies outside the interval  $x < 2$ .

(Remember, we are solving the equation for  $x$  SUCH THAT  $x$  is within the interval of interest).

For the second interval  $2 < x < 3$ , we can solve the equation by rewriting the expression inside the first absolute value sign as positive and by rewriting the expressions inside the other absolute values signs as negative:

$$\begin{aligned} x - 2 - (-x + 3) &= -x + 5 \\ x - 2 + x - 3 &= -x + 5 \\ 3x &= 10 \\ x &= \frac{10}{3} \end{aligned}$$

Notice, again, that the solution  $x = \frac{10}{3}$  is NOT a valid solution since it lies outside the interval  $2 < x < 3$ .

For the third interval  $3 < x < 5$ , we can solve the equation by rewriting the expressions inside the first two absolute value signs as positive and by rewriting the expression inside the last absolute value sign as negative:

$$\begin{aligned} x - 2 - (x - 3) &= -x + 5 \\ x - 2 - x + 3 &= -x + 5 \\ x &= 4 \end{aligned}$$

The solution  $x = 4$  is a valid solution since it lies within the interval  $3 < x < 5$ .

Finally, for the fourth interval  $5 < x$ , we can solve the equation by rewriting each of the expressions inside the absolute value signs as positive:

$$\begin{aligned} x - 2 - (x - 3) &= x - 5 \\ x - 2 - x + 3 &= x - 5 \\ x &= 6 \end{aligned}$$

The solution  $x = 6$  is a valid solution since it lies within the interval  $5 < x$ .

We conclude that the only two solutions of the original equation are  $x = 4$  and  $x = 6$ . Only answer choice C contains all of the solutions, both 4 and 6, as part of its set. Therefore, C is the correct answer.

### 67.

Statement (1) tells us that  $a$  is either 1 or  $-1$ , that  $b$  is either 2 or  $-2$ , and that  $c$  is either 3 or  $-3$ . Therefore, we cannot find ONE unique value for the expression in the question.

For example, let  $b = 2$ , and  $c = 3$ . If  $a = 1$ , the expression in the question stem evaluates to  $(1 + 8 + 27) / (1 \times 2 \times 3) = 36/6 = 6$ . However, if  $a = -1$ , the expression evaluates to  $(-1 + 8 + 27) / (-1 \times 2 \times 3) = 34/(-6) = -17/3$ . Thus, statement (1) is not sufficient to answer the question.

Statement (2) tells us that  $a + b + c = 0$ . Therefore,  $c = -(a + b)$ . By substituting this value of  $c$  into the expression in the question, we can simplify the numerator of the expression as follows:

$$\begin{aligned} a^3 + b^3 + c^3 &= a^3 + b^3 + (-(a + b))^3 = a^3 + b^3 - (a + b)^3 \\ &= a^3 + b^3 - (a^2 + 2ab + b^2)(a + b) \\ &= a^3 + b^3 - (a^3 + 2a^2b + ab^2 + a^2b + 2ab^2 + b^3) \\ &= a^3 + b^3 - (a^3 + b^3 + 3a^2b + 3ab^2) \\ &= -(3a^2b + 3ab^2) = -(a + b)(3ab) = c(3ab) \\ &= 3abc \end{aligned}$$

From this, we can rewrite the expression in the question as  $\frac{a^3 + b^3 + c^3}{abc} = \frac{3abc}{abc} = 3$ .

Thus, statement (2) alone is sufficient to solve the expression. The correct answer is B.

### 68.

First, rewrite the equation for  $x$  by breaking down each of the 8's into its prime components ( $2^3$ ).

$$\text{Thus, } x = 2^b - [(2^3)^{30} + (2^3)^5] = 2^b - [2^{90} + 2^{15}].$$

The question asks us to minimize the value of  $w$ . Given that  $w$  is simply the absolute value of  $x$ , the question is asking us to find a value for  $b$  that makes the expression  $2^b - [2^{90} + 2^{15}]$  as close to 0 as possible. In other words, for what value of  $b$ , will  $2^b$  approximately equal  $2^{90} + 2^{15}$ .

The important thing to keep in mind is that the expression  $2^{90}$  is so much greater than the expression  $2^{15}$  that the expression  $2^{15}$  is basically a negligible part of the equation.

Therefore, in order for  $2^b$  to approximate  $2^{90} + 2^{15}$ , the best value for  $b$  among the answer choices is 90. It is tempting to select an answer such as 91 to somehow "account" for the  $2^{15}$ . However, consider that  $2^{91} = 2 \times 2^{90}$ . In other words,  $2^{91}$  is *twice* as large as  $2^{90}$ !

In contrast,  $2^{90}$  is much closer in value to the expression  $2^{90} + 2^{15}$ , since  $2^{15}$  does not even come close to doubling the size of  $2^{90}$ .

The correct answer is B.

### 69.

Theoretically, any absolute value expression represents two scenarios. For example  $|x| = x$  when  $x > 0$ , and  $|x| = -x$ , when  $x < 0$ . Thus, statement (1) can be rewritten in the following manner:

$$\begin{aligned} |x - x^2| = 2 & \quad \text{when } x^2 > 0 \\ |x - (-x^2)| = 2 & \quad \text{when } x^2 < 0 \quad (\text{BUT } x^2 \text{ is never less than 0;} \\ & \quad \text{this scenario DOES NOT exist)} \end{aligned}$$

We can further simplify the expression into two scenarios:

- I.  $x - x^2 = 2$  when  $x - x^2 > 0$  ( $0 < x < 1$  \*\*)
- II.  $-(x - x^2) = 2$  or  $x^2 - x = 2$  when  $x - x^2 < 0$  ( $x < 0$  or  $x > 1$  \*\*)

Scenario I can be rewritten as  $x^2 - x + 2 = 0$ . On the GMAT, a quadratic in the form of  $x^2 + bx + c = 0$  can be factored by finding which two factors of  $c$  (including negative factors) add up to  $b$ , paying special attention to the sign of  $b$  and  $c$ . There are no such factors in this equation (neither 1,2 nor -1,-2 add up to -1); therefore the quadratic cannot be factored and there are no integer solutions here. Alternatively, you can use the quadratic formula to see that this quadratic has no *real* solutions because if we compare this quadratic to the standard form of a quadratic  $ax^2 + bx + c = 0$ , we see that  $a = 1$ ,  $b = -1$ , and  $c = 2$ . For any quadratic to have real roots, the expression  $b^2 - 4ac$  must be positive, and in this case it is not:  $(-1)^2 - 4(1)(2) = -7$ .

Scenario II can be rewritten as  $x^2 - x - 2 = 0$ . This quadratic can be factored:  $(x - 2)(x + 1) = 0$ , with solutions  $x = -1$  or  $2$ . Notice that these two solutions are consistent with the conditions for this scenario, namely  $x < 0$  or  $x > 1$ . It is important to always check potential solutions to an absolute value expression against the conditions that defined that scenario. Whenever a certain scenario for an absolute value expression yields an answer *that violates the very condition that defined that scenario*, that answer is null and void. Scenario II therefore yields two solutions,  $x = -1$  or  $2$ , so statement (1) is insufficient.

Statement (2),  $|x^2 - |x|| = 2$  can first be rewritten using the following two scenarios:

- III.  $|x^2 - x| = 2$  when  $x > 0$
- IV.  $|x^2 - (-x)| = 2$  or  $|x^2 + x| = 2$  when  $x < 0$

Furthermore each of these scenarios has two scenarios:

- IIIA.  $x^2 - x = 2$  when  $x^2 - x > 0$  ( $x < 0$  or  $x > 1$  \*\*)
- IIIB.  $-(x^2 - x) = 2$  or  $x - x^2 = 2$  when  $x^2 - x < 0$  ( $0 < x < 1$  \*\*)
- IVA.  $x^2 + x = 2$  when  $x^2 + x > 0$  ( $x < -1$  or  $x > 0$  \*\*)
- IVB.  $-(x^2 + x) = 2$  or  $-x^2 - x = 2$  when  $x^2 + x < 0$  ( $-1 < x < 0$  \*\*)

Notice that these four scenarios are subject to their specific conditions, as well as to the general conditions for scenarios I and II above ( $x > 0$  or  $x < 0$ , respectively)

Scenario IIIA can be rewritten as  $x^2 - x - 2 = 0$  or  $(x - 2)(x + 1) = 0$ , so it has two solutions,  $x = -1$ ,  $2$ . HOWEVER, one of these solutions,  $x = -1$ , *violates the condition* for all scenario I's which says that  $x > 0$ . Therefore, according to scenario IA there is only one solution,  $x = 2$ .

Scenario IIIB can be rewritten as  $x^2 - x + 2 = 0$ , which offers no integer solutions (see above).

Scenario IVA can be rewritten as  $x^2 + x - 2 = 0$  or  $(x + 2)(x - 1) = 0$ , so it has two solutions,  $x = -2$ ,  $1$ . HOWEVER, one of these solutions,  $x = 1$ , *violates the condition* for all scenario II's which says that  $x < 0$ . Therefore, according to scenario IIA there is only one solution,  $x = -2$ .

Scenario IVB can be rewritten as  $x^2 + x + 2 = 0$ , which offers no integer solutions (see above).

Taking all four scenarios of statement (2) into account (IIIA, IIIB, IVA, IVB),  $x = -2, 2$ , so statement (2) is NOT sufficient.

When you take statements (1) and (2) together,  $x$  must be 2 so the answer is C.

An alternative, easier approach to this problem would be to set up the different scenarios WITHOUT concentrating on the conditions. Whatever solutions you come up with could then be verified by plugging them back into the appropriate equation. For example, in scenario IIIA of statement (2), the  $x = -1$  could have been eliminated as a possible answer choice by simply trying it back in the equation  $|x^2 - |x|| = 2$ . We discovered the *reason* why it doesn't work above – it violates one of the conditions for the scenario. However, often times the *reason* is of little significance on the GMAT.

\*\* The above conditions were simplified in the following manner:

For example  $x - x^2 > 0$  implies that  $x(1 - x) > 0$ . We can use the solutions to the "parallel" quadratic  $x(1 - x) = 0$ , i.e.  $x = 0$  or  $1$ , to help us think about the inequality. The solutions to the corresponding quadratic must be the endpoints of the ranges that are the solution to the inequality. Just try numbers in these various

ranges: less than 0 (e.g. -1), in between 0 and 1 (e.g.  $\frac{1}{2}$ ) and greater than 1 (e.g. 2). In this

case only the  $\frac{1}{2}$  satisfies the expression  $x - x^2 > 0$ , so the condition here is

$$0 < x < 1.$$

### 70.

From 1,  $n+1 > 0$ ,  $n > -1$ .  $n$  is an integer, so,  $n \geq 0$

From 2,  $np > 0$ .

Combined 1 and 2,  $p > 0$

Answer is C

### 71.

The first step we need to take is to simplify the left side of the inequality:

$$\begin{aligned} & \left( \frac{a-b}{a^{-1}+b^{-1}} \right)^{-1} \rightarrow \\ & \frac{a^{-1}+b^{-1}}{a-b} \rightarrow \\ & \frac{\left( \frac{1}{a} + \frac{1}{b} \right)}{(a-b)} \rightarrow \\ & \frac{\left( \frac{a+b}{ab} \right)}{(a-b)} \rightarrow \\ & \frac{(a+b)}{(ab)(a-b)} \end{aligned}$$

We can now rephrase the question as "Is  $\frac{(a+b)}{(ab)(a-b)} > (a+b)$ ?"

Statement (1) tells us that the absolute value of  $a$  is greater than the absolute value of  $b$ . Immediately we need to consider whether different sets of values for  $a$  and  $b$  would yield different answers.

Since the question deals with absolute value and inequalities, it is wise to select values to cover multiple bases. That is, choose sets of values to take into account different combinations of positive and negative, fraction and integer, for example.

Let's first assume that  $a$  and  $b$  are positive integers. Let  $a$  equal 4 and  $b$  equal 2, since the absolute value of  $a$  must be greater than that of  $b$ . If we plug these values into the inequality, we get 3/8 on the left and 6 on the right, yielding an answer of "no" to the question.

Now let's assume that  $a$  and  $b$  are negative integers. Let  $a$  equal -4 and  $b$  equal -2, since the absolute value of  $a$  must be greater than that of  $b$ . If we plug these values into the inequality, we get 3/8 on the left and -6 on the right, yielding an answer of "yes" to the question.

Since statement (1) yields both "yes" and "no" depending on the values chosen for  $a$  and  $b$ , it is insufficient.

Statement (2) tells us that  $a$  is less than  $b$ . Again, we should consider whether different sets of values for  $a$  and  $b$  would yield different answers.

Let's assume that  $a$  and  $b$  are negative integers. Let  $a$  equal -4 and  $b$  equal -2, since  $a$  must be less than  $b$ . If we plug these values into the inequality, we get 3/8 on the left and -6 on the right, yielding an answer of "yes" to the question.

Now let's assume that  $a$  is a negative fraction and that  $b$  is a positive fraction. Let  $a$  equal -1/2 and  $b$  equal 1/5. If we plug these values into the inequality, we get 30/7 on the left and on the right we get -3/10, yielding an answer of "no" to the question.

Do not forget that if a question does not specify that an unknown is an integer you CANNOT assume that it is. In fact, you must ask yourself whether the distinction between integer and fraction makes any difference in the question.

Since statement (2) yields both "yes" and "no" depending on the values chosen for  $a$  and  $b$ , it is insufficient.

Now we must consider the information from the statements taken together. From both statements, we know that the absolute value of  $a$  is greater than that of  $b$  and that  $a$  is less than  $b$ . If  $a$  equals  $-4$  and  $b$  equals  $-2$ , both statements are satisfied and we can answer "yes" to the question. However, if  $a$  equals  $-1/2$  and  $b$  equals  $1/5$ , both statements are also satisfied but we can answer "no" to the question.

Even pooling the information from both statements, the question can be answered either "yes" or "no" depending on the values chosen for  $a$  and  $b$ . The statements in combination are therefore insufficient.

The correct answer is E: Statements (1) and (2) together are not sufficient.

### 72.

For  $|a| + |b| > |a + b|$  to be true,  $a$  and  $b$  must have opposite signs. If  $a$  and  $b$  have the same signs (i.e. both positive or both negative), the expressions on either side of the inequality will be the same. The question is really asking if  $a$  and  $b$  have opposite signs.

(1) INSUFFICIENT: This tells us that  $|a| > |b|$ . This implies nothing about the signs of  $a$  and  $b$ .

(2) INSUFFICIENT: Since the absolute value of  $a$  is always positive, this tells us that  $b < 0$ . Since we don't know the sign of  $a$ , we can't answer the question.

(1) AND (2) INSUFFICIENT: We know the sign of  $b$  from statement 2 but statement 1 does not tell us the sign of  $a$ . For example, if  $b = -4$ ,  $a$  could be 5 or  $-5$ .

The correct answer is E

### 73.

In order to answer the question, Is  $\sqrt{x}$  a prime number?, we must first solve for  $x$ .

The key to solving this week's problem is understanding that certain types of equations have more than one solution.

One such equation type, is an equation that involves absolute value, like the equation in the first statement. Let's solve for  $x$  in statement one.

The first solution to an absolute value equation assumes that the expression inside the brackets yields a positive result (and therefore the absolute value brackets do not actually change the sign of this expression).

$$|3x - 7| = 2x + 2$$

$$3x - 7 = 2x + 2$$

$$x - 7 = 2$$

$$x = 9$$

Notice that in the "positive" version of the absolute value equation, we simply remove the absolute value brackets with no change to the expression inside.

The second solution to an absolute value equation assumes that the expression inside the brackets yields a negative result (and therefore the absolute value brackets DO change the sign of this expression from negative to positive).

$$|3x - 7| = 2x + 2$$

$$-3x + 7 = 2x + 2$$

$$7 = 5x + 2$$

$$5 = 5x$$

$$1 = x$$

Notice that in the "negative" version of the absolute value equation, when we remove the absolute value brackets, we must reverse the sign of all the terms inside.

Thus, according to statement 1,  $x$  may be 1 or 9. From this, we know that  $\sqrt{x}$  must be 1 or 3. Since 1 is not a prime number, but 3 is a prime number, it is NOT possible to answer the original question using statement one, alone.

Now let's analyze statement two ( $x^2 = 9x$ ) alone. Although it may be tempting to simply divide both sides of this equation by  $x$ , and find that  $x = 9$ , this neglects an important second solution.

We must first realize that statement two is a quadratic equation. Generally, quadratic equations have two solutions. To see this, let's rewrite this equation in quadratic form and then factor as follows:

$$x^2 = 9x$$

$$x^2 - 9x = 0$$

$$x(x - 9) = 0$$

Factoring produces two solutions:

Either  $x = 0$  or  $x - 9 = 0$ . Thus,  $x$  can be

0 or 9.

Thus, according to statement two,  $x$  may be 0 or 9. From this, we know that  $\sqrt{x}$  must be 0 or 3. Since 0 is not a prime number, but 3 is a prime number, it is NOT possible to answer the original question using statement two, alone.

Now let's analyze both statements together. From statement one, we know that  $x$  must be 1 or 9. From statement two, we know that  $x$  must be 0 or 9. Thus, since both statements must be true, we can deduce that  $x$  must be 9.

Therefore  $\sqrt{x} = 3$ , which is a prime number. Using both statements, we can answer the question in the affirmative: Yes,  $\sqrt{x}$  is a prime number.

Since BOTH statements TOGETHER are sufficient, but NEITHER statement ALONE is sufficient, the correct answer is C.

#### 74.

The question asks for the average of  $x$  and  $|y|$ . Taking the absolute value of a number has no effect if that number is positive; on the other hand, taking the absolute value of a negative number changes the sign to positive. The most straightforward way to approach this question is to test positive and negative values for  $y$ .

(1) INSUFFICIENT: We know that the sum of  $x$  and  $y$  is 20. Here are two possible scenarios, yielding different answers to the question:

$x$	$y$	Sum	Average of $x$ and $ y $
10	10	20	10
25	-5	20	15

(2) INSUFFICIENT: We know that  $|x + y| = 20$ . The same scenarios listed for statement (1) still apply here. There is more than one possible value for the average of  $x$  and  $|y|$ ,

(1) AND (2) INSUFFICIENT: We *still* have the same scenarios listed above. Since there is more than one possible value for the average of  $x$  and  $|y|$ , both statements taken together are NOT sufficient.

The correct answer is E.

**75.**

First, let's simplify the question:

$$(x^{-1} + y^{-1})^{-1} > ((x^{-1})(y^{-1}))^{-1}$$

$$\left(\frac{1}{x} + \frac{1}{y}\right)^{-1} > \left(\left(\frac{1}{x}\right)\left(\frac{1}{y}\right)\right)^{-1}$$

$$\left(\frac{x+y}{xy}\right)^{-1} > \left(\frac{1}{xy}\right)^{-1}$$

$$\text{Is } \frac{xy}{x+y} > xy ?$$

(1) SUFFICIENT: If we plug  $x = 2y$  into our simplified question we get the following:

Is  $2y^2/3y > 2y^2$ ? Since  $2y^2$  must be positive we can divide both sides of the inequality by  $2y^2$  which leaves us with the following: Is  $1/3y > 1$ ? If we investigate this carefully, we find that if  $y$  is a nonzero integer,  $1/3y$  is never greater than 1. Try  $y = 2$  and  $y = -2$ , In both cases  $1/3y$  is less than 1.

(2) INSUFFICIENT: Let's plug in values to investigate this statement. According to this statement, the  $x$  and  $y$  values we choose must have a positive sum. Let's choose a set of values that will yield a positive  $xy$  and a set of values that will yield a negative  $xy$ .

$x$	$y$	
3	1	$xy/(x + y) < xy$
3	-1	$xy/(x + y) > xy$

This not does yield a definitive yes or no answer so statement (2) is not sufficient.

The correct answer is A.

**76.**

The question can first be rewritten as "Is  $p(pq) > q(pq)$ ?"

If  $pq$  is positive, we can divide both sides of the inequality by  $pq$  and the question then becomes: "Is  $p > q$ ?"

If  $pq$  is negative, we can divide both sides of the inequality by  $pq$  and change the direction of the inequality sign and the question becomes: "Is  $p < q$ ?"

Since Statement 2 is less complex than Statement 1, begin with Statement 2 and a BD/ACE grid.

(1) INSUFFICIENT: Knowing that  $pq < 0$  means that the question becomes "Is  $p < q$ ?" We know that  $p$  and  $q$  have opposite signs, but we don't know which one is positive and which one is negative so we can't answer the question "Is  $p < q$ ?"

(2) INSUFFICIENT: We know nothing about  $q$  or its sign.

(1) AND (2) SUFFICIENT: From statement (1), we know we are dealing with the question "Is  $p < q$ ?" and that  $p$  and  $q$  have opposite signs. Statement (2) tells us that  $p$  is negative, which means that  $q$  is positive. Therefore  $p$  is in fact less than  $q$ .  
The correct answer is C.

**77.**

We can rephrase the question: "Is  $m - n > 0$ ?"

(1) INSUFFICIENT: If we solve this inequality for  $m - n$ , we get  $m - n < 2$ . This does not answer the question "Is  $m - n > 0$ ?"

(2) SUFFICIENT: If we solve this inequality for  $m - n$ , we get  $m - n < -2$ . This answers the question "Is  $m - n > 0$ ?" with an absolute NO.

The correct answer is B.

**78.**

Since Statement 2 is less complex than Statement 1, begin with Statement 2 and a BD/ACE grid.

(1) INSUFFICIENT: We can substitute  $2p$  for  $q$  in the inequality in the question:  $3^p > 2^{2p}$ . This can be simplified to  $3^p > (2^2)^p$  or  $3^p > 4^p$ .

If  $p > 0$ ,  $3^p < 4^p$  (for example  $3^2 < 4^2$  and  $3^{0.5} < 4^{0.5}$ )

If  $p < 0$ ,  $3^p > 4^p$  (for example  $3^{-1} > 4^{-1}$ )

Since we don't know whether  $p$  is positive or negative, we cannot tell whether  $3^p$  is greater than  $4^p$ .

(2) INSUFFICIENT: This tells us nothing about  $p$ .

(1) AND (2) SUFFICIENT: If  $q > 0$ , then  $p$  is also greater than zero since  $p = 2q$ . If  $p > 0$ , then  $3^p < 4^p$ . The answer to the question is a definite NO.

The correct answer is C.

**79.**

To begin, list all of the scenarios in which  $mp$  would be greater than  $m$ . There are only 2 scenarios in which this would occur.

Scenario 1:  $m$  is positive and  $p$  is greater than 1 (since a fractional or negative  $p$  will shrink  $m$ ).

Scenario 2:  $m$  is negative and  $p$  is less than 1 -- in other words,  $p$  can be a positive fraction, 0 or any negative number. A negative value for  $p$  will make the product positive, 0 will make it 0 and a positive fraction will make a negative  $m$  greater).

NOTE: These scenarios could have been derived algebraically by solving the inequality  $mp > m$ :

$$mp - m > 0$$

$$m(p - 1) > 0$$

Which means either  $m > 0$  and  $p > 1$  OR  $m < 0$  and  $p < 1$ .

(1) INSUFFICIENT: This eliminates the second scenario, but doesn't guarantee the first scenario.

If  $m = 100$  and  $p = .5$ , then  $mp = 50$ , which is NOT greater than  $m$ . On the other hand, if  $m = 100$  and  $p = 2$ , then  $mp = 200$ , which IS greater than  $m$ .

(2) INSUFFICIENT: This eliminates the first scenario since  $p$  is less than 1, but it doesn't guarantee the second scenario.  $m$  has to be negative for this to always be true. If  $m = -100$  and  $p = -2$ , then  $mp = 200$ , which IS greater than  $m$ . But if  $m = 100$  and  $p = .5$ , then  $mp = 50$ , which is NOT greater than  $m$ .

(1) AND (2) SUFFICIENT: Looking at statements (1) and (2) together, we know that  $m$  is positive and that  $p$  is less than 1. This contradicts the first and second scenarios, thereby ensuring that  $mp$  will NEVER be greater than  $m$ . Thus, both statements together are sufficient to

answer the question. Note that the answer to the question is "No" -- which is a definite, and therefore sufficient, answer to a "Yes/No" question in Data Sufficiency.  
The correct answer is C.

**80.**

In order to answer the question, we must compare  $w$  and  $y$ .

(1) INSUFFICIENT: This provides no information about  $y$ .

(2) INSUFFICIENT: This provides no information about  $w$ .

(1) AND (2) INSUFFICIENT: Looking at both statements together, it is possible that  $w$  could be less than  $y$ . For example  $w$  could be 1.305 and  $y$  could be 100. It is also possible that  $w$  could be greater than  $y$ . For example,  $w$  could be 1.310 and  $y$  could be 1.305. Thus, it is not possible to determine definitively whether  $w$  is less than  $y$ .

The correct answer is E.

# NUMBERS

## Types of Numbers

1.

We cannot rephrase the given question so we will proceed directly to the statements.

(1) INSUFFICIENT:  $n$  could be divisible by any square of a prime number, e.g. 4 ( $2^2$ ), 9 ( $3^2$ ), 25 ( $5^2$ ), etc.

(2) INSUFFICIENT: This gives us no information about  $n$ . It is not established that  $y$  is an integer, so  $n$  could be many different values.

(1) AND (2) SUFFICIENT: We know that  $y$  is a prime number. We also know that  $y^4$  is a two-digit odd number. The only prime number that yields a two-digit *odd* integer when raised to the fourth power is 3:  $3^4 = 81$ . Thus  $y = 3$ .

We also know that  $n$  is divisible by the square of  $y$  or 9. So  $n$  is divisible by 9 and is less than 99, so  $n$  could be 18, 27, 36, 45, 54, 63, 72, 81, or 90. We do not know which number  $n$  is but we do know that all of these two-digit numbers have digits that sum to 9. The correct answer is C.

2.

When we take the square root of any number, the result will be an integer only if the

original number is a perfect square. Therefore, in order for  $\sqrt{x+y}$  to be an integer, the quantity  $x+y$  must be a perfect square. We can rephrase the question as "Is  $x+y$  a perfect square?"

(1) INSUFFICIENT: If  $x^3 = 64$ , then we take the cube root of 64 to determine that  $x$  must equal 4. This tells us nothing about  $y$ , so we cannot determine whether  $x+y$  is a perfect square.

(2) INSUFFICIENT: If  $x^2 = y - 3$ , then we can rearrange to  $x^2 - y = -3$ . There is no way to rearrange this equation to get  $x+y$  on one side, nor is there a way to find  $x$  and  $y$  separately, since we have just one equation with two variables.

(1) AND (2) SUFFICIENT: Statement (1) tells us that  $x = 4$ . We can substitute this into the equation given in statement two:  $4^2 = y - 3$ . Now, we can solve for  $y$ .  $16 = y - 3$ , therefore  $y = 19$ .  $x + y = 4 + 19 = 23$ . The quantity  $x+y$  is not a perfect square. Recall that "no" is a definitive answer; it is sufficient to answer the question.

The correct answer is C.

3.

The least number in the list is -4, so, the list contains -4, -3, -2, -1, 0, 1, 2, 3, 4, 5, 6, 7.

So, the range of the positive integers is  $7 - 1 = 6$ .

4. Since  $x$  is the sum of six consecutive integers, it can be written as:

$$x = n + (n + 1) + (n + 2) + (n + 3) + (n + 4) + (n + 5)$$

$$x = 6n + 15$$

Note that  $x$  must be odd since it is the sum of the even term  $6n$  and the odd term 15, and an even plus an odd gives an odd.

I. TRUE: Since  $6n$  and 15 are both divisible by 3,  $x$  is divisible by 3.

II. FALSE: Since  $x$  is odd, it CANNOT be divisible by 4.

III. FALSE: Since  $x$  is odd, it CANNOT be divisible by 6.

The correct answer is A.

**5.**

If the least number was 3, then  $3*4=12 < 15$ , does not fulfill the requirement. So, the least number is 4.

If the greatest number is 14, then  $14*15=210 > 200$ , does not fulfill the requirement. So, answer is "4 and 13"

**6.**

From statement 1,  $p/4=n$ ,  $n$  is prime number, could be 2, 3, 5, 7, 11, ... insufficient.

From statement 2,  $p/3=n$ ,  $n$  is an integer, could be 1, 2, 3, 4, 5, ... insufficient.

Combined 1 and 2, only when  $p=12$  can fulfill the requirement.

Answer is C.

**7.**

In order for  $\frac{ab}{cd}$  to be positive,  $ab$  and  $cd$  must share the same sign; that is, both either positive or negative.

There are two sets of possibilities for achieving this sufficiency. First, if all four integers share the same sign- positive or negative- both  $ab$  and  $cd$  would be positive. Second, if any two of the four integers are positive while the other two are negative,  $ab$  and  $cd$  must share the same sign. The following table verifies this claim:

Positive Pair	Negative Pair	$ab$ Sign	$cd$ Sign
$a, b$	$c, d$	+	+
$a, c$	$b, d$	-	-
$a, d$	$b, c$	-	-
$b, c$	$a, d$	-	-
$b, d$	$a, c$	-	-
$c, d$	$a, b$	+	+

For the first and last cases,  $\frac{ab}{cd}$  will be positive. On the other hand, it can be shown that if only one of the four

integers is positive and the other three negative, or vice versa,  $\frac{ab}{cd}$  must be negative. This question can most tidily be rephrased as "Among the integers  $a, b, c$  and  $d$ , are an even number (zero, two, or all four) of the integers positive?"

(1) SUFFICIENT: This statement can be rephrased as  $ad = -bc$ . For the signs of  $ad$  and  $bc$  to be opposite one another, either precisely one or three of the four integers must be negative. The answer to our rephrased question is "no," and, therefore, we have achieved sufficiency.

(2) SUFFICIENT: For the product  $abcd$  to be negative, either precisely one or three of the four integers must be negative. The answer to our rephrased question is "no," and, therefore, we have achieved sufficiency.

The correct answer is D.

**8.**

- 1)  $J = 2 * 3 * 5 \Rightarrow J$  has 3 different prime factors, insufficient.
  - 2)  $K = 2^3 * 5^3 \Rightarrow K$  has 2 different prime factors, insufficient.
  - $1 + 2 \Rightarrow J$  has more different prime factors
- Answer is C

**9.**

A-----9-----C-----8-----D--1--B  
 A--1--D--8-----C-----9-----B  
 Both the two situations can fulfill the requirements.  
 Answer is E

**10.**

Statement 1: the greatest number\*the least number is positive, means all the numbers should be positive or negative.  
 All are positive integers, the product of all integers is positive.  
 All are negative integers, we need to know even or odd the number of the integers is.  
 From 2, we know the number of the integers is even. Thus, the product is positive.  
 Answer is C

**11.** For statement 1, for example, 0, 0, 0, 2 can fulfill the requirement. Insufficient. So, B

**12.**

For 1,  $3*2 > 3$ , \* can be multiply or add, while  $(6*2)*4 = 6*(2*4)$ .  
 For 2,  $3*1 = 3$ , \* can be multiply or divide. The information cannot determine whether  $(6*2)*4 = 6*(2*4)$ .  
 Answer is A

**13.**

$x+4=1, y+4=-5 \Rightarrow x=-3, y=-9, z+4=m$   
 $x+e=7, y+e=n \Rightarrow e=10, n=1, z=0, z+e=10$   
 $z=0$  and  $z+4=m, m=4 \Rightarrow m+n=4+1=5$

## ODDS and EVENS

1.

(1) SUFFICIENT: If  $z/2 = \text{even}$ , then  $z = 2 \times \text{even}$ . Thus,  $z$  must be even, because it is the product of 2 even numbers.

Alternatively, we could list numbers according to the criteria that  $z/2$  is even.

$z/2$ : 2, 4, 6, 8, 10, etc.

Multiply the entire list by the denominator 2 to isolate the possible values of  $z$ :

$z$ : 4, 8, 12, 16, 20, etc. All of those values are even.

(2) INSUFFICIENT: If  $3z = \text{even}$ , then  $z = \text{even}/3$ . There are no odd and even rules for division, mainly because there is no guarantee that the result will be an integer. For example, if  $3z = 6$ , then  $z$  is the even integer 2. However, if  $3z = 2$ , then  $z = 2/3$ , which is not an integer at all.

The danger in evaluating this statement is forgetting about the fractional possibilities. A way to avoid that mistake is to create a full list of numbers for  $z$  that meet the criteria that  $3z$  is even.

$3z$ : 2, 4, 6, 8, 10, 12, etc.

Divide the entire list by the coefficient 3 to isolate the possible values of  $z$ :

$z$ :  $2/3$ ,  $4/3$ , 2,  $8/3$ ,  $10/3$ , 4, etc. Some of those values are even, but others are not.

The correct answer is A.

2. (1) INSUFFICIENT: Given that  $m = p^2 + 4p + 4$ ,

If  $p$  is even:

$$m = (\text{even})^2 + 4(\text{even}) + 4$$

$$m = \text{even} + \text{even} + \text{even}$$

$$m = \text{even}$$

If  $p$  is odd:

$$m = (\text{odd})^2 + 4(\text{odd}) + 4$$

$$m = \text{odd} + \text{even} + \text{even}$$

$$m = \text{odd}$$

Thus we don't know whether  $m$  is even or odd. Additionally, we know nothing about  $n$ .

(2) INSUFFICIENT: Given that  $n = p^2 + 2m + 1$

If  $p$  is even:

$$n = (\text{even})^2 + 2(\text{even or odd}) + 1$$

$$n = \text{even} + \text{even} + \text{odd}$$

$$n = \text{odd}$$

If  $p$  is odd:

$$n = (\text{odd})^2 + 2(\text{even or odd}) + 1$$

$$n = \text{odd} + \text{even} + \text{odd}$$

$$n = \text{even}$$

Thus we don't know whether  $n$  is even or odd. Additionally, we know nothing about  $m$ .

(1) AND (2) SUFFICIENT: If  $p$  is even, then  $m$  will be even and  $n$  will be odd. If  $p$  is odd, then  $m$

will be odd and  $n$  will be even. In either scenario,  $m + n$  will be odd.

The correct answer is C.

**3.**

We can first simplify the exponential expression in the question:

$$b^{a+1} - ba^b$$

$$b(b^a) - b(a^b)$$

$$b(b^a - a^b)$$

So we can rewrite this question then as is  $b(b^a - a^b)$  odd? Notice that if either  $b$  or  $b^a - a^b$  is even, the answer to this question will be no.

(1) SUFFICIENT: If we simplify this expression we get  $5a - 8$ , which we are told is odd. For the difference of two numbers to be odd, one must be odd and one must be even. Therefore  $5a$  must be odd, which means that  $a$  itself must be odd. To determine whether or not this is enough to dictate the even/oddness of the expression  $b(b^a - a^b)$ , we must consider two scenarios, one with an odd  $b$  and one with an even  $b$ :

$a$	$b$	$b(b^a - a^b)$	odd/even
3	1	$1(1^3 - 3^1) = -2$	even
3	2	$2(2^3 - 3^2) = -2$	even

It turns out that for both scenarios, the expression  $b(b^a - a^b)$  is even.

(2) SUFFICIENT: It is probably easiest to test numbers in this expression to determine whether it implies that  $b$  is odd or even.

$b$	$b^3 + 3b^2 + 5b + 7$	odd/even
2	$2^3 + 3(2^2) + 5(2) + 7 = 37$	odd
1	$1^3 + 3(1^2) + 5(1) + 7 = 16$	even

We can see from the two values that we plugged that only even values for  $b$  will produce odd values for the expression  $b^3 + 3b^2 + 5b + 7$ , therefore  $b$  must be even. Knowing that  $b$  is even tells us that the product in the question,  $b(b^a - a^b)$ , is even so we have a definitive answer to the question.

The correct answer is D, EACH statement ALONE is sufficient to answer the question.

**4.**

The question asks simply whether  $x$  is odd. Since we cannot rephrase the question, we must go straight to the statements.

(1) INSUFFICIENT: If  $y$  is even, then  $y^2 + 4y + 6$  will be even, since every term will be even. For example, if  $y = 2$ , then  $y^2 + 4y + 6 = 4 + 8 + 6 = 18$ . But if  $y$  is odd, then  $y^2 + 4y + 6$  will be odd. For example, if  $y = 3$ , then  $y^2 + 4y + 6 = 9 + 12 + 6 = 27$ .

(2) SUFFICIENT: If  $z$  is even, then  $9z^2 + 7z - 10$  will be even. For example, if  $z = 2$ , then  $9z^2 + 7z - 10 = 36 + 14 - 10 = 40$ . If  $z$  is odd, then  $9z^2 + 7z - 10$  will still be even. For example, if  $z = 3$ , then  $9z^2 + 7z - 10 = 81 + 21 - 10 = 92$ . So no matter what the value of  $z$ ,  $x$  will be even and we can answer "no" to the original question.

The correct answer is B.

**5.**

First, let's simplify the inequality in the original question:

$$3x + 5 < x + 11$$

$$2x < 6$$

$$x < 3$$

Since  $x$  is less than 3 and must be a positive integer, the only way that  $x$  can be a prime number is when  $x = 2$ . Therefore, we can rephrase the question: "Does  $x$  equal 2?"

(1) INSUFFICIENT: We can infer from this statement that  $x$  and  $y$  are either both even or both odd. Since we do not have any information about the value of  $y$ , we cannot determine the value of  $x$ .

(2) SUFFICIENT: Since the product of  $x$  and  $y$  is odd, we know that  $x$  and  $y$  are both odd. Therefore,  $x$  cannot be a prime number, since the only prime number less than 3 is 2, i.e. an even number. Thus, since  $x$  is odd, we know that it is not a prime, and this statement is sufficient to yield a definitive answer "no" to the main question.

The correct answer is B.

6.

This question asks simply whether the positive integer  $p$  is even. This question cannot be rephrased.

(1) INSUFFICIENT:  $p^2 + p$  can be factored, resulting in  $p(p + 1)$ . This expression equals the product of two consecutive integers and we are told that this product is even. In order to make the product even, either  $p$  or  $p + 1$  must be even, so  $p(p + 1)$  will be even regardless of whether  $p$  is odd or even. Alternatively, we can try numbers. For  $p = 2$ ,  $2(2 + 1) = 6$ . For  $p = 3$ ,  $3(3 + 1) = 12$ . So, when  $p(p + 1)$  is even,  $p$  can be even or odd.

(2) INSUFFICIENT: Multiplying any positive integer  $p$  by 4 (an even number) will always result in an even number. Adding an even number to an even number will always result in an even number. Therefore,  $4p + 2$  will always be even, regardless of whether  $p$  is odd or even. Alternatively, we can try numbers. For  $p = 2$ ,  $4(2) + 2 = 10$ . For  $p = 3$ ,  $4(3) + 2 = 14$ . So, when  $4p + 2$  is even,  $p$  can be even or odd.

(1) AND (2) INSUFFICIENT: Because both statements (1) and (2) are true for all positive integers, combining the two statements is insufficient to determine whether  $p$  is even. Alternatively, notice that for each statement, we tried  $p = 2$  and  $p = 3$ . We can also use these two numbers when we combine the two statements and we are left with the same result:  $p$  can be even or odd.

The correct answer is E

7.

First, let us simplify the original expression:  $p + q + p = 2p + q$

Since the product of an even number and any other integer will always be even, the value of  $2p$  must be even. If  $q$  were even,  $2p + q$  would be the sum of two even integers and would thus have to be even. But the problem stem tells us that  $2p + q$  is odd. Therefore,  $q$  cannot be even, and must be odd.

Alternatively, we can reach this same conclusion by testing numbers. We simply test even and odd values of  $p$  and  $q$  to see whether they meet our condition that  $p + q + p$  must be odd.

1) even + even + even = even (for example,  $4 + 2 + 4 = 10$ ). The combination ( $p$  even,  $q$  even) does **not** meet our condition.

2) odd + odd + odd = odd (for example,  $5 + 3 + 5 = 13$ ). The combination ( $p$  odd,  $q$  odd) **does** meet our condition.

3) even + odd + even = odd (for example,  $4 + 3 + 4 = 11$ ). The combination ( $p$  even,  $q$  odd) **does** meet our condition.

4) odd + even + odd = even (for example,  $3 + 4 + 3 = 10$ ). The combination ( $p$  odd,  $q$  even) does **not** meet our condition.

If we examine our results, we see that  $q$  has to be odd, while  $p$  can be either odd or even. Our question asks us which answer must be odd; since  $q$  is an answer choice, we don't have to test the more complicated answer choices.

The correct answer is B.

8.

If  $ab^2$  were odd, the quotient would never be divisible by 2, regardless of what  $c$  is. To prove this try to divide an odd number by any integer to come up with an even number; you can't. If  $ab^2$  is even, either  $a$  is even or  $b$  is even.

(I) TRUE: Since  $a$  or  $b$  is even, the product  $ab$  must be even

(II) NOT NECESSARILY: For the quotient to be positive,  $a$  and  $c$  must have the same sign since  $b^2$  is definitely positive. We know nothing about the sign of  $b$ . The product of  $ab$  could be negative or positive.

(III) NOT NECESSARILY: For the quotient to be even,  $ab^2$  must be even but  $c$  could be even or odd. An even number divided by an odd number could be even (ex:  $18/3$ ), as could an even number divided by an even number (ex:  $16/4$ ).

The correct answer is A.

9.

Since the digits of  $G$  are halved to derive those of  $H$ , the digits of  $G$  must both be even.

Therefore, there are only 16 possible values for  $G$  and  $H$  and we can quickly calculate the possible sums of  $G$  and  $H$ :

$G$	$H$	$G + H$
88	44	132
86	43	129
84	42	126
82	41	123
68	34	102
66	33	99
64	32	96
62	31	93
48	24	72
46	23	69
44	22	66
42	21	63
28	14	42
26	13	39
24	12	36
22	11	33

Alternately, we can approach this problem algebraically. Let's call  $x$  and  $y$  the tens digit and the units digit of  $G$ . Thus  $H$  can be expressed as  $5x + .5y$ . And the sum of  $G$  and  $H$  can be written as  $15x + 1.5y$ .

Since we know that  $x$  and  $y$  must be even, we can substitute  $2a$  for  $x$  and  $2b$  for  $y$  and can rewrite the expression for the sum of  $G$  and  $H$  as:  $15(2a) + 1.5(2b) = 30a + 3b$ . This means that the sum of  $G$  and  $H$  must be divisible by 3, so we can eliminate C and E.

Additionally, since we know that the maximum value of  $G$  is less than 100, then the maximum

value of H must be less than 50. Therefore the maximum value of G + H must be less than 150. This eliminates answer choices A and B. This leaves answer choice D, 129. This can be written as 86 + 43.

The correct answer is D.

**10.**

Let's look at each answer choice:

(A) EVEN: Since  $a$  is even, the product  $ab$  will always be even. Ex:  $2 \times 7 = 14$ .

(B) UNCERTAIN: An even number divided by an odd number might be even if the the prime factors that make up the odd number are also in the prime box of the even number. Ex:  $6/3 = 2$ .

(C) NOT EVEN: An odd number is never divisible by an even number. By definition, an odd number is not divisible by 2 and an even number is. The quotient of an odd number divided by an even number will not be an integer, let alone an even integer. Ex:  $15/4 = 3.75$

(D) EVEN: An even number raised to any integer power will always be even. Ex:  $2^1 = 2$

(E) EVEN: An even number raised to any integer power will always be even. Ex:  $2^3 = 8$

The correct answer is C.

11. Let's look at each answer choice:

(A) UNCERTAIN:  $x$  could be the prime number 2.

(B) UNCERTAIN:  $x$  could be the prime number 2, which when added to another prime number (odd) would yield an odd result. Ex:  $2 + 3 = 5$

(C) UNCERTAIN: Since  $x$  could be the prime number 2, the product  $xy$  could be even.

(D) UNCERTAIN:  $y > x$  and they are both prime so  $y$  must be odd. If  $x$  is another odd prime number, the expression will be: (odd) + (odd)(odd), which equals an even ( $O + O = E$ ).

(E) FALSE:  $2x$  must be even and  $y$  must be odd (since it cannot be the smallest prime number 2, which is also the only even prime). The result is even + odd, which must be odd.

The correct answer is E.

**12.**

Sequence problems are often best approached by charting out the first several terms of the given sequence. In this case, we need to keep track of  $n$ ,  $t_n$ , and whether  $t_n$  is even or odd.

<b>n</b>	<b><math>t_n</math></b>	<b>Is <math>t_n</math> even or odd?</b>
0	$t_n = 3$	Odd
1	$t_1 = 3 + 1 = \mathbf{4}$	Even
2	$t_2 = 4 + 2 = \mathbf{6}$	Even
3	$t_3 = 6 + 3 = \mathbf{9}$	Odd
4	$t_4 = 9 + 4 = \mathbf{13}$	Odd
5	$t_5 = 13 + 5 = \mathbf{18}$	Even
6	$t_6 = 18 + 6 = \mathbf{24}$	Even
7	$t_7 = 24 + 7 = \mathbf{31}$	Odd
8	$t_8 = 31 + 8 = \mathbf{39}$	Odd

Notice that beginning with  $n = 1$ , a pattern of even-even-odd-odd emerges for  $t_n$ .

Thus  $t_n$  is even when  $n = 1, 2 \dots 5, 6 \dots 9, 10 \dots 13, 14 \dots$  etc. Another way of conceptualizing this pattern is that  $t_n$  is even when  $n$  is either

(a) 1 plus a multiple of 4 ( $n = 1, 5, 9, 13$ , etc.) or

(b) 2 plus a multiple of 4 ( $n = 2, 6, 10, 14$ , etc).

From this we see that only Statement (2) is sufficient information to answer the question. If  $n - 1$  is a multiple of 4, then  $n$  is 1 plus a multiple of 4. This means that  $t_n$  is always even.

Statement (1) does not allow us to relate  $n$  to a multiple of 4, since it simply tells us that  $n + 1$  is a multiple of 3. This means that  $n$  could be 2, 5, 8, 11, etc. Notice that for  $n = 2$  and  $n = 5$ ,  $t_n$  is in fact even. However, for  $n = 8$  and  $n = 11$ ,  $t_n$  is odd.

Thus, Statement (2) alone is sufficient to answer the question but Statement (1) alone is not. The correct answer is B.

13.

In order for the square of  $(y + z)$  to be even,  $y + z$  must be even. In order for  $y + z$  to be even, either both  $y$  and  $z$  must be odd or both  $y$  and  $z$  must be even.

(1) SUFFICIENT: If  $y - z$  is odd, then one of the integers must be even and the other must be odd. Thus, the square of  $y + z$  will definitely NOT be even. (Recall that "no" is a sufficient answer to a yes/no data sufficiency question; only "maybe" is insufficient.)

(2) INSUFFICIENT: If  $yz$  is even, then it's possible that both integers are even or that one of the integers is even and the other integer is odd. Thus, we cannot tell, whether the the square of  $y + z$  will be even.

The correct answer is A.

14.

Statement 1,  $m$  and  $n$  could be both odd or one odd, one even. Insufficient.

Statement 2, when  $n$  is odd,  $n^2 + 5$  is even, then  $m + n$  is even,  $m$  is odd; when  $n$  is even,  $n^2 + 5 = \text{odd}$ ,  $m + n$  is odd, then  $m$  is odd. Sufficient.

So, answer is B

### Units digits, factorial powers

1.

When raising a number to a power, the units digit is influenced only by the units digit of that number. For example  $16^2$  ends in a 6 because  $6^2$  ends in a 6.

$17^{27}$  will end in the same units digit as  $7^{27}$ .

The units digit of consecutive powers of 7 follows a distinct pattern:

Power of 7	Ends in a ...
$7^1$	7
$7^2$	9
$7^3$	3
$7^4$	1
$7^5$	7

The pattern repeats itself every four numbers so a power of 27 represents 6 full iterations of the pattern ( $6 \times 4 = 24$ ) with three left over. The "leftover three" leaves us back on a "3," the third member of the pattern 7, 9, 3, 1.

The correct answer is C.

2.

When a number is divided by 10, the remainder is simply the units digit of that number. For example, 256 divided by 10 has a remainder of 6. This question asks for the remainder when an integer power of 2 is divided by 10. If we examine the powers of 2 (2, 4, 8, 16, 32, 64, 128, and 256...), we see that the units digit alternates in a consecutive pattern of 2, 4, 8, 6. To answer this question, we need to know which of the four possible units digits we have with  $2^p$ .

(1) INSUFFICIENT: If  $s$  is even, we know that the product  $rst$  is even and so is  $p$ . Knowing that  $p$  is even tells us that  $2^p$  will have a units digit of either 4 or 6 ( $2^2 = 4$ ,  $2^4 = 16$ , and the pattern continues).

(2) SUFFICIENT: If  $p = 4t$  and  $t$  is an integer,  $p$  must be a multiple of 4. Since every fourth integer power of 2 ends in a 6 ( $2^4 = 16$ ,  $2^8 = 256$ , etc.), we know that the remainder when  $2^p$  is divided by 10 is 6.

The correct answer is B.

3.

The easiest way to approach this problem is to chart the possible units digits of the integer  $p$ . Since we know  $p$  is even, and that the units digit of  $p$  is positive, the only options are 2, 4, 6, or 8.

UNITS DIGIT OF $p$	Units Digit of $p^3$	Units Digit of $p^2$	Units Digits of $p^3 - p^2$
2	8	4	4
4	4	6	8
6	6	6	<b>0</b>
8	2	4	8

Only when the units digit of  $p$  is 6, is the units digit of  $p^3 - p^2$  equal to 0.

The question asks for the units digit of  $p + 3$ . This is equal to  $6 + 3$ , or 9.

The correct answer is D.

4.

For problems that ask for the units digit of an expression, yet seem to require too much computation, remember the Last Digit Shortcut. Solve the problem step-by-step, but recognize that you only need to pay attention to the last digit of every intermediate product. Drop any other digits.

So, we can drop any other digits in the original expression, leaving us to find the units digit of:

$$(4)^{(2x+1)}(3)^{(x+1)}(7)^{(x+2)}(9)^{(2x)}$$

This problem is still complicated by the fact that we don't know the value of  $x$ . In such situations, it is often a good idea to look for patterns. Let's see what happens when we raise the bases 4, 3, 7, and 9 to various powers. For example:  $3^1 = 3$ ,  $3^2 = 9$ ,  $3^3 = 27$ ,  $3^4 = 81$ ,  $3^5 = 243$ , and so on. The units digit of the powers of three follow a pattern that repeats every fourth power: 3, 9, 7, 1, 3, 9, 7, 1, and so on. The patterns for the other bases are shown in the table below:

	Exponent						
Base	1	2	3	4	5	6	Pattern
4	4	6	4	6	4	6	4, 6, repeat
3	3	9	7	1	3	9	3, 9, 7, 1, repeat
7	7	9	3	1	7	9	7, 9, 3, 1, repeat
9	9	1	9	1	9	1	9, 1, repeat

The patterns repeat at least every fourth term, so let's find the units digit of  $(4)^{(2x+1)}(3)^{(x+1)}(7)^{(x+2)}(9)^{(2x)}$  for at least four consecutive values of  $x$ :

$x = 1$ : units digit of  $(4^3)(3^2)(7^3)(9^2) =$  units digit of  $(4)(9)(3)(1) =$  units digit of  $108 = 8$

$x = 2$ : units digit of  $(4^5)(3^3)(7^4)(9^4) =$  units digit of  $(4)(7)(1)(1) =$  units digit of  $28 = 8$

$x = 3$ : units digit of  $(4^7)(3^4)(7^5)(9^6) =$  units digit of  $(4)(1)(7)(1) =$  units digit of  $28 = 8$

$x = 4$ : units digit of  $(4^9)(3^5)(7^6)(9^8) =$  units digit of  $(4)(3)(9)(1) =$  units digit of  $108 = 8$

The units digit of the expression in the question must be 8.

Alternatively, note that  $x$  is a positive integer, so  $2x$  is always even, while  $2x + 1$  is always odd.

Thus,

$(4)^{(2x+1)} = (4)^{(\text{odd})}$ , which always has a units digit of 4

$(9)^{(2x)} = (9)^{(\text{even})}$ , which always has a units digit of 1

That leaves us to find the units digit of  $(3)^{(x+1)}(7)^{(x+2)}$ . Rewriting, and dropping all but the units digit at each intermediate step,

$$(3)^{(x+1)}(7)^{(x+2)}$$

$$= (3)^{(x+1)}(7)^{(x+1)}(7)$$

$$= (3 \times 7)^{(x+1)}(7)$$

$$= (21)^{(x+1)}(7)$$

$$= (1)^{(x+1)}(7) = 7, \text{ for any value of } x.$$

So, the units digit of  $(4)^{(2x+1)}(3)^{(x+1)}(7)^{(x+2)}(9)^{(2x)}$  is  $(4)(7)(1) = 28$ , then once again drop all but the units digit to get 8.

The correct answer is D.

## 5.

Units digit questions often times involve recognition of a pattern.

The units digit of  $n$  is determined solely by the units digit of the expressions  $5^x$  and  $7^{y+15}$ , because when two numbers are added together, the units digit of the sum is determined solely by the units digits of the two numbers.

Since  $x$  is a positive integer,  $5^x$  always ends in a 5 ( $5^2 = 25$ ,  $5^3 = 125$ ,  $5^4 = 625$ ). This property is also shared by the integer 6.

The units digit of a power of 7 is not consistent. The value of  $x$  becomes a non-factor here.

The question can be rephrased as "what is the units digit of  $7^{y+15}$ ?" or potentially just "what is  $y$ ?"

(1) INSUFFICIENT: This statement cannot be used to find the value of  $y$  or the units digit of  $7^{y+15}$ .

(2) SUFFICIENT: This statement can be used to solve for two potential values for  $y$ . The

quadratic can be factored:

$(y - 5)(y - 1) = 0$ , so  $y = 1$  or  $5$ . This does NOT sufficiently answer the question "what is  $y$ ?" but it DOES provide a single answer to the question "what is the units digit of  $7^{y+15}$ ?"

Powers of 7 have units digits that follow a specific pattern:

$7^0$	<b>1</b>
$7^1$	<b>7</b>
$7^2$	<b>49</b>
$7^3$	<b>343</b>
$7^4$	<b>2401</b>

The pattern is 1, 7, 9 and 3, repeating in iterations of four. The two possible values for  $y$  according to statement (2) are 1 and 5, which means that  $7^{y+15}$  is either  $7^{16}$  or  $7^{20}$ . Both  $7^{16}$  and  $7^{20}$  have a units digit of 1 (according to the pattern). Ultimately this means that  $n$  will have a units digit of  $5 + 1 = 6$ .

The correct answer is (B), statement (2) ALONE is sufficient to answer the question, but statement (1) alone is not.

## 6.

In order to answer this, we need to recognize a common GMAT pattern: the difference of two squares. In its simplest form, the difference of two squares can be factored as follows:

$x^2 - y^2 = (x + y)(x - y)$ . Where, though, is the difference of two squares in the question above? It pays to recall that all even exponents are squares. For example,

$$x^4 = (x^2)(x^2)$$

$$x^{56} = (x^{28})(x^{28})$$

Because the numerator in the expression in the question is the difference of two even exponents, we can factor it as the difference of two squares and simplify:

$$\frac{(13!)^{16} - (13!)^8}{(13!)^8 + (13!)^4} = a$$

$$\frac{\cancel{((13!)^8 + (13!)^4)} \left[ (13!)^8 - (13!)^4 \right]}{\cancel{(13!)^8 + (13!)^4}} = a$$

$$(13!)^8 - (13!)^4 = a$$

$$(13!)^4 \left[ (13!)^4 - 1 \right] = a$$

$$(13!)^4 - 1 = \frac{a}{(13!)^4}$$

The units digit of the left side of the equation is equal to the units digit of the right side of the equation (which is what the question asks about). Thus, if we can determine the units digit of the expression on the left side of the equation, we can answer the question.

Since  $(13!) = 13 \times 12 \times 11 \times 10 \dots \times 1$ , we know that  $13!$  contains a factor of 10, so its units digit

must be 0. Similarly, the units digit of  $(13!)^4$  will also have a units digit of 0. If we subtract 1 from this, we will be left with a number ending in 9.

Therefore, the units digit of  $\frac{a}{(13!)^4}$  is 9. The correct answer is E.

7.

We know from the question that  $x$  and  $y$  are integers and also that they are both greater than 0. Because we are only concerned with the units digit of  $n$  and because both bases end in 3 (243 and 463), we simply need to know  $x + y$  to figure out the units digit for  $n$ . Why? Because, to get the units digit, we are simply going to complete the operation  $3^x \times 3^y$  which, using our exponent rules, simplifies to  $3^{(x+y)}$ .

So we can rephrase the question as "What is  $x + y$ ?"

(1) SUFFICIENT: This tells us that  $x + y = 7$ . Therefore, the units digit of the expression in the question will be the same as the units digit of  $3^7$ .

(2) INSUFFICIENT: This gives us no information about  $y$ .

The correct answer is A.

8.

(1) INSUFFICIENT: This statement does not provide enough information to determine the units digit of  $x^2$ . For example,  $x^4$  could be 1 in which case  $x = 1$  and the units digit of  $x^2$  is 1, or  $x^4$  could be 81 in which case  $x = 3$  and the units digit of  $x^2$  is 9.

(2) SUFFICIENT: Given that the units digit of  $x$  is 3, we know that the units digit of  $x^2$  is 9.

The correct answer is B.

## DECIMALS

1.

To determine the value of  $10 - x$ , we must determine the exact value of  $x$ . To determine the value of  $x$ , we must find out what digits  $a$  and  $b$  represent. Thus, the question can be rephrased: What is  $a$  and what is  $b$ ?

(1) INSUFFICIENT: This tells us that  $x$  rounded to the nearest hundredth must be 1.44. This means that  $a$ , the hundredths digit, might be either 3 (if the hundredths digit was rounded up to 4) or 4 (if the hundredths digit was rounded down to 4). This statement alone is NOT sufficient since it does not give us a definitive value for  $a$  and tells us nothing about  $b$ .

(2) SUFFICIENT: This tells us that  $x$  rounded to the nearest thousandth must be 1.436. This means, that  $a$ , the hundredths digit, is equal to 3. As for  $b$ , the thousandths digit, we know that it is followed by a 5 (the ten-thousandths digit); therefore, if  $x$  is rounded to the nearest thousandth,  $b$  must rounded UP. Since  $b$  is rounded UP to 6, then we know that  $b$  must be equal to 5. Statement (2) alone is sufficient because it provides us with definitive values for both  $a$  and  $b$ .

The correct answer is B.

2.

For fraction  $p/q$  to be a terminating decimal, the numerator must be an integer and the denominator must be an integer that can be expressed in the form of  $2^x5^y$  where  $x$  and  $y$  are nonnegative integers. (Any integer divided by a power of 2 or 5 will result in a terminating decimal.)

The numerator  $p, 2^a3^b$ , is definitely an integer since  $a$  and  $b$  are defined as integers in the question.

The denominator  $q, 2^c3^d5^e$ , could be rewritten in the form of  $2^x5^y$  if we could somehow eliminate the expression  $3^d$ . This could happen if the power of 3 in the numerator ( $b$ ) is greater than the power of 3 in the denominator ( $d$ ), thereby canceling out the expression  $3^d$ . Thus, we could rephrase this question as, is  $b > d$ ?

(1) INSUFFICIENT. This does not answer the rephrased question "is  $b > d$ ?" The denominator  $q$  is not in the form of  $2^x5^y$  so we cannot determine whether or not  $p/q$  will be a terminating decimal.

(2) SUFFICIENT. This answers the question "is  $b > d$ ?"

The correct answer is B.

3.

(1) SUFFICIENT: If the denominator of  $d$  is exactly 8 times the numerator, then  $d$  can be simplified to  $1/8$ . Rewritten as a decimal, this is 0.125. Thus, there are not more than 3 nonzero digits to the right of the decimal.

(2) INSUFFICIENT: Knowing that  $d$  is equal to a non-repeating decimal does not provide any information about how many nonzero digits are to the right of the decimal point in the decimal representation of  $d$ .

The correct answer is A.

4.

The question asks us to determine whether the number  $(5/28)(3.02)(90\%)(x)$  can be represented in a finite number of non-zero decimal digits. A number can be represented in a finite number of non-zero decimal digits when the denominator of its reduced fraction contains only integer powers of 2 and 5 (in other words, 2 raised to an integer and 5 raised to an integer). For example,  $3/20$  CAN be represented by a finite number of decimal digits, since the denominator equals 4 times 5 which are both integer powers of 2 and 5 (that is, 2 to the 2nd power and 5 to the 1st power).

We can manipulate the original expression as follows:

$$\begin{aligned} (5/28) (3.02) (90\%) x \\ (5/28) (302/100) (90/100) x \end{aligned}$$

The 100's in the denominator consist of powers of 2 and 5, so the only problematic number in the denominator is the 28 -- specifically, the factor of 7 in the 28. So any value of  $x$  that removes

the 7 from the denominator will allow the entire fraction to be represented in a finite number of non-zero decimal digits.

We have to make sure that this 7 doesn't cancel with anything already present in the combined numerator, but none of the numbers in the numerator (that is, 5, 302, and 90) contain a factor of 7.

(1) INSUFFICIENT: Statement (1) says that  $x$  is greater than 100. If  $x$  has a factor of 7, say 112, then the expression can be reduced to a finite number of non-zero decimal digits. Otherwise the number will be represented with an infinite number of (repeating) decimal digits.

(2) SUFFICIENT: Statement (2) tells us that  $x$  is divisible by 21. Multiplying the expression by any multiple of 21 will remove the factor of 7 from the denominator, so the resultant number can be represented by a finite number of digits. For example, when  $x = 21$ , the expression can be manipulated as follows:

$$\begin{aligned} & (5/28) (302/100) (90/100) (21) \\ &= (5/28) (21) (302/100) (90/100) \\ & 5 (3/4) (302/100) (90/100) \end{aligned}$$

All the factors in the combined denominator are powers of 2 and 5, so it can be represented in a finite number of digits.

The correct answer is B.

## 5.

From statement (1), we know that  $d - e$  must equal a positive perfect square. This means that  $d$  is greater than  $e$ . In addition, since any single digit minus any other single digit can yield a maximum of 9,  $d - e$  could only result in the perfect squares 9, 4, or 1.

However, this leaves numerous possibilities for the values of  $d$  and  $e$  respectively. For example, two possibilities are as follows:

$$d = 7, e = 3 (d - e = \text{the perfect square } 4)$$

$$d = 3, e = 2 (d - e = \text{the perfect square } 1)$$

In the first case, the decimal  $.4de$  would be  $.473$ , which, when rounded to the nearest tenth, is equal to  $.5$ . In the second case, the decimal would be  $.432$ , which, when rounded to the nearest tenth, is  $.4$ . Thus, statement (1) is not sufficient on its own to answer the question.

Statement (2) tells us that  $\sqrt{d} > e^2$ . Since  $d$  is a single digit, the maximum value for  $d$  is 9, which means the maximum square root of  $d$  is 3. This means that  $e^2$  must be less than 3. Thus the digit  $e$  can only be 0 or 1.

However, this leaves numerous possibilities for the values of  $d$  and  $e$  respectively. For example, two possibilities are as follows:

$$d = 9, e = 1$$

$$d = 2, e = 0$$

In the first case, the decimal  $.4de$  would be  $.491$ , which, when rounded to the nearest tenth, is equal to  $.5$ . In the second case, the decimal would be  $.420$ , which, when rounded to the nearest tenth, is  $.4$ . Thus, statement (2) is not sufficient on its own to answer the question.

Taking both statements together, we know that  $e$  must be 0 or 1 and that  $d - e$  is equal to 9, 4 or 1.

This leaves the following 4 possibilities:

$$d = 9, e = 0$$

$$d = 5, e = 1$$

$$d = 4, e = 0$$

$$d = 1, e = 0$$

These possibilities yield the following four decimals: .490, .451, .440, and .410 respectively. The first two of these decimals yield .5 when rounded to the nearest tenth, while the second two decimals yield .4 when rounded to the nearest tenth.

Thus, both statements taken together are not sufficient to answer the question.

The correct answer is E: Statements (1) and (2) TOGETHER are NOT sufficient.

**6.**

Obviously is D

7.

The question asks whether  $8.3x\gamma$  equals 8.3 when it's rounded to the nearest tenth. This is a Yes/No question, so all we need is a definite "Yes" or a definite "No" for the statement to be sufficient.

(1) SUFFICIENT: When  $x = 5$ , then  $8.35\gamma$  rounded to the nearest tenth equals 8.4. Therefore, we have answered the question with a definite "No," so statement (1) is sufficient.

(2) INSUFFICIENT: When  $\gamma = 9$ , then  $8.3x9$  can round to either 8.3 or to 8.4 depending on the value of  $x$ . For example, if  $x = 0$ , then 8.309 rounds to 8.3. If  $x = 9$ , then 8.99 rounds to 8.4. Therefore statement (2) is insufficient.

The correct answer is A.

8.

To determine the value of  $y$  rounded to the nearest tenth, we only need to know the value of  $j$ . This is due to the fact that 3 is the hundredths digit (the digit that immediately follows  $j$ ), which means that  $j$  will not be rounded up. Thus,  $y$  rounded to the nearest tenth is simply  $2.j$ . We are looking for a statement that leads us to the value of  $j$ .

(1) INSUFFICIENT: This does not provide information that allows us to determine the value of  $j$ .

(2) SUFFICIENT: Since rounding  $y$  to the nearest hundredth has no effect on the tenths digit  $j$ , this statement is essentially telling us that  $j = 7$ . Thus,  $y$  rounded to the nearest tenth equals 2.7. This statement alone answers the question.

The correct answer is B.

## Sequences and Series

1. For sequence  $S$ , any value  $S_n$  equals  $6n$ . Therefore, the problem can be restated as determining the sum of all multiples of 6 between 78 ( $S_{13}$ ) and 168 ( $S_{28}$ ), inclusive. The direct but time-consuming approach would be to manually add the terms:  $78 + 84 = 162$ ;  $162 + 90 = 252$ ; and so forth.

The solution can be found more efficiently by identifying the median of the set and multiplying by the number of terms. Because this set includes an even number of terms, the median equals the average of the two 'middle' terms,  $S_{20}$  and  $S_{21}$ , or  $(120 + 126)/2 = 123$ . Given that there are 16 terms in the set, the answer is  $16(123) = 1,968$ .

The correct answer is D.

2. Sequence  $A$  defines the infinite set:  $10, 13, 16 \dots 3n + 7$ .  
Set  $B$  is a finite set that contains the first  $x$  members of sequence  $A$ .

Set  $B$  is based on an evenly spaced sequence, so its members are also evenly spaced. All evenly spaced sets share the following property: the mean of an evenly spaced set is equal to the median. The most common application of this is in consecutive sets, a type of evenly spaced set. Since the median and mean are the same, we can rephrase this question as: "What is either the median or the mean of set  $B$ ?"

(1) SUFFICIENT: Only one set of numbers with the pattern  $10, 13, 16 \dots$  will add to 275, which means only one value for  $n$  (the number of terms) will produce a sum of 275. For example,

If  $n = 2$ , then  $10 + 13 = 23$

If  $n = 3$ , then  $10 + 13 + 16 = 39$

We can continue these calculations until we reach a sum of 275, at which point we know the value of  $n$ . If we know the value for  $n$ , then we can write out all of the terms, allowing us to find the median (or the mean). In this case, when  $n = 11$ ,  $10 + 13 + 16 + 19 + 22 + 25 + 28 + 31 + 34 + 37 + 40 = 275$ . The median is 25. (Though we don't have to do these calculations to see that this statement is sufficient.)

Alternatively, the sum of a set = (the number of terms in the set)  $\times$  (the mean of the set). The number of the terms of set  $B$  is  $n$ . The first term is 10 and the last (or  $n$ th) term in the set will have a value of  $3n + 7$ , so the mean of the set =  $(10 + 3n + 7)/2$ .

Therefore, we can set up the following equation:  $275 = n(10 + 3n + 7)/2$

Simplifying, we get the quadratic:  $3n^2 + 17n - 550 = 0$ .

This quadratic factors to  $(3n + 50)(n - 11) = 0$ , which only has one positive integer root, 11.

Note that we can see that this is sufficient without actually solving this quadratic, however. The -550 implies that if there are two solutions (not all quadratics have two solutions) there must be a positive and a negative solution. Only the positive solution makes sense for the number of terms in a set, so we know we will have only one positive solution.

Once we have the number of terms in the set, we can use this to calculate the mean (though, again, because this is data sufficiency, we can stop our calculations prior to this point):

$$= (10 + 3n + 7)/2 = (10 + 3(11) + 7)/2 = 50/2 = 25.$$

(2) SUFFICIENT: The first term of set  $B$  is 10. If the range is 30, the last term must be  $10 + 30 = 40$ . The mean of the set then must be  $(10 + 40)/2 = 25$ . This is sufficient.

The correct answer is D.

3.

We can use the formula to calculate the first 10 values of  $S$ :

$$S_1 = 3$$

$$S_2 = 2(3) - 2 = 4$$

$$S_3 = 2(4) - 2 = 6$$

$$S_4 = 2(6) - 2 = 10$$

$$S_5 = 2(10) - 2 = 18$$

$$S_6 = 2(18) - 2 = 34$$

$$S_7 = 2(34) - 2 = 66$$

$$S_8 = 2(66) - 2 = 130$$

$$S_9 = 2(130) - 2 = 258$$

$$S_{10} = 2(258) - 2 = 514$$

$$S_{10} - S_9 = 514 - 258 = 256.$$

Alternatively, we could solve this problem by noticing the following pattern in the sequence:

$$\begin{aligned} S_2 - S_1 &= 1 \text{ or } (2^0) \\ S_3 - S_2 &= 2 \text{ or } (2^1) \\ S_4 - S_3 &= 4 \text{ or } (2^2) \\ S_5 - S_4 &= 8 \text{ or } (2^3) \end{aligned}$$

We could extrapolate this pattern to see that  $S_{10} - S_9 = 2^8 = 256$ .  
The correct answer is E

**4.**

To find each successive term in  $S$ , we add 1 to the previous term and add this to the reciprocal of the previous term plus 1.

$$S_1 = 201$$

$$S_2 = (201 + 1) + \frac{1}{(201 + 1)} = 202 + \frac{1}{202}$$

$$S_3 = \left( 202 + \frac{1}{202} + 1 \right) + \frac{1}{\left( 202 + \frac{1}{202} + 1 \right)} = 203 + \frac{1}{202} + \frac{1}{203 + \frac{1}{202}}$$

The question asks to estimate  $(Q)$ , the sum of the first 50 terms of  $S$ . If we look at the endpoints of the intervals in the answer choices, we see we have quite a bit of leeway as far as our estimation is concerned. In fact, we can simply ignore the fractional portion of each term. Let's use  $S_2 \approx 202$ ,  $S_3 \approx 203$ . In this way, the sum of the first 50 terms of  $S$  will be approximately equal to the sum of the fifty consecutive integers 201, 202 ... 250.

To find the sum of the 50 consecutive integers, we can multiply the mean of the integers by the number of integers since average = sum / (number of terms).

$$\text{The mean of these 50 integers} = (201 + 250) / 2 = 225.5$$

Therefore, the sum of these 50 integers =  $50 \times 225.5 = 11,275$ , which falls between 11,000 and 12,000. The correct answer is C.

**5.**

At the end of the first week, there are 5 members. During the second week,  $5x$  new members are brought in ( $x$  new members for every existing member). During the third week, the previous week's new members ( $5x$ ) each bring in  $x$  new members:  $(5x)x = 5x^2$  new members. If we continue this pattern to the twelfth week, we will see that  $5x^{11}$  new members join the club that week. Since  $y$  is the number of new members joining during week 12,  $y = 5x^{11}$ .

If  $y = 5x^{11}$ , we can set each of the answer choices equal to  $5x^{11}$  and see which one yields an integer value (since  $y$  is a specific number of people, it must be an integer value). The only choice to yield an integer value is (D):

$$5x^{11} = 3^{11}5^{12}$$

$$\frac{5x^{11}}{5} = \frac{3^{11}5^{12}}{5}$$

$$x^{11} = 3^{11}5^{11}$$

$$\sqrt[11]{x^{11}} = \sqrt[11]{3^{11}5^{11}}$$

$$x = (3)(5)$$

Therefore  $x = 15$ .

Since choice (D) is the only one to yield an integer value, it is the correct answer.

**6.**

Since the membership of the new group increases by 700% every 10 months, after the first 10-month period the new group will have  $(8)(4)$  members (remember that to increase by 700% is to increase eightfold). After the second 10-month period, it will have  $(8)(8)(4)$  members. After the third 10-month period, it will have  $(8)(8)(8)(4)$  members. We can now see a pattern: the number of members in the new group can be expressed as  $(4)(8^x)$ , where  $x$  is the number of 10-month periods that have elapsed.

Since the membership of the established group doubles every 5 months (remember, to increase by 100% is to double), it will have  $(2)(4096)$  after the first 5-month period. After another 5 months, it will have  $(2)((2)(4096))$  members. After another 5 months, it will have  $(2)((2)(2)(4096))$ . We can now see a pattern: the number of members in the established group will be equal to  $(4096)(2^y)$ , where  $y$  represents the number of 5-month periods that have elapsed.

The question asks us after how many months the two groups will have the same number of members.

Essentially, then, we need to know when  $(4096)(2^y) = (4)(8^x)$ . Since  $y$  represents the number of 5-month periods and  $x$  represents the number of 10-month periods, we know that  $y = 2x$ . We can rewrite the equation as  $(4096)(2^{2x}) = (4)(8^x)$ . We now need to solve for  $x$ , which represents the number of 10-month periods that elapse before the two groups have the same number of members.

The next step we need to take is to break all numbers down into their prime factors:

$$4 = 2^2$$

$$8 = 2^3$$

$$4096 = 2^{12}$$

We can now rewrite the equation:

$$(2^{12})(2^{2x}) = (2^2)(2^3)^x \rightarrow$$

$$2^{2x+12} = (2^2)(2^{3x}) \rightarrow$$

$$2^{2x+12} = 2^{3x+2}$$

Since the bases are equal on both sides of the equation, the exponents must be equal as well. Therefore, it must be true that  $2x + 12 = 3x + 2$ . We can solve for  $x$ :

$$2x + 12 = 3x + 2 \rightarrow$$

$$10 = x$$

If  $x = 10$ , then 10 ten-month periods will elapse before the two groups have equal membership rolls, for a total of 100 months.

The correct answer is E.

**7.**

We are given  $x = \sqrt{2 + \sqrt{2 + \sqrt{2 + \sqrt{2 + \sqrt{2 + \dots}}}}}$ .

$$x = \sqrt{2 + \left( \sqrt{2 + \sqrt{2 + \sqrt{2 + \dots}}} \right)}$$

This can be rewritten as:

Since the entire right-hand-side of the equation repeats itself an infinite number of times, we can say that the expression inside the parentheses is actually equal to  $x$ .

Consequently, we can replace the expression within the parentheses by  $x$  as follows:

$$x = \sqrt{2 + x}$$

Now we have an equation for which we can solve for  $x$  as follows:

$$x = \sqrt{2 + x}$$

$$x^2 = 2 + x$$

$$x^2 - x - 2 = 0$$

$$(x - 2)(x + 1) = 0$$

$$x = \{2, -1\}$$

Since  $x$  was specified to be a positive number,  $x = 2$ . The correct answer is B.

### Remainders, Divisibility

1.

If there is a remainder of 5 when  $x$  is divided by 9, it must be true that  $x$  is five more than a multiple of 9. We can express this algebraically as  $x = 9a + 5$ , where  $a$  is a positive integer.

The question asks for the remainder when  $3x$  is divided by 9. If  $x = 9a + 5$ , then  $3x$  can be expressed as  $3x = 27a + 15$  (we just multiply the equation by 3). If we divide the right side of the equation by 9, we get  $3a + 15/9$ . 9 will go once into 15, leaving a remainder of 6.

Alternatively, we can pick numbers. If we add the divisor (in this case 9) to the remainder (in this case 5) we get the smallest possibility for  $x$ .  $9 + 5 = 14$  (and note that  $14/9$  leaves a remainder of 5).  $3x$  then gives us  $3(14) = 42$ .  $42/9$  gives us 4 remainder 6 (since  $4 \times 9 = 36$  and  $36 + 6 = 42$ ).

The correct answer is E.

2.

The value  $\sqrt{288kx}$  can be simplified to  $12\sqrt{2kx}$ . Given that  $x$  is divisible by 6, for the purpose of solving this problem  $x$  might be restated as  $6y$ , where  $y$  may be any positive integer. The expression  $\sqrt{288kx}$  could then be further simplified to

$$12\sqrt{12ky} \text{ or}$$

$$24\sqrt{3ky}$$

Therefore each answer choice CAN be a solution if and only if there is an integer  $y$  such that  $24\sqrt{3ky}$  equals that answer choice. The following table shows such an integer value of  $y$  for four of the possible answer choices, which therefore CAN be a solution.

$y$	Solution
-----	----------

1	$24\sqrt{3k}$
2	$24\sqrt{6k}$
3	$72\sqrt{k}$
$k$	$24k\sqrt{3}$

The answer choice that cannot be the value of  $\sqrt{288kx}$  is  $24\sqrt{k}$ . For this expression to be a possible solution,  $y$  would have to equal  $1/3$ , which is not a positive integer. Put another way, this solution would require that  $x = 2$ , which cannot be true because  $x$  is divisible by 6.

The correct answer is B.

3.

First consider an easier expression such as  $10^5 - 560$ . Doing the computation yields 99,440, which has 2 9's followed by 440.

From this, we can extrapolate that  $10^{25} - 560$  will have a string of 22 9's followed by 440.

Now simply apply your divisibility rules:

You might want to skip 11 first because there is no straightforward rule for divisibility by 11. You can always return to this if necessary. [One complex way to test divisibility by 11 is to assign opposite signs to adjacent digits and then to add them to see if they add up to 0. For example, we know that 121 is divisible by 11 because  $-1 + 2 - 1$  equals zero. In our case, the twenty-two 9s, when assigned opposite signs, will add up to zero, and so will the digits of 440, since  $+4 - 4 + 0$  equals zero.]

If the last three digits of the number are divisible by 8, the number is divisible by 8. Since 440 is divisible by 8, the entire expression is divisible by 8.

If the last two digits of the number are divisible by 4, the number is divisible by 4. Since 40 is divisible by 4, the entire expression is divisible by 4.

If a number ends in 0 or 5, it is divisible by 5. Since the expression ends in 0, it is divisible by 5. For a number to be divisible by three, the sum of the digits must be divisible by three. The sum of the 22 9's will be divisible by three but when you add the sum of the last three digits, 8 ( $4 + 4 + 0$ ), the result will not be divisible by 3. Thus, the expression will NOT be divisible by 3.

The correct answer is E.

4.

The remainder is what is left over after 4 has gone wholly into  $x$  as many times as possible. For example, suppose that  $x$  is 10. 4 goes into 10 two whole times ( $2 \times 4 = 8 < 10$ ), but not quite three times ( $3 \times 4 = 12 > 10$ ). The remainder is what is left over:  $10 - 8 = 2$ .

(1) INSUFFICIENT: This statement tells us that  $x/3$  must be an odd integer, because that is the only way we would have a remainder of 1 after dividing by 2. Thus,  $x$  is  $(3 \times \text{an odd integer})$ , and  $(\text{odd} \times \text{odd} = \text{odd})$ , so  $x$  must be an odd multiple of 3. The question stem tells us that  $x$  is positive. So,  $x$  could be any positive, odd integer that is a multiple of 3: 3, 9, 15, 21, 27, 33, 39, 45, etc. Now we need to answer the question "when  $x$  is divided by 4, is the remainder equal to 3?" for every possible value of  $x$  on the list. For  $x = 15$ , the answer is "yes," since  $15/4$  results in a remainder of 3. For  $x = 9$ , the answer is "no," since  $9/4$  results in a remainder of 1. The answer to the question might be "yes" or "no," depending on the value of  $x$ , so we are not able to give a

definite answer based on the information given.

(2) INSUFFICIENT: This statement tells us that  $x$  is a multiple of 5. The question stem tells us that  $x$  is a positive integer. So,  $x$  could be any positive integer that is a multiple of 5: 5, 10, 15, 20, 25, 30, 35, 40, 45, etc. Now we need to answer the question "when  $x$  is divided by 4, is the remainder equal to 3?" for every possible value of  $x$  on the list. For  $x = 15$ , the answer is "yes," since  $15/4$  results in a remainder of 3. For  $x = 5$ , the answer is "no," since  $5/4$  results in a remainder of 1. The answer to the question might be "yes" or "no," depending on the value of  $x$ , so we are not able to give a definite answer based on the information given.

(1) AND (2) INSUFFICIENT: From the two statements, we know that  $x$  is an odd multiple of 3 and that  $x$  is a multiple of 5. In order for  $x$  to be both a multiple of 3 and 5, it must be a multiple of 15 ( $15 = 3 \times 5$ ). The question stem tells us that  $x$  is a positive integer. So,  $x$  could be any odd, positive integer that is a multiple of 15: 15, 45, 75, 105, etc. Now we need to answer the question "when  $x$  is divided by 4, is the remainder equal to 3?" for every possible value of  $x$  on the list. For  $x = 15$ , the answer is "yes," since  $15/4$  results in a remainder of 3. For  $x = 45$ , the answer is "no," since  $45/4$  results in a remainder of 1. The answer to the question might be "yes" or "no," depending on the value of  $x$ , so we are not able to give a definite answer based on the information given.

The correct answer is E.

5.

A remainder, by definition, is always smaller than the divisor and always an integer. In this problem, the divisor is 7, so the remainders all must be integers smaller than 7. The possibilities, then, are 0, 1, 2, 3, 4, 5, and 6. In order to calculate the sum, we need to know which remainders are created.

(1) INSUFFICIENT: The range is defined as the difference between the largest number and the smallest number in a given set of integers. In this particular question, a range of 6 indicates that the difference between the largest remainder and the smallest remainder is 6. However, this does not tell us any information about the rest of the remainders; though we know the smallest term is 0, and the largest is 6, the other remainders could be any values between 0 and 6, which would result in varying sums.

(2) SUFFICIENT: By definition, when we divide a consecutive set of seven integers by seven, we will get one each of the seven possibilities for remainder. For example, let's pick 11, 12, 13, 14, 15, 16, and 17 for our set of seven integers ( $x_1$  through  $x_7$ ). The remainders are as follows:

$$x_1 = 11. \quad 11/7 = 1 \text{ remainder } 4$$

$$x_2 = 12. \quad 12/7 = 1 \text{ remainder } 5$$

$$x_3 = 13. \quad 13/7 = 1 \text{ remainder } 6$$

$$x_4 = 14. \quad 14/7 = 2 \text{ remainder } 0$$

$$x_5 = 15. \quad 15/7 = 2 \text{ remainder } 1$$

$$x_6 = 16. \quad 16/7 = 2 \text{ remainder } 2$$

$$x_7 = 17. \quad 17/7 = 2 \text{ remainder } 3$$

Alternatively, you can solve the problem algebraically. When you pick 7 consecutive integers on a number line, one and only one of the integers will be a multiple of 7. This number can be expressed as  $7n$ , where  $n$  is an integer. Each of the other six consecutive integers will cover one of the other possible remainders: 1, 2, 3, 4, 5, and 6. It makes no difference whether the multiple of 7 is the first integer in the set, the middle one or the last. To prove this consider the set in which the multiple of 7 is the first integer in the set. The seven consecutive integers will

be:  $7n, 7n + 1, 7n + 2, 7n + 3, 7n + 4, 7n + 5, 7n + 6$ . The sum of the remainders here would be  $0 + 1 + 2 + 3 + 4 + 5 + 6 = 21$ .

The correct answer is B.

## 6.

(1) INSUFFICIENT: At first glance, this may seem sufficient since if 5 is the remainder when  $k$  is divided by  $j$ , then there will *always* exist a positive integer  $m$  such that  $k = jm + 5$ . In this case,  $m$  is equal to the integer quotient and 5 is the remainder. For example, if  $k = 13$  and  $j = 8$ , and 13 divided by 8 has remainder 5, it *must* follow that there exists an  $m$  such that  $k = jm + 5$ :  $m = 1$  and  $13 = (8)(1) + 5$ .

However, the logic does not go the other way: 5 is not necessarily the remainder when  $k$  is divided by  $j$ . For example, if  $k = 13$  and  $j = 2$ , there exists an  $m$  ( $m = 4$ ) such that  $k = jm + 5$ :  $13 = (2)(4) + 5$ , consistent with statement (1), yet 13 divided by 2 has remainder 1 rather than 5.

When  $j < 5$  (e.g.,  $2 < 5$ ); this means that  $j$  can go into 5 (e.g., 2 can go into 5) at least one more time, and consequently  $m$  is not the true quotient of  $k$  divided by  $j$  and 5 is not the true remainder. Similarly, if we let  $k = 14$  and  $j = 3$ , there exists an  $m$  (e.g.,  $m = 3$ ) such that statement (1) is also satisfied [i.e.,  $14 = (3)(3) + 5$ ], yet the remainder when 14 is divided by 3 is 2, a different result than the first example.

Statement (1) tells us that  $k = jm + 5$ , where  $m$  is a positive integer. That means that  $k/j = m + 5/j = \text{integer} + 5/j$ . Thus, the remainder when  $k$  is divided by  $j$  is either 5 (when  $j > 5$ ), or equal to the remainder of  $5/j$  (when  $j$  is 5 or less). Since we do not know whether  $j$  is greater than or less than 5, we cannot determine the remainder when  $k$  is divided by  $j$ .

(2) INSUFFICIENT: This only gives the range of possible values of  $j$  and by itself does not give any insight as to the value of the remainder when  $k$  is divided by  $j$ .

(1) AND (2) SUFFICIENT: Statement (1) was not sufficient because we were not given whether  $5 > j$ , so we could not be sure whether  $j$  could go into 5 (or  $k$ ) any additional times. However, (2) tells us that  $j > 5$ , so we now know that  $j$  cannot go into 5 any more times. This means that  $m$  is the exact number of times that  $k$  can be divided by  $j$  and that 5 is the true remainder.

Another way of putting this is: From statement (1) we know that  $k/j = m + 5/j = \text{integer} + 5/j$ . From statement (2) we know that  $j > 5$ . Therefore, the remainder when  $k$  is divided by  $j$  must always be 5.

The correct answer is C.

## 7.

In a set of consecutive integers with an odd number of terms, the average of the set is the middle term. Since the question tells us that we have 5 consecutive integers, we know that the average of the set is the middle term. For example, in the set  $\{1, 2, 3, 4, 5\}$ , the average is  $15/5 = 3$ , which is the middle term. We are also told that the average is odd, which means the 5 integers of the set must go as follows:  $\{\text{odd, even, odd, even, odd}\}$ .

We are then asked for the remainder when the largest of the five integers is divided by 4. Since the largest integer must be odd, we know that it cannot be a multiple of 4 itself. So the remainder depends on how far this largest integer is from the closest multiple of 4 smaller than it. Since there are five numbers in the set, at least one of them must be a multiple of 4

(remember that counting from 1, every fourth integer is a multiple of 4).

Statement 1 tells us that the third of the five integers is a prime number. The third integer is the middle integer. Knowing that it is a prime number does not tell us which of the five integers is a multiple of 4. If the middle number is 17, then the second number is 16 (a multiple of 4) and the largest number is 19, yielding a remainder of 3 when divided by 4. But if the middle number is 7, then the fourth number is 8 (a multiple of 4) and the largest number is 9, yielding a remainder of 1 when divided by 4. Insufficient.

Statement 2 tells us that the second of the integers is the square of an integer. Since the middle integer is odd, we know the second integer is even. If the second integer is even **and** the square of an integer, it must be a multiple of 4.

To see this clearly, let's think about the square root of the second integer. Since the second integer is even, its square root must be even. We can call this root  $2x$  (since all even numbers are multiples of 2). Now, to find the second integer, we must square  $2x$  to get  $4x^2$ . So the second integer must be a multiple of 4. Therefore, the largest integer can be expressed as  $4x^2 + 3$ . So the remainder when the largest integer is divided by 4 will be 3. Sufficient.

The correct answer is B: Statement 2 alone is sufficient to answer the question but statement 1 alone is not.

8.

For the cookies to be split evenly between Laurel and Jean without leftovers, the number of cookies,  $c$ , must be even. We can rephrase the question: "Is  $c$  even?"

(1) INSUFFICIENT: If there is one cookie left over when  $c$  is divided among three people, then  $c = 3x + 1$ , where  $x$  is an integer. This does not tell us if  $c$  is odd or even. The expression  $3x$  could be odd or even (depending on  $x$ ) so adding 1 to it could result in an odd or even answer. For example, if  $x = 1$ , then  $c = 4$ , which is even. If  $x = 2$ , then  $c = 7$ , which is odd.

(2) SUFFICIENT: If the cookies will divide evenly by two if three cookies are first eaten, then  $c - 3$  is even.  $c$  itself must be odd: an odd minus an odd is even. This answers our rephrased question with a definite NO. (Recall that "no" is a sufficient answer to a yes/no data sufficiency question. Only "maybe" is insufficient.)

The correct answer is B.

9.

(1) INSUFFICIENT: We are told that  $5n/18$  is an integer. This does not allow us to determine whether  $n/18$  is an integer. We can come up with one example where  $5n/18$  is an integer and where  $n/18$  is **NOT** an integer. We can come up with another example where  $5n/18$  is an integer and where  $n/18$  **IS** an integer.

Let's first look at an example where  $5n/18$  is equal to the integer 1.

If  $\frac{5n}{18} = 1$ , then  $\frac{n}{18} = \frac{1}{5}$ . In this case  $n/18$  is NOT an integer.

Let's next look at an example where  $5n/18$  is equal to the integer 15.

If  $\frac{5n}{18} = 15$ , then  $\frac{n}{18} = 3$ . In this case  $n/18$  IS an integer.

Thus, Statement (1) is

NOT sufficient.

(2) INSUFFICIENT: We can use the same reasoning for Statement (2) that we did for statement (1). If  $3n/18$  is equal to the integer 1, then  $n/18$  is NOT an integer. If  $3n/18$  is equal to the integer 9, then  $n/18$  IS an integer.

(1) AND (2) SUFFICIENT: If  $5n/18$  and  $3n/18$  are both integers,  $n/18$  must itself be an integer. Let's test some examples to see why this is the case.

The first possible value of  $n$  is 18, since this is the first value of  $n$  that ensures that **both**  $5n/18$  and  $3n/18$  are integers. If  $n = 18$ , then  $n/18$  is an integer. Another possible value of  $n$  is 36. (This value also ensures that both  $5n/18$  and  $3n/18$  are integers). If  $n = 36$ , then  $n/18$  is an integer.

A pattern begins to emerge: the fact that  $5n/18$  AND  $3n/18$  are both integers limits the possible values of  $n$  to multiples of 18. Since  $n$  must be a multiple of 18, we know that  $n/18$  must be an integer. The correct answer is C.

Another way to understand this solution is to note that according to (1),  $n = (18/5)*\text{integer}$ , and according to (2),  $n = 6*\text{integer}$ . In other words,  $n$  is a multiple of both  $18/5$  and 6. The least common multiple of these two numbers is 18. In order to see this, write  $6 = 30/5$ . The LCM of the numerators 18 and 30 is 90. Therefore, the LCM of the fractions is  $90/5 = 18$ .

Again, the correct answer is C.

10. The key to this problem is to recognize that in order for any integer to be divisible by 5, it must end in 0 or 5. Since we are adding a string of powers of 9, the question becomes "Does the sum of these powers of 9 end in 0 or 5?" If we knew the units digits of each power of nine, we'd be able to figure out the units digit of their sum.

9 raised to an even exponent will result in a number whose units digit is 1 (e.g.,  $9^2 = 81$ ,  $9^4 = 6561$ , etc.). If 9 raised to an even exponent always gives 1 as the units digit, then 9 raised to an odd exponent will therefore result in a number whose units digit is 9 (think about this:  $9^2 = 81$ , so  $9^3$  will be  $81 \times 9$  and the units digit will be  $1 \times 9$ ).

Since our exponents in this case are  $x, x+1, x+2, x+3, x+4$ , and  $x+5$ , we need to know whether  $x$  is an integer in order to be sure the pattern holds. (NEVER assume that an unknown is an integer unless expressly informed). If  $x$  is in fact an integer, we will have 6 consecutive integers, of which 3 will necessarily be even and 3 odd. The 3 even exponents will result in 1's and the 3 odd exponents will result in 9's. Since the three 1's can be paired with the three 9's (for a sum of 30), the units digit of  $y$  will be 0 and  $y$  will thus be divisible by 5. But we don't know whether  $x$  is an integer. For that, we need to check the statements.

Statement (1) tells us that 5 is a factor of  $x$ , which means that  $x$  must be an integer. Sufficient.

Statement (2) tells us that  $x$  is an integer. Sufficient.

The correct answer is D: EACH statement ALONE is sufficient to answer the question.

11.

When  $n$  is divided by 4 it has a remainder of 1, so  $n = 4x + 1$ , where  $x$  is an integer. Likewise when  $n$  is divided by 5 it has a remainder of 3, so  $n = 5y + 3$ , where  $y$  is an integer. To find the

two smallest values for  $n$ , we can list possible values for  $n$  based on integer values for  $x$  and  $y$ . To be a possible value for  $n$ , the value must show up on both lists:

$n = 4x + 1$	$n = 5y + 3$
5	8
9	<b>13</b>
<b>13</b>	18
17	23
21	28
25	<b>33</b>
29	38
<b>33</b>	43

The first two values for  $n$  that work with both the  $x$  and  $y$  expressions are 13 and 33. Their sum is 46.

The correct answer is B.

### 12.

The prime factors of  $n^4$  are really four sets of the prime factors of the integer  $n$ .

Since  $n^4$  is divisible by 32 (or  $2^5$ ),  $n^4$  must be divisible by 2 at least 5 times. What does this tell us about the integer  $n$ ?

If  $n$  is divisible by only one 2, then  $n^4$  would be divisible by exactly four 2's (since the prime factors of  $n^4$  have no source other than the integer  $n$ ).

But we know that  $n^4$  is divisible by at least *five* 2's! This means that  $n$  must be divisible by at least two 2's (which means that  $n^4$  must be divisible by eight 2's). Thus, we know that the integer  $n$  must be divisible by 4.

Now that we know that  $n$  is divisible by 4, we can consider what happens when we divide  $n$  by 32.

If we divide  $n$  by 32 we can represent this mathematically as follows:

$$n = 32b + c \quad (\text{where } b \text{ is the number of times } 32 \text{ goes into } n \text{ and } c \text{ is the integer remainder})$$

We know that  $n$  is divisible by 4 so we can rewrite this as:

$$4x = 32b + c \quad (\text{where } x \text{ is an integer})$$

This equation can be simplified, by dividing both sides by 4 as follows:

$$x = 8b + c/4$$

Since we know that  $x$  is an integer, the sum of  $8b$  and  $c/4$  must yield an integer. We know that  $8b$  is an integer so  $c/4$  must be also be an integer. Therefore,  $c$ , the remainder, must be divisible by 4.

Only answer choice B qualifies. The remainder when  $n$  is divided by 32 *could be* 4. It could not be any of the another answer choices. The correct answer is B.

### 13.

The statement "when  $x_1$  is divided by 3, the remainder is 1" can be translated mathematically as follows: There exists an integer  $n$  such that  $x_1 = 3n + 1$ .

Similarly, the statement "when  $x_2$  is divided by 12, the remainder is 4" can be translated mathematically as follows: There exists an integer  $m$  such that  $x_2 = 12m + 4$ .

$$\begin{aligned}y &= 2x_1 + x_2 \\ &= 2(3n + 1) + (12m + 4) \\ &= 6n + 2 + 12m + 4 \\ &= 6(n + 2m + 1)\end{aligned}$$

Therefore:

The expression  $(n + 2m + 1)$  must be an integer (since  $n$  and  $m$  are both integers). Therefore,  $y$  is equal to some integer multiplied by 6. This means that  $y$  is divisible by 6. Any number that is divisible by 6 must also be divisible by both 2 and 3. Hence,  $y$  must be both even and divisible by 3. Consequently, I and III must be true and the correct answer is D.

#### 14.

This question can be rephrased: Is  $r - s$  divisible by 3? Or, are  $r$  and  $s$  each divisible by 3? Statement (1) tells us that  $r$  is divisible by 735. If  $r$  is divisible by 735, it is also divisible by all the factors of 735. 3 is a factor of 735. (To test whether 3 is a factor of a number, sum its digits; if the sum is divisible by 3, then 3 is a factor of the number.) However, statement (1) does not tell us anything about whether or not  $s$  is divisible by 3. Therefore it is insufficient.

Statement (2) tells us that  $r + s$  is divisible by 3. This information alone is insufficient. Consider each of the following two cases:

CASE ONE: If  $r = 9$ , and  $s = 6$ ,  $r + s = 15$  which is divisible by 3, and  $r - s = 3$ , which is also divisible by 3.

CASE TWO: If  $r = 7$  and  $s = 5$ ,  $r + s = 12$ , which is divisible by 3, but  $r - s = 2$ , which is NOT divisible by 3.

Let's try both statements together. There is a mathematical rule that states that if two integers are each divisible by the integer  $x$ , then the sum or difference of those two integers is also divisible by  $x$ .

We know from statement (1) that  $r$  is divisible by 3. We know from statement (2) that  $r + s$  is divisible by 3. Using the converse of the aforementioned rule, we can deduce that  $s$  is divisible by 3. Then, using the rule itself, we know that the difference  $r - s$  is also divisible by 3.

The correct answer is C: BOTH statements TOGETHER are sufficient, but NEITHER statement ALONE is sufficient.

#### 15.

Statement (1) tells us that  $n$  is a prime number.

If  $n = 2$ , the lowest prime number, then  $n^2 - 1 = 4 - 1 = 3$ , which is *not* divisible by 24.

If  $n = 3$ , the next prime number, then  $n^2 - 1 = 9 - 1 = 8$  which is *not* divisible by 24.

However, if  $n = 5$ , then  $n^2 - 1 = 25 - 1 = 24$ , which *is* divisible by 24.

Thus, statement (1) alone is not sufficient.

Now let us examine statement (2). By design, this number is large enough so that it would not be easy to check numbers directly. Thus, we need to go straight to number properties.

For an expression to be divisible by 24, it must be divisible by 2, 2, 2, and 3 (since this is the prime factorization of 24). In other words, the expression must be divisible by 2 at least three times and by 3 at least once.



10,000,000,000,000,000,000,000,000.

Since the exponent in every power of 10 represents the number of zeroes (e.g.,  $10^2 = 100$ , which has two zeroes;  $10^3 = 1000$ , which has three zeroes, etc.), we must be dealing with  $10^{25}$ . Thus  $n = 25$ .

The correct answer is B.

**17.**

Statement (1) gives us information about  $n^2 + n$ , which can be rewritten as the product of two consecutive integers as follows:

$$n^2 + n = n(n + 1)$$

Since the question asks us about  $n - 1$ , we can see that we are dealing with three consecutive integers:  $n - 1$ ,  $n$ , and  $n + 1$ .

By definition, the product of consecutive nonzero integers is divisible by the number of terms. Thus the product of three consecutive nonzero integers must be divisible by 3.

Since we are told in Statement (1) that the product  $n^2 + n$  is not divisible by 3, we know that neither  $n$  nor  $n + 1$  is divisible by 3. Therefore it seems that  $n - 1$  must be divisible by 3. However, this only holds if the integers in the consecutive set are nonzero integers. Since Statement (1) does not tell us this, it is not sufficient.

Statement (2) can be rewritten as follows:

$$3n + 5 \geq k + 8$$

$$3n \geq k + 3$$

$$n \geq \frac{k}{3} + 1$$

Given that  $k$  is a positive multiple of 3, we know that  $n$  must be greater than or equal to 2. This tells us that the members of the consecutive set  $n - 1$ ,  $n$ ,  $n + 1$  are nonzero integers.

By itself, this information does not give us any information about whether  $n - 1$  is divisible by 3. Thus Statement (2) alone is not sufficient.

When both statements are taken together, we know that the members of the consecutive set  $n - 1$ ,  $n$ ,  $n + 1$  are nonzero integers and that neither  $n$  nor  $n + 1$  is divisible by 3. Therefore,  $n - 1$  must be divisible by 3.

The correct answer is C: both statements together are sufficient but neither statement alone is sufficient to answer the question.

**18.**

In order for any number to be divisible by 6, it must be divisible by both 2 and 3. Thus, in order for  $y$  to be divisible by 6,  $y$  must be even (which is the same as being divisible by 2) and  $y$  must be a multiple of 3.

We can analyze each statement more effectively by breaking  $y$  into its 2 components:  $[3^{(x-1)}]$  and  $[x]$ .

Statement (1) tells us that  $x$  is a multiple of 3.

Since  $x$  is a positive integer,  $3^{(x-1)}$  is simply 3 raised to some integer power. This component of  $y$  will always be a multiple of 3.

From statement (1) we also know that the second component of  $y$ , which is simply  $x$ , is also a

multiple of 3.

Subtracting one multiple of 3 from another multiple of 3 will yield a multiple of 3. Therefore, statement (1) tells us that  $y$  must be divisible by 3. However, this does not tell us whether  $y$  is even or not. Therefore, this is not enough information to tell us whether  $y$  is divisible by 6.

Statement (2) tells us that  $x$  is a multiple of 4. This means that  $x$  must be even.

Since  $x$  is a positive integer,  $3^{(x-1)}$  is simply 3 raised to some integer power. This component of  $y$  will always be odd.

From statement (2) we also know that the second component of  $y$ , which is simply  $x$ , is even.

Subtracting an even number from an odd number yields an odd number. Therefore, statement (2) tells us that  $y$  must be odd. Since  $y$  is odd, it cannot be divisible by 2, which means  $y$  is NOT divisible by 6. This is sufficient information to answer the question.

The correct answer is B: Statement (2) alone is sufficient, but statement (1) alone is not sufficient.

19.

$m/n$  will be an integer if  $m$  is divisible by  $n$ . For  $m$  to be divisible by  $n$ , the elements of  $n$ 's prime box (i.e. the prime factors that make up  $n$ ) must also appear in  $m$ 's prime box.

(1) INSUFFICIENT: If  $2m$  is divisible by  $n$ , the elements of  $n$ 's prime box are in  $2m$ 's prime box. However, since  $2m$  contains a 2 in its prime box because of the coefficient 2,  $m$  alone may not have all of the elements of  $n$ 's prime box. For example, if  $2m = 6$  and  $n = 2$ ,  $2m$  is divisible by  $n$  but  $m$  is not.

(2) SUFFICIENT: If  $m$  is divisible by  $2n$ ,  $m$ 's prime box contains a 2 and the elements of  $n$ 's prime box. Therefore  $m$  must be divisible by  $n$ .

The correct answer is B.

If  $a$  and  $b$  are the digits of the two-digit number  $X$ , what is the remainder when  $X$  is divided by 9?

(1)  $a + b = 11$                       (2)  $X + 7$  is divisible by 9

There is no useful rephrasing that can be done for this question. However, we can keep in mind that for a number to be divisible by 9, the sum of its digits must be divisible by 9.

(1) SUFFICIENT: The sum of the digits  $a$  and  $b$  here is not divisible by 9, so  $X$  is not divisible by 9. It turns out, however, that the sum of the digits here can also be used to find the remainder. Since the sum of the digits here has a remainder of 2 when divided by 9, the number itself has a remainder of 2 when divided by 9.

We can use a few values for  $a$  and  $b$  to show that this is the case:

When  $a = 5$  and  $b = 6$ , 56 divided by 9 has a remainder of  $56 - 54 = 2$

When  $a = 7$  and  $b = 4$ , 74 divided by 9 has a remainder of  $74 - 72 = 2$

(2) SUFFICIENT: If  $X + 7$  is divisible by 9,  $X - 2$  would also be divisible by 9 ( $X - 2 + 9 = X + 7$ ). If  $X - 2$  is divisible by 9, then  $X$  itself has a remainder of 2 when divided by 9.

Again we could use numbers to prove this:

If  $X + 7 = 27$ , then  $X = 20$ , which has a remainder of 2 when divided by 9

If  $X + 7 = 18$ , then  $X = 11$ , which has a remainder of 2 when divided by 9

The correct answer is D.

20.

If  $n$  is divisible by both 4 and 21, its prime factors include 2, 2, 3, and 7. Therefore, any integer that can be constructed as the product of these prime factors is also a factor of  $n$ . In this case, 12 is the only integer that can definitively be constructed from the prime factors of  $n$ , since  $12 = 2 \times 2 \times 3$ .

The correct answer is B.

**21.**

According to the information given,  $n=3k+2$ . Combined statement 1,  $n-2=5m$ , that is  $n=5m+2$ , we can obtain  $n=15p+2$ .

According to the information given,  $t=5s+3$ . Combined statement 2,  $t$  is divisible by 3, we can obtain  $t=15q+3$ .

$nt=(15p+2)(15q+3)=(15^2)pq+45p+30q+6$ , when divided by 15, the remainder is 6.

Answer is C

**22.**

1).  $N$  is odd, then  $n=2k+1$ ,  $n^2 - 1=(2k+1)^2-1=4k^2+4k=4k(k+1)$ . One of  $k$  and  $k+1$  must be even, therefore,  $4k(k+1)$  is divisible by 8.

Answer is A

**23.**

$4+7n=3+3n+3n+1+n=3(1+n)+3n+(1+n)$

From 1),  $n+1$  is divisible by 3, then  $4+7n$  is divisible by 3. Thus,  $r=0$

Answer is A

**24.**

1).  $n$  could be 22, 24, 26, ...insufficient

2).  $n=28K+3$ , then  $(28K+3)/7$ , the remainder is 3

Answer is B

**25.**

1). The general term is  $x=6k+3$ . So, the remainder is 3. [look for the "general term" in this page, you can find the explanation about it.]

2). The general term is  $x=12k+3$ . So, remainder is 3 as well.

Answer is D

26.

---

If  $x$  divided by 11 has a quotient of  $y$  and a remainder of 3,  $x$  can be expressed as  $x = 11y + 3$ , where  $y$  is an integer (by definition, a quotient is an integer). If  $x$  divided by 19 also has a remainder of 3, we can also express  $x$  as  $x = 19z + 3$ , where  $z$  is an integer.

We can set the two equations equal to each other:

$$11y + 3 = 19z + 3$$

$$11y = 19z$$

The question asks us what the remainder is when  $y$  is divided by 19. From the equation we see that  $11y$  is a multiple of 19 because  $z$  is an integer.  $y$  itself must be a multiple of 19 since 11, the coefficient of  $y$ , is not a multiple of 19.

If  $y$  is a multiple of 19, the remainder must be zero.

The correct answer is A

### Factors, Divisors, Multiples, LCM, HCF

1.

Since  $n$  must be a non-negative integer,  $n$  must be either a positive integer or zero. Also, note that the base of the exponent  $12^n$  is even and that raising 12 to the  $n^{\text{th}}$  exponent is equivalent to multiplying 12 by itself  $n$  number of times. Since the product of even integers is always even, the value of  $12^n$  will always be even as long as  $n$  is a positive integer. For example, if  $n = 1$ , then  $12^1 = 12$ ; if  $n = 2$ , then  $12^2 = 144$ , etc.

Since integer 3,176,793 is odd, it cannot be divisible by an even number. As a result, if  $n$  is a positive integer, then  $12^n$  (an even number) will never be a divisor of 3,176,793. However, if  $n$  is equal to zero, then  $12^n = 12^0 = 1$ . Since 1 is the only possible divisor of 3,176,793 that will result from raising 12 to a non-negative integer exponent (recall that all other outcomes will be even and thus will not be divisors of an odd integer), the value of  $n$  must be 0.

$$0^{12} - 12^0 = 0 - 1 = -1$$

The correct answer is B.

2. If the square root of  $p^2$  is an integer,  $p^2$  is a perfect square. Let's take a look at 36, an example of a perfect square to extrapolate some general rules about the properties of perfect squares.

Statement I: 36's factors can be listed by considering pairs of factors (1, 36) (2, 18) (3,12) (4, 9) (6, 6). We can see that they are 9 in number. In fact, for any perfect square, the number of factors will always be odd. This stems from the fact that factors can always be listed in pairs, as we have done above. For perfect squares, however, one of the pairs of factors will have an identical pair, such as the (6,6) for 36. The existence of this "identical pair" will always make the number of factors *odd* for any perfect square. Any number that is not a perfect square will automatically have an *even* number of factors. Statement I must be true.

Statement II: 36 can be expressed as  $2 \times 2 \times 3 \times 3$ , the product of 4 prime numbers. A perfect square will always be able to be expressed as the product of an even number of prime factors because a perfect square is formed by taking some integer, in this case 6, and squaring it. 6 is comprised of one two and one three. What happens when we square this number?  $(2 \times 3)^2 = 2^2 \times 3^2$ . Notice that each prime element of 6 will show up *twice* in  $6^2$ . In this way, the prime factors of a perfect square will always appear *in pairs*, so there must be an even number of them. Statement II must be true.

Statement III:  $p$ , the square root of the perfect square  $p^2$  will have an odd number of factors if  $p$  itself is a perfect square as well and an even number of factors if  $p$  is not a perfect square. Statement III is not necessarily true.

The correct answer is D, both statements I and II must be true.

3.

The greatest common factor (GCF) of two integers is the largest integer that divides both of them evenly (i.e. leaving no remainder).

One way to approach this problem is to test each answer choice:

Answer choice	$n$	GCF of $n$ and 16	GCF of $n$ and 45
(A)	6	2	3
(B)	8	8	1
(C)	9	1	9
<b>(D)</b>	<b>12</b>	<b>4</b>	<b>3</b>
(E)	15	1	15

Alternatively, we can consider what the GCFs stated in the question stem tell us about  $n$ :

The greatest common factor of  $n$  and 16 is 4. In other words,  $n$  and 16 both are evenly divisible by 4 (i.e., they have the prime factors  $2 \times 2$ ), but have absolutely no other factors in common. Since  $16 = 2 \times 2 \times 2 \times 2$ ,  $n$  must have exactly two prime factors of 2--no more, no less.

The greatest common factor of  $n$  and 45 is 3. In other words,  $n$  and 45 both are evenly divisible by 3, but have absolutely no other factors in common. Since  $45 = 3 \times 3 \times 5$ ,  $n$  must have exactly one prime factor of 3--no more, no less. Also,  $n$  cannot have 5 as a prime factor.

So,  $n$  must include the prime factors 2, 2, and 3. Additional prime factors are OK, as long as they do not include more 2s, more 3s, or any 5s.

- (A)  $6 = 2 \times 3$  missing a factor of 2
- (B)  $8 = 2 \times 2 \times 2$  missing a factor of 3, too many factors of 2
- (C)  $9 = 3 \times 3$  missing factors of 2, too many factors of 3
- (D)  $12 = 2 \times 2 \times 3$  OK
- (E)  $15 = 3 \times 5$  missing factors of 2, cannot have a factor of 5

The correct answer is D.

4.

The factors of 104 are  $\{1, 2, 4, 8, 13, 26, 52, 104\}$ . If  $x - 1$  is definitely one of these factors, OR if  $x - 1$  is definitely NOT one of these factors, then the statement is sufficient.

(1) INSUFFICIENT:  $x$  could be any one of the infinite multiples of 3. If  $x = 3$ ,  $x - 1$  would equal 2, which is a factor of 104. If  $x = 6$ ,  $x - 1$  would equal 5, which is not a factor of 104.

(2) INSUFFICIENT: The factors of 27 are  $\{1, 3, 9, 27\}$ . Subtracting 1 from each of these values yields the set  $\{0, 2, 8, 26\}$ . The non-zero values are all factors of 104, but 0 is not.

(1) AND (2) SUFFICIENT: Given that  $x$  is a factor of 27 and also divisible by 3,  $x$  must equal one of 3, 9 or 27.  $x - 1$  must therefore equal one of 2, 8, or 26 - all factors of 104.

The correct answer is C.

5.

$36^2$  can be expressed as the product of its prime factors, raised to the appropriate exponents:

$$36^2 = (2^2 \times 3^2)^2 = 2^4 \times 3^4$$

So, the prime box of  $36^2$  contains four 2's and four 3's, as shown:

2 2 2 2 3 3 3 3

Now, if you pick any combination of these primes and multiply them all together, the product will be a factor of  $36^2$ . As you take primes from this prime box to construct a factor of  $36^2$ , note that you can choose up to four 2's and up to four 3's. In fact, you have FIVE choices for the number of 2's you put into the factor: zero, one, two, three, or four 2's. Likewise, you have the same FIVE choices for the number of 3's you put into the factor: zero, one, two, three, or four. (It doesn't matter what order you pick the factors, since order doesn't matter in multiplication.)

Note that you are allowed to pick zero 2's and zero 3's at the same time. By doing so, you are constructing the factor  $2^0 \times 3^0 = 1$ , which is a separate, valid factor of  $36^2$ .

Since you have five independent choices for the number of 2's you pick AND you have five independent choices for the number of 3's you pick, you MULTIPLY the number of choices together to get the number of options you have overall. Thus you have  $5 \times 5 = 25$  different ways to construct a factor. This means that there are 25 different factors of  $36^2$ .

The correct answer is D.

6.

88,000 is the product of an unknown number of 1's, 5's, 11's and  $x$ 's. To figure out how many  $x$ 's are multiplied to achieve this product, we have to figure out what the value of  $x$  is. Remember that a number's prime box shows all of the prime factors that when multiplied together produce that number: 88,000's prime box contains one 11, three 5's, and six 2's, since  $88,000 = 11 \times 5^3 \times 2^6$ .

The 11 in the prime box must come from a red chip, since we are told that  $5 < x < 11$  and therefore  $x$  could not have 11 as a factor. In other words, the factor of 11 definitely did not come from the selection of a purple chip, so we can ignore that factor for the rest of our solution.

So, turning to the remaining prime factors of 88,000: the three 5's and six 2's. The 2's must come from the purple chips, since the other colored chips have odd values and thus no factor of two. Thus, we now know something new about  $x$ : it must be even. We already knew that  $5 < x < 11$ , so now we know that  $x$  is 6, 8, or 10.

However,  $x$  cannot be 6:  $6 = 2 \times 3$ , and our prime box has no 3's.

$x$  seemingly might be 10, because  $10 = 2 \times 5$ , and our prime box does have 2's and 5's. However, our prime box for 88,000 only has three 5's, so a maximum of three chips worth 10 points are possible. But that leaves three of the six factors of 2 unaccounted for, and we know those factors of two must have come from the purple chips.

So  $x$  must be 8, because  $8 = 2^3$  and we have six 2's, or two full sets of three 2's, in the prime box. Since  $x$  is 8, the chips selected must have been 1 red (one factor of 11), 3 green (three factors of 5), 2 purple (two factors of 8, equivalent to six factors of 2), and an indeterminate number of blue chips.

The correct answer is B.

7.

The problem asks us to find the greatest possible value of (length of  $x$  + length of  $y$ ), such that  $x$  and  $y$  are integers and  $x + 3y < 1,000$  (note that  $x$  and  $y$  are the numbers themselves, not the lengths of the numbers - lengths are always indicated as "length of  $x$ " or "length of  $y$ ," respectively).

Consider the extreme scenarios to determine our possible values for integers  $x$  and  $y$  based upon our constraint  $x + 3y < 1,000$  and the fact that both  $x$  and  $y$  have to be greater than 1. If  $y = 2$ , then  $x \leq 993$ . If  $x = 2$ , then  $y \leq 332$ . Of course,  $x$  and  $y$  could also be somewhere between these extremes.

Since we want the maximum possible sum of the lengths, we want to maximize the length of our  $x$  value, since this variable can have the largest possible value (up to 993). The greatest number of factors is calculated by using the smallest prime number, 2, as a factor as many times as possible.  $2^9 = 512$  and  $2^{10} = 1,024$ , so our largest possible length for  $x$  is 9.

If  $x$  itself is equal to 512, that leaves 487 as the highest possible value for  $3y$  (since  $x + 3y < 1,000$ ). The largest possible value for integer  $y$ , therefore, is 162 (since  $487 / 3 = 162$  remainder 1). If  $y < 162$ , then we again use the smallest prime number, 2, as a factor as many times as possible for a number less than 162. Since  $2^7 = 128$  and  $2^8 = 256$ , our largest possible length for  $y$  is 7.

If our largest possible length for  $x$  is 9 and our largest possible length for  $y$  is 7, our largest sum of the two lengths is  $9 + 7 = 16$ .

What if we try to maximize the length of the  $y$  value rather than that of the  $x$  value? Our maximum  $y$  value is 332, and the greatest number of prime factors of a number smaller than 332 is  $2^8 = 256$ , giving us a length of 8 for  $y$ . That leaves us a maximum possible value of 231 for  $x$  (since  $x + 3y < 1,000$ ). The greatest number of prime factors of a number smaller than 231 is  $2^7 = 128$ , giving us a length of 7 for  $x$ . The sum of these lengths is  $7 + 8 = 15$ , which is *smaller* than the sum of 16 that we obtained when we maximized the  $x$  value. Thus 16, not 15, is the maximum value of (length of  $x$  + length of  $y$ ).

The correct answer is D.

8.

The greatest common divisor is the largest integer that evenly divides both  $35x$  and  $20y$ .

(A) CAN be the greatest common divisor. First,  $35x / 5 = 7x$ , which is an integer for every possible value of  $x$ . Second,  $20y / 5 = 4y$ , which is an integer for every possible value of  $y$ . Therefore, 5 is a common divisor. It will be the greatest common divisor when  $7x$  and  $4y$  share no other factors. To illustrate, if  $x = 1$  and  $y = 1$ , then  $35x = 35$  and  $20y = 20$ , and their greatest common divisor is 5.

(B) CAN be the greatest common divisor. First,  $\frac{35x}{5(x-y)} = \frac{7x}{x-y}$ , which can be an integer

in certain cases: when  $x$  is a multiple of  $(x-y)$ . Second,  $\frac{20y}{5(x-y)} = \frac{4y}{x-y}$ , which can be an integer

in certain cases: when  $y$  is a multiple of  $(x-y)$ . So, this answer choice will be a divisor if both  $x$  and  $y$  are multiples of  $(x-y)$ . Since  $x$  and  $y$  are integers, the easiest way to meet the requirement is to select  $(x-y) = 1$ , for example  $x = 3$  and  $y = 2$ . To illustrate, if  $x = 3$  and  $y = 2$ , then  $35x = 105$  and  $20y = 40$ , and their greatest common divisor is  $5 = 5(x-y)$ .

(C) CANNOT be the greatest common divisor. Regardless of the values of  $x$  and  $y$ ,  $35x / 20x = 35/20 = 7/4$ , which is not an integer. Therefore,  $20x$  does not evenly divide one of the numbers in question. It is not a divisor, and certainly not the greatest common divisor.

(D) CAN be the greatest common divisor. First,  $35x / 20y = 7x / 4y$ , which can be an integer in certain cases: one such case is when  $x = 4$  and  $y = 1$ . Second,  $20y / 20y = 1$ , which is an integer. To illustrate, if  $x = 4$  and  $y = 1$ , then  $35x = 140$  and  $20y = 20$ , and their greatest common divisor is  $20 = 20y$ .

(E) CAN be the greatest common divisor. First,  $35x / 35x = 1$ , which is an integer. Second,  $20y / 35x = 4y / 7x$ , which can be an integer in certain cases: one such case is when  $x = 1$  and  $y = 7$ . To illustrate, if  $x = 1$  and  $y = 7$ , then  $35x = 35$  and  $20y = 140$ , and their greatest common divisor is  $35 = 35x$ .

The correct answer is C.

### 9.

Let's begin by analyzing the information given to us in the question:

$$\frac{P}{Q} = \frac{R}{S}$$

If  $P$ ,  $Q$ ,  $R$ , and  $S$  are positive integers, and  $\frac{P}{Q} = \frac{R}{S}$ , is  $R$  divisible by 5?

It is often helpful on the GMAT to rephrase equations so that there are no denominators. We can do this by cross-multiplying as follows:

$$\frac{P}{Q} = \frac{R}{S} \rightarrow PS = RQ$$

Now let's analyze Statement (1) alone:  $P$  is divisible by 140.

Most GMAT divisibility problems can be solved by breaking numbers down to their prime factors (this is called a "prime factorization").

The prime factorization of 140 is:  $140 = 2 \times 2 \times 5 \times 7$ .

Thus, if  $P$  is divisible by 140, it is also divisible by all the prime factors of 140. We know that  $P$  is divisible by 2 twice, by 5, and by 7. However, this gives us no information about  $R$  so Statement (1) is not sufficient to answer the question.

Next, let's analyze Statement (2) alone:  $Q = 7^x$ , where  $x$  is a positive integer.

From this, we can see that the prime factorization of  $Q$  looks something like

this:  $Q = 7 \times 7 \times 7 \dots$ . Therefore, we know that 7 is the only prime factor of  $Q$ . However, this gives us no information about  $R$  so Statement (2) is not sufficient to answer the question.

Finally, let's analyze both statements taken together:

From Statement (1), we know that  $P$  has 5 as one of its prime factors. Since 5 is a factor of  $P$  and since  $P$  is a factor of  $PS$ , then by definition, 5 is a factor of  $PS$ .

Recall that the question told us that  $PS = QR$ . From this, we can deduce that  $PS$  must have the same factors as  $QR$ . Since 5 is a factor of  $PS$ , 5 must also be a factor of  $QR$ .

From Statement (2), we know that 7 is the only prime factor of  $Q$ . Therefore, we know that 5 is NOT a factor of  $Q$ . However, we know that 5 must be a factor of  $QR$ . The only way this can be the case is if 5 is a factor of  $R$ .

Thus, by combining both statements we can answer the question: Is  $R$  divisible by 5? Yes, it must be divisible by 5. Since BOTH statements TOGETHER are sufficient, but NEITHER statement ALONE is sufficient, the correct answer is C.

### 10.

We are asked whether  $y$  is a common divisor of  $x$  and  $w$ . In other words, is  $y$  a factor of both  $x$  and  $w$ ?

Statement (1) tells us that  $\frac{w}{x} = \frac{1}{z} + \frac{1}{x}$ . Since  $w$  is greater than  $x$ , the quotient  $\frac{w}{x}$  must be greater than 1. For example,  $\frac{17}{6} = 2\frac{5}{6}$ .

Since  $\frac{w}{x}$  is greater than 1, the other side of the equation must be greater than 1 as well. In this case, since  $x$  and  $z$  are integers,  $\frac{1}{z} + \frac{1}{x}$  cannot be greater than 1 unless either  $x$  or  $z$  is equal to 1.  $x$  cannot be equal to 1 because at least two integers ( $y$  and  $z$ ) stand between it and 0 on the number line. So  $z$  must equal 1. We can now rewrite the equation as  $\frac{w}{x} = 1 + \frac{1}{x}$ . At this point, we can finish up using algebra:

$$\begin{aligned} \frac{w}{x} &= 1 + \frac{1}{x} \rightarrow \\ w &= x + \frac{x}{x} \rightarrow \\ w &= x + 1 \end{aligned}$$

If  $w = x + 1$ , then  $w$  and  $x$  must be consecutive integers. Since the distance between two consecutive integers is always 1, no number other than 1 can be a factor of both. Note, for example, that all multiples of 2 are at least 2 spaces apart, all multiples of 3 are at least 3 spaces apart, and so on. So in order for  $y$  to be a common factor of  $w$  and  $x$ , it would have to equal 1. But because  $y$  is greater than 1 (at least 1 integer stands between it and 0 on the number line), it cannot be a common divisor of  $w$  and  $x$ . Thus, statement (1) alone is sufficient to answer the question.

Statement (2) gives us an equation that we can factor into  $w(w - y - 2) = 0$ . This implies that either  $w$  or  $(w - y - 2)$  is equal to 0. We know that  $w$  is greater than 0, so it must be true that  $(w - y - 2) = 0$ . We can add  $y$  and 2 to both sides to get  $w = y + 2$ . So  $w$  is 2 greater than  $y$  on the number line. Since  $x$  falls between  $w$  and  $y$ , we know that  $w$ ,  $x$ , and  $y$  are consecutive integers. No integer greater than 1 can be a factor of the two integers that follow it on the number line. Since  $y$  is greater than 1, it cannot be a factor of both  $w$  and  $x$ . Thus, statement (2) alone is sufficient to answer the question.

The answer is D: Each statement ALONE is sufficient to answer the question.

## 11.

The question tells us that  $(a + b)(c - d) = r$ , where  $r$  is an integer, and then asks whether  $\sqrt{c + d}$  is an integer. In order for  $\sqrt{c + d}$  to be an integer,  $(c + d)$  must be the square of an integer.

Statement (1) tells us that  $(a + b)(c + d) = r^2$ . Therefore,  $(a + b)(c + d) = (a + b)^2(c - d)^2$ . If we divide both sides of the equation by  $(a + b)$ , we get  $(c + d) = (a + b)(c - d)^2$ . Is this sufficient to determine whether  $(c + d)$  is the square of an integer? No. Since  $(c - d)^2$  is a

square,  $(a + b)$  must also be a square in order for  $(c + d)$  to be a square. We do not know whether  $(a + b)$  is a square, so this statement is insufficient.

Statement (2) tells us that the prime factorization of  $(a + b)$  is  $x^4y^6z^2$ . This does not tell us anything about  $(c + d)$ , so it must be insufficient.

If we combine the information from both statements, we know that  $(c + d) = (a + b)(c - d)^2$  and that  $(a + b) = x^4y^6z^2$ . In order for the information from statement (1) to be sufficient, we would need to know that  $(a + b)$  is itself a square. Knowing that the prime factorization of  $(a + b)$  is  $x^4y^6z^2$  tells us that it must be true that  $(a + b)$  is a square, because all of its prime factors come in pairs. Any integer that has an even number of each of its prime factors must be a square. We can see this by expressing  $(a + b)$  as  $(a + b) = (x^2y^3z)(x^2y^3z)$ .

Therefore,  $(c + d)$  must be a square and  $\sqrt{(c + d)}$  must be an integer.

The correct answer is C: Taken together, the statements are sufficient, but neither statement alone is sufficient.

12.

Any product  $pq$  must have the following factors:  $\{1, p, q, \text{ and } pq\}$ . If the product  $pq$  has no additional factors, the  $p$  and  $q$  must be prime.

Statement (1) tells us that the sum of  $p$  and  $q$  is an odd integer. Therefore either  $p$  or  $q$  must be even, while the other is odd. Since we know  $p$  and  $q$  are prime, either  $p$  or  $q$  must be equal to 2 (the only even prime number). However, statement (1) does not provide enough information for us to know which of the variables,  $p$  and  $q$ , is equal to 2.

Statement (2) tells us that  $q < p$ , which does not give us any information about the value of  $p$ . From both statements taken together, we know that, since 2 is the smallest prime number,  $q$  must equal 2. However, we cannot determine the value of  $p$ .

The correct answer is E.

13.

(1) SUFFICIENT: Since  $x$  and  $y$  are distinct prime numbers (we know that  $x < y$ ), their sum must be greater than or equal to 5 (i.e. greater than or equal to the sum of the two smallest primes, 2 and 3). Further, the factors of 57 are 1, 3, 19, and 57. Note that the sum of  $x$  and  $y$  cannot be equal to 57, since if the sum of two distinct primes is odd, one of the two primes must be even (i.e. equal to 2). Since 55 (i.e.  $57 - 2$ ) is not a prime number, 57 cannot be equal to the sum of two primes.

Since we already figured that the sum of two distinct primes must exceed 5, the only factor of 57 that can be equal to the sum of two primes is 19. Again, since the sum of the two primes is odd, one of the primes must be even. Thus,  $x = 2$  and  $y = 19 - 2 = 17$ . Finally, since we know that  $x$  is even, it cannot be a factor of the odd integer  $z$ , since any even integer is never a factor of any odd integer. Therefore, we have sufficient information to conclude that  $x$  will not be a factor of  $z$ .

(2) INSUFFICIENT: First, note that  $z$  has to be greater than or equal to 3 (recall that  $x < y < z$ , where  $x$ ,  $y$ , and  $z$  are positive integers). Thus, since the factors of 57 are 1, 3, 19, and 57, it follows that  $z$  can be equal to 3, 19, or 57. Since we have no further information about  $x$ , we

cannot conclude whether  $x$  is a factor of  $z$ .

The correct answer is A.

**14.**

Let's start by breaking 80 down into its prime factorization:  $80 = 2 \times 2 \times 2 \times 2 \times 5$ . If  $p^3$  is divisible by 80,  $p^3$  must have 2, 2, 2, 2, and 5 in its prime factorization. Since  $p^3$  is actually  $p \times p \times p$ , we can conclude that the prime factorization of  $p \times p \times p$  must include 2, 2, 2, 2, and 5.

Let's assign the prime factors to our  $p$ 's. Since we have a 5 on our list of prime factors, we can give the 5 to one of our  $p$ 's:

$p$ : 5  
 $p$ :  
 $p$ :

Since we have four 2's on our list, we can give each  $p$  a 2:

$p$ :  $5 \times 2$   
 $p$ : 2  
 $p$ : 2

But notice that we still have one 2 leftover. This 2 must be assigned to one of the  $p$ 's:

$p$ :  $5 \times 2 \times 2$   
 $p$ : 2  
 $p$ : 2

We must keep in mind that each  $p$  is equal in value to any other  $p$ . Therefore, all the  $p$ 's must have exactly the same prime factorization (i.e. if one  $p$  has 5 as a prime factor, all  $p$ 's must have 5 as a prime factor). We must add a 5 and a 2 to the 2nd and 3rd  $p$ 's:

$p$ :  $5 \times 2 \times 2 = 20$   
 $p$ :  $5 \times 2 \times 2 = 20$   
 $p$ :  $5 \times 2 \times 2 = 20$

We conclude that  $p$  must be at least 20 for  $p^3$  to be divisible by 80. So, let's count how many factors 20, or  $p$ , has:

$1 \times 20$   
 $2 \times 10$   
 $4 \times 5$

20 has 6 factors. If  $p$  must be at least 20,  $p$  has at least 6 distinct factors.

The correct answer is C.

**15.**

Any integer can be broken down into prime factors, and these prime factors can be used to find the total number of factors. The factors of 12, for example, can be found by listing all of the different combinations of 12's prime factors, 2, 2 and 3, viz., 1, 2, 3, 4, 6, 12. Another way to list the factors of 12, however, is to simply consider, by pairs, all of the numbers that divide 12

evenly. Start the list with 1 and the number itself and then search for other pairs by increasing by increments of 1. For 12, you easily come across two other pairs of distinct factors: (2,6) and (3,4). In this way, the factors of any reasonably sized integer can be listed and counted. This question is asking if  $p$  an odd number of distinct factors. This begs the question: if factors of an integer can always be listed in factor pairs, how could an integer ever have anything other than an even number of factors? Let's look at the two statements to shed some light on the issue. Statement (1) tells us that  $p$  is a perfect square, i.e. a number that when you take its square root, the result is an integer. Let's take 36 to investigate. Any perfect square will have an even number of *prime factors* when you break it down. What effect does this have on the number of *factors* however? Well if we resort to our listing of pairs we have: (1,36), (2,18), (3,12), (4,9) and (6,6). As always, the factors can be listed in pairs. However, in this example one of the pairs has a single factor that is *repeated*, i.e. (6,6). When we count the total number of distinct factors of 36, the answer is nine - an odd number. In fact, this will be true for any perfect square because one (and only one) of the factor pairs will have a single factor repeated twice. The converse is also true - non-perfect square integers will always have an even number of factors, since none of the factor pairs will have a repeated integer. Statement (1) is sufficient so the answer is either (A) or (D). If we look at statement (2), it tells us that  $p$  is an odd integer. Knowing that  $p$  is odd, however, doesn't tell us if the number of factors is odd or even. Odd numbers that are perfect squares would have an odd number of factors ( $9 = 1, 3$  and  $9$ ) and odd numbers that are not perfect squares would have an even number of factors ( $15 = 1, 3, 5$  and  $15$ ). Statement (2) is not sufficient and the answer is (A). This problem could also be solved by plugging legal values based on the two statements to see if they are sufficient to answer the question. When evaluating the sufficiency of statement (1), it would be best to try perfect squares that are both odd and even to see if all perfect squares have an odd number of factors. When evaluating the sufficiency of statement (2), it would be best to try odd numbers that are both perfect squares and not to see if all odd numbers have an odd number of factors.

### 16.

(1) INSUFFICIENT: For a number to be divisible by 16, it must be divisible by 2 four times. The expression  $m(m + 1)(m + 2) \dots (m + n)$  represents the product of  $n + 1$  consecutive integers. For example if  $n = 5$ , the expression represents the product of 6 consecutive integers.

To find values of  $n$  for which the product will be divisible by 16 let's first consider  $n = 3$ . This implies a product of four consecutive integers. In any set of four consecutive integers, two of the integers will be even and two will be odd. In addition one of the two even integers will be a multiple of 4, since every other *even* integer on the number line is a multiple of 4 (4 yes, 6 no, 8 yes, etc...). This accounts for a total of *three* 2's that can definitely divide into the product of 4 consecutive integers. This however is not enough.

With five integers (i.e.  $n = 4$ ), there *may or may not* be an additional 2: there could be two or three even integers. Six integers (i.e.  $n = 5$ ) will guarantee three even integers and a product that is divisible by four 2's. Anything above six integers will naturally be divisible by 16 as well, so we can conclude that  $n$  is greater than or equal to 5.

(2) INSUFFICIENT: This expression factors to  $(n - 4)(n - 5) = 0$ . There are two solutions for  $n$ , 4 or 5.

(1) AND (2) TOGETHER SUFFICIENT: If  $n$  must be greater than or equal to 5 and either 4 or 5, then  $n$  must be equal to 5.

The correct answer is C.

### 17.

$$\frac{n^2}{n}$$

The question stem states that  $\frac{n^2}{n}$  yields an integer greater than 0, which can be simplified to state that  $n$  is an integer. The question can be rephrased as follows: Does the integer  $n$  have 2, 3, and 5 as prime factors?

Statement (1) tells us that  $n^2$  is divisible by 20. Thus,  $n^2$  has 2, 2, and 5 as its prime factors. What does this tell us about  $n$ ? Since we know that  $n$  is an integer,  $n^2$  must be a perfect square. The prime factors of any perfect square come in pairs.

For example, the perfect square 36 can be broken down into  $2 \times 2 \times 3 \times 3$ , or a pair of 2's and a pair of 3's. Taking one prime from each pair, yields  $2 \times 3$ , or 6, the integer root of the perfect square 36.

Since we are told in Statement (1) that  $n^2$  has 2, 2, and 5 as its prime factors we can assume that  $n^2$  actually has a pair of 2's and **a pair** of 5's as well (remember, all perfect squares can be broken into pairs of primes). Thus, taking one prime from each pair, we know that  $n$  must be divisible by 2 and 5. However, this is not sufficient to answer the question, since we do not know whether or not  $n$  is divisible by 3.

Statement (2) tells us that  $n^3$  is divisible by 12. Thus  $n^3$  must have 2, 2, and 3 as its prime factors. We also know that, since  $n$  is an integer,  $n^3$  is a perfect cube. Using the same logic as in the previous statement,  $n^3$  must be divisible by a triplet of 2's and a triplet of 3's. Taking one prime from each triplet, we know that  $n$  must be divisible by 2 and 3. However, this is not sufficient to answer the question since we do not know whether or not  $n$  is divisible by 5. Taking both statements together, we know that  $n$  is divisible by 2, 3, and 5. Therefore  $n$  is divisible by 30.

The correct answer is (C): BOTH statements TOGETHER are sufficient, but NEITHER statement ALONE is sufficient.

18.

First, let's rephrase the complex wording of this question into something easier to handle. The question asks whether  $x$  is a non-integer which is the reverse of an easier question: Is  $x$  an integer?

Surely, if we can answer this question, we can answer the original question.

We can isolate  $x$  by rewriting the given equation as follows:  $x = \frac{ab}{30}$ .

In order for  $x$  to be an integer,  $ab$  must be divisible by 30. In order for a number to be divisible by 30, it must have 2, 3, and 5 as prime factors (since  $30 = 2 \times 3 \times 5$ ).

Thus, the question becomes: Does  $ab$  have 2, 3, and 5 as prime factors?

We know from the question that  $a$  and  $b$  are consecutive positive integers. Thus, either  $a$  or  $b$  is an even number, which means that the product  $ab$  must be divisible by 2.

Since we know that 2 is a prime factor of  $ab$ , the question can be further simplified: Does  $ab$  have 3 and 5 as prime factors?

Statement (1) tells us that 21 is a factor of  $a^2$  which means that 3 and 7 are prime factors of  $a^2$ .

We can deduce from this that 3 and 7 must also be factors of  $a$  itself. (How? We know that  $a$  is a positive integer, which means that  $a^2$  is a perfect square. All prime factors of perfect squares come in pairs. Thus, if  $a^2$  is divisible by 3, then  $a^2$  must be divisible by a pair of 3's, which means that  $a$  itself must be divisible by at least *one* 3. You can test this using a real value for  $a^2$ .)

Knowing that 3 is a prime factor of  $a$  tells us that 3 is a factor of  $ab$  but is not sufficient to answer our rephrased question, since we know nothing about whether 5 is a factor of  $ab$ .

Statement (2) tells us that 35 is a factor of  $b^2$  which means that 5 and 7 are prime factors of  $b^2$ .

Using the same logic as for the previous statement, we can deduce that 5 and 7 must be factors of  $b$  itself. Knowing that 5 is a prime factor of  $b$  tells us that 5 is a factor of  $ab$  but it is not sufficient to answer our rephrased question, since we know nothing about whether 3 is a factor of  $ab$ .

If we combine both statements, we know that  $ab$  must be divisible by both 3 and 5, which is sufficient information to answer the original question. The correct answer is C: BOTH statements TOGETHER are sufficient, but NEITHER statement ALONE is sufficient.

### 19.

Divisibility problems can be solved using prime factorization.

The prime factorization of  $504 = 2^3 3^2 7$ .

Therefore, using the given equation, we can see that:

$$\begin{aligned}\sqrt{ABC} &= 504 = 2^3 3^2 7 \\ (\sqrt{ABC})^2 &= (2^3 3^2 7)^2 \\ ABC &= 2^6 3^4 7^2\end{aligned}$$

To answer the question, we must determine whether  $B$  contains *one* of the six 2's in the prime factorization.

Statement (1) alone tells us that  $C = 168 = 2^3(3)(7)$ .

This tells us that  $C$  has *three* of the 2's in the prime factorization. However, since we have no information about  $A$  or  $B$ , this is not sufficient information to answer the question.

Statement (2) alone tells us that  $A$  is a perfect square.

This tells us that if  $A$  contains any 2's as prime factors, it must have an even number of 2's. (The only way a number can be a perfect square is if its prime factors come in pairs). This, again is not sufficient information to answer the question.

Using both statements together, we know that  $C$  has *three* of the 2's. We also know that  $A$  can have either *zero* of the 2's or *two* of the 2's, but, since  $A$  is a perfect square, it cannot have all *three* of the remaining 2's.

Thus, **B** must have at least one 2 as a prime factor. The correct answer is C.

20.

An integer is "divisible" by a number if the integer can be divided evenly by that number (meaning that there is no remainder). For example, 15 is divisible by 3 because it can be divided evenly by 3 ( $15/3 = 5$ ), but 15 is not divisible by 4 ( $15/4 = 3$  r. 3).

One way to answer this question is to test each answer choice. The smallest integer that is divisible by 12, 11, 10, 9, and 8 will be the correct answer.

(A) 7,920 is divisible by every value on the list.

(B) 5,940 IS NOT divisible by 8.

(C) 3,960 IS divisible by every value on the list.

(D) 2,970 IS NOT divisible by 12 or 8.

(E) 890 IS NOT divisible by 12, 11, 9, or 8.

Alternatively, the least common multiple can be calculated directly. Consider the prime factors of the numbers on our list:

$$12 = 2^2 \times 3$$

$$11 = 11^1$$

$$10 = 2^1 \times 5^1$$

$$9 = 3^2$$

$$8 = 2^3$$

The smallest integer that is divisible by 12, 11, 10, 9, and 8 will have the prime factors that appear in the list above, but no more of each than is necessary. In order to be divisible by 8, we need three 2's. In order to be divisible by 9, we need two 3's. In order to be divisible by 10, we need one 2 and one 5. But since we already have three 2's in the 8, we need only the 5. In order to be divisible by 11, we need the entire 11 (because it is prime). In order to be divisible by 12, we need two 2's and one 3, but since we already have three 2's in the 8 and two 3's in the 9, we do not need to take any more.

Thus, the integer will have the following prime factors: three 2s, two 3s, one 5, and one 11.

$$2^3 \times 3^2 \times 5 \times 11 = 3,960$$

The correct answer is C.

21.

The question stem tells us that  $x$  is a positive integer. Then we are asked whether  $x$  is prime; it is helpful to remember that all prime numbers have exactly two factors. Since we cannot rephrase the question, we must go straight to the statements.

(1) SUFFICIENT: If  $x$  has the same number of factors as  $y^2$ , then  $x$  cannot be prime. A prime number is a number that has only itself and 1 as factors. But a square has at least 3 prime factors. For example, if  $y$  is prime,  $y = 2$ , then  $y^2 = 4$ , which has 1, 2, and 4 as factors. If the

root (in this case  $y$ ) is not prime, then the square will have more than 3 factors. For example, if  $y = 4$ , then  $y^2 = 16$ , which has 1, 2, 4, 8, and 16 as factors. In either case,  $x$  will have at least 3 factors, establishing it as nonprime.

(2) INSUFFICIENT: If  $z$  is prime, then  $x$  will have only two factors, making it prime. But if  $z$  is nonprime, it will have either one (if  $z = 1$ ) or more than two factors, which means  $x$  will have either one or more than two factors, making  $x$  nonprime. Since we do not know which case we have, we cannot tell whether  $x$  is prime.

The correct answer is A.

**22.**

We have 5,10,15,20,25,30 and some 2s to see how many zeros there are in the tail of the result  $5 \times 2$ ,  $15 \times 2$  contributes 1 zero each

10, 20, 30  $\Rightarrow$  3 zeros

$25 \times 4 \Rightarrow$  be careful, it contributes 2 zeros

So totally there are  $1 \times 2 + 3 + 2 = 7$  zeros in the tails of 30!

For 1,  $d$  can be 1,2,3,4,5,6,7

For 2,  $d$  can be any integer  $> 6$

Together,  $d$  can only be 7 to fulfill both requirements.

Answer is C

**23.**

For 1),  $x = 3y^2 + 7y = y(3y + 7)$ ,  $x$  must be a multiple of  $y$

For 2),  $x^2 - x = x(x - 1)$  is multiple of  $y$ , does not mean that  $x$  is a multiple of  $y$ . For example:  $x = 7$ ,  $y = 3$

24:

The least prime number is 2. We notice that  $2^6 = 64$  and  $2^5 \cdot 3 = 96$ . Any 2 combined, the number will be greater than 100. So, only 64 and 96 fulfill the requirement.

So, answer is 2

**25.**

1).  $n = k_1 \cdot 5$ ;  $t = k_2 \cdot 5$  ( $k_1, k_2$  are natural numbers),  $n \cdot t = k_1 \cdot k_2 \cdot 5^2$ .  $k_1$  and  $k_2$  are unknown, thus, we cannot obtain the greatest prime factor of  $nt$ .

2).  $105 = 1 \cdot 3 \cdot 5 \cdot 7$ .

The least common multiple of  $n$  and  $t$  is 105  $\Rightarrow$  the greatest value of  $n$  and  $t$  is 105, and the other one must be less than 105 and be composed with numbers of 1, 3, 5, 7.

So, the greatest prime factor is 7

Answer is B

**26.**

1).  $xy$  is even, means that  $x$  or  $z$  is even. If  $x$  is even, then  $y$  is even, then  $z$  is even. Statement 1 is sufficient.

2).  $Y$  is even then  $z$  is even.

Answer is D

**27.**

1).  $K$  is prime,  $20K = 2^2 \cdot 5 \cdot K$ ,  $k$  could be 2, 5, or other prime, so, number of the different prime factors of  $20k$  can not be determined.

2).  $K = 7$ ,  $20k = 2^2 \cdot 5 \cdot 7$ , has 3 different prime factors.

Answer is B

**28.**

$$4^{17} = (2^2)^{17} = 2^{34}$$

$$2^{34} - 2^{28} = 2^{28}(2^6 - 1) = 2^{28} \cdot 63 = 2^{28} \cdot 7 \cdot 3^2$$

Answer is 7

**29.**

1). When  $n$  is 105, or 210,  $2n$  has four different prime factors: 2, 3, 5, 7, but 105 has 3 prime factors, and 210 has 4 prime factors.

2). Sufficient.

Answer is B

30.

(1) INSUFFICIENT:  $a$  and  $b$  could be 12 and 8, with a greatest common factor of 4; or they could be 11 and 7, with a greatest common factor of 1.

(2) INSUFFICIENT: This statement tells us that  $b$  is a multiple of 4 but we have no information about  $a$ .

(1) AND (2) SUFFICIENT: Together, we know that  $b$  is a multiple of 4 and that  $a$  is the next consecutive multiple of 4. For any two positive consecutive multiples of an integer  $n$ ,  $n$  is the greatest common factor of those multiples, so the greatest common factor of  $a$  and  $b$  is 4.

The correct answer is C

---

31.

The first 7 integer multiples of 5 are 5, 10, 15, 20, 25, 30, and 35. The question is asking for the least common multiple (LCM) of these 7 numbers. Let's construct the prime box of the LCM.

In order for the LCM to be divisible by 5, one **5** must be in the prime box.

In order for the LCM to be divisible by 10, a 5 (already in) and a **2** must be in the prime box.

In order for the LCM to be divisible by 15, a 5 (already in) and a **3** must be in the prime box.

In order for the LCM to be divisible by 20, a 5 (already in), a 2 (already in), and a second **2** must be in the prime box.

In order for the LCM to be divisible by 25, a 5 (already in) and a second **5** must be in the prime box.

In order for the LCM to be divisible by 30, a 5 (already in), a 2 (already in) and a 3 (already in) must be in the prime box.

In order for the LCM to be divisible by 35, a 5 (already in) and a **7** must be in the prime box. Thus, the prime box of the LCM contains a 5, 2, 3, 2, 5, and 7. The value of the LCM is the product of these prime factors, 2100.

The correct answer is D.

## Consecutive Integers

1.

The quadratic expression  $k^2 + 4k + 3$  can be factored to yield  $(k + 1)(k + 3)$ . Thus, the expression in the question stem can be restated as  $(k + 1)(k + 2)(k + 3)$ , or the product of three consecutive integers. This product will be divisible by 4 if one of two conditions are met:

If  $k$  is odd, both  $k + 1$  and  $k + 3$  must be even, and the product  $(k + 1)(k + 2)(k + 3)$  would be divisible by 2 twice. Therefore, if  $k$  is odd, our product must be divisible by 4.

If  $k$  is even, both  $k + 1$  and  $k + 3$  must be odd, and the product  $(k + 1)(k + 2)(k + 3)$  would be divisible by 4 only if  $k + 2$ , the only even integer among the three, were itself divisible by 4.

The question might therefore be rephrased "Is  $k$  odd, OR is  $k + 2$  divisible by 4?" Note that a 'yes' to either of the conditions would suffice, but to answer 'no' to the question would require a 'no' to both conditions.

(1) SUFFICIENT: If  $k$  is divisible by 8, it must be both even and divisible by 4. If  $k$  is divisible by 4,  $k + 2$  cannot be divisible by 4. Therefore, statement (1) yields a definitive 'no' to both conditions in our rephrased question;  $k$  is not odd, and  $k + 2$  is not divisible by 4.

(2) INSUFFICIENT: If  $k + 1$  is divisible by 3,  $k + 1$  must be an odd integer, and  $k$  an even integer. However, we do not have sufficient information to determine whether  $k$  or  $k + 2$  is divisible by 4.

The correct answer is A.

2.

One way to approach this problem is to test the values given in the answer choices.

	Product	Product when x =							
K	$x(x - 1)(x - k)$	0	1	2	3	4	5	Comments	
-4	$x(x - 1)(x + 4)$	0	0	(2)(1)(6)	(3)(2)(7)	(4)(3)(8)	(5)(4)(9)	always divisible by 3	
-2	$x(x - 1)(x + 2)$	0	0	<b>(2)(1)(4)</b>	(3)(2)(5)	(4)(3)(6)	<b>(5)(4)(7)</b>	NOT always divisible by 3	
-1	$x(x - 1)(x + 1)$	0	0	(2)(1)(3)	(3)(2)(4)	(4)(3)(5)	(5)(4)(6)	always divisible by 3	
2	$x(x - 1)(x - 2)$	0	0	(2)(1)(0)	(3)(2)(1)	(4)(3)(2)	(5)(4)(3)	always divisible by 3	
5	$x(x - 1)(x - 5)$	0	0	(2)(1)(-3)	(3)(2)(-2)	(4)(3)(-1)	(5)(4)(0)	always divisible by 3	

Alternatively, use the rule that the product of three consecutive integers will always be a multiple of three. The rule applies because any three consecutive integers will always include one multiple of three. So, if  $(x)$ ,  $(x - k)$  and  $(x - 1)$  are consecutive integers, then their product must be

divisible by three. Note that  $(x)$  and  $(x-1)$  are consecutive, so the three terms would be consecutive if  $(x-k)$  is either the lowest of the three, or the greatest of the three:

$(x-k), (x-1),$  and  $(x)$  are consecutive when  $(x-k) = (x-2)$ , or  $k = 2$   
 $(x-1), (x),$  and  $(x-k)$  are consecutive when  $(x-k) = (x+1)$ , or  $k = -1$

Note that the difference between  $k = -1$  and  $k = 2$  is 3. Every third consecutive integer would serve the same purpose in the product  $x(x-1)(x-k)$ : periodically serving as the multiple of three in the list of consecutive integers. Thus,  $k = -4$  and  $k = 5$  would also give us a product that is always divisible by three.

The correct answer is B.

3.

The question is in very simple form already; rephrasing the question isn't useful. The statements, however, can be rephrased.

Statement (1) gives the formula  $n^3 - n$ . We can first factor out an  $n$  to get  $n(n^2 - 1)$ . Next, we can factor  $(n^2 - 1)$  to get  $(n+1)(n-1)$ . So,  $n^3 - n$  factors to  $n(n+1)(n-1)$ . Notice that the three factored terms represent consecutive integers:  $n-1, n,$  and  $n+1$ .

Now, let's rephrase statement (2). We first factor out an  $n$  to get  $n(n^2 + 2n + 1)$ . Next, we can factor  $(n^2 + 2n + 1)$  to get  $(n+1)(n+1)$ . So,  $n^3 + 2n^2 + n$  factors to  $n(n+1)(n+1)$ . Notice that the factored terms represent two consecutive integers, with the larger of the two represented twice.

(1) INSUFFICIENT:  $(n-1)(n)(n+1)$  is a multiple of 3. Any three consecutive positive integers include exactly one multiple of 3 (if you don't remember this rule, try some real numbers and prove it to yourself). Of the three terms  $n-1, n,$  and  $n+1$ , one is a multiple of 3 but we have no way to determine which one.

(2) SUFFICIENT:  $n(n+1)(n+1)$  is a multiple of 3. This tells us that either  $n$  or  $n+1$  is a multiple of 3. The question asks whether the term  $n-1$  is a multiple of 3. Recall that  $n-1, n,$  and  $n+1$  represent three consecutive integers and also recall that any three consecutive integers include exactly one multiple of 3. Note that we do not need to get this information from statement (1). If the multiple of 3 is either the  $n$  or the  $n+1$  term, then the  $n-1$  term cannot be a multiple of 3.

The correct answer is B.

4.

Since the product of  $b, c,$  and  $d$  is equal to twice that of  $a, b,$  and  $c$ , we can set up an equation and discover something about the relationship between  $d$  and  $a$ :

$$bcd = 2abc$$
$$d(bc) = 2a(bc)$$

Note that  $bc$  appears on both sides of the equation. It is multiplied by  $d$  on the left side, and by  $2a$  on the right side. Since the left side of the equation must equal the right side of the equation:

$$d = 2a$$

Since  $a, b, c,$  and  $d$  are consecutive integers,  $d$  must be 3 more than  $a$ , or:

$$d = a + 3$$

We can combine both equations and solve for  $a$ :

$$2a = a + 3$$
$$a = 3$$

If  $a = 3$ , we know that  $b = 4$ ,  $c = 5$ , and  $d = 6$ . Therefore,  $bc = (4)(5) = 20$ .

The correct answer is D.

### 5.

First, note that a product of three consecutive positive integers will always be divisible by 8 if the set of these integers contains 2 even terms. These two even terms will represent consecutive multiples of 2 (note that  $z = x + 2$ ), and since every other multiple of 2 is also a multiple of 4, one of these two terms will always be divisible by 4. Thus, if one of the two even terms is divisible by 4 and the other even term is divisible by 2 (since it is even), the product of 3 consecutive positive terms containing 2 even numbers will always be divisible by 8. Therefore, to address the question, we need to determine whether the set contains 2 even terms. In other words, the remainder from dividing  $xyz$  by 8 will depend on whether  $x$  is even or odd.

(1) SUFFICIENT: This statement tells us that the product  $xz$  is even. Note that since  $z = x + 2$ ,  $x$  and  $z$  can be only both even or both odd. Since their product is even, it must be that both  $x$  and  $z$  are even. Thus, the product  $xyz$  will be a multiple of 8 and will leave a remainder of zero when divided by 8.

(2) SUFFICIENT: If  $5y^3$  is odd, then  $y$  must be odd. Since  $y = x + 1$ , it must be that  $x = y - 1$ . Therefore, if  $y$  is odd,  $x$  is even, and the product  $xyz$  will be a multiple of 8, leaving a remainder of zero when divided by 8.

The correct answer is D.

### 6.

If we factor the equation in the question, we get  $n = x(x - 1)(x + 1)$  or  $n = (x - 1)x(x + 1)$ .  $n$  is the product of three consecutive integers. What would it take for  $n$  to be divisible by 8? To be divisible by 8,  $n$  is to be divisible by 2 three times, or to have three 2's in the prime box.

The easiest way for this to happen is if  $x$  is odd. If  $x$  is odd, both  $x - 1$  and  $x + 1$  will be even or divisible by 2. Furthermore, if  $x$  is odd,  $x - 1$  and  $x + 1$  will also be *consecutive* even integers. Among *consecutive* even integers, every other even integer is divisible not only by 2 but also by 4. Thus, either  $x - 1$  or  $x + 1$  must be divisible by 4. With one number divisible by 2 and the other by 4, the product represented by  $n$  will be divisible by 8 if  $x$  is odd.

(1) SUFFICIENT: This tells us that  $x$  is odd. If  $3x$  divided by 2 has a remainder,  $3x$  is odd. If  $3x$  is odd,  $x$  must be odd as well.

(2) SUFFICIENT: This statement tells us that  $x$  divided by 4 has a remainder of 1. This also tells us that  $x$  is odd because an even number would have an even remainder when divided by 4.

Alternative method: if we rewrite this statement as  $x - 1 = 4y$ , we see that  $x - 1$  is divisible by 4, which means that  $x + 1$  is also even and the product  $n$  is divisible by 8.

The correct answer is D.

### 7.

The question stem tells us that  $z = x^{\frac{1}{2}}$ , which is simply another way of stating that  $z = \sqrt{x}$ . We are also told that  $x$ ,  $y$ , and  $z$  are positive integers and that  $x > y$ . Then we are asked whether  $x$  and  $y$  are consecutive perfect squares. For example, if  $y = 9$  and  $x = 16$ , then  $y$  and  $x$  are consecutive perfect squares. In order for  $x$  and  $y$  to be consecutive perfect squares, given that  $x$  is greater than  $y$ , it would have to be true that  $\sqrt{x} = \sqrt{y} + 1$ . For example,  $\sqrt{16} = \sqrt{9} + 1$ . [Another way of thinking about this: If  $y$  is the square of 3, then  $x$  must be the square of 4, or the square of  $(3 + 1)$ .]

Statement (1) says that  $x + y = 8z + 1$ . Using the fact that  $z = \sqrt{x}$ , we get  $z^2 = x$ . We can substitute for  $x$  into the given equation as follows:  $z^2 + y = 8z + 1$ . We can rearrange this into  $z^2 - 8z - 1 = -y$  and other similar equations. Unfortunately, these equations are not useful as no factoring is possible. So instead, let's try to prove insufficiency by picking values that demonstrate that statement (1) can go either way.

Let's begin by picking a value for  $x$ . We know that  $x$  must be a perfect square (since the square root of  $x$  is the integer  $z$ ) so it makes sense to simply start picking small perfect squares for  $x$ . If  $x$  is 4, then  $z = 2$ . Substituting these values into the equation in statement (1) yields the following:  $y = 8z + 1 - x = 8(2) + 1 - 4 = 13$ . This does not meet the constraint given in the question that  $x > y$ , so we cannot use this value for  $x$ .

If  $x$  is 9, then  $z = 3$  and  $y$  is 16. Again, this does not meet the constraint given in the question that  $x > y$  so we cannot use this value for  $x$ .

If  $x$  is 25 then  $z = 5$  and  $y$  is 16. In this case the answer to the question is YES:  $y$  and  $x$  (16 and 25) are consecutive perfect squares.

If  $x$  is 36 then  $z = 6$ , which means that  $y$  is 13. In this case the answer to the question is NO:  $y$  and  $x$  (13 and 36) are not consecutive perfect squares.

Therefore Statement (1) alone is not sufficient to answer the question.

Statement (2) says that  $x - y = 2z - 1$ . Again, using the fact that  $z = \sqrt{x}$ , we get  $z^2 = x$ . We can substitute for  $x$  into the given equation as follows:  $z^2 - y = 2z - 1$ . We can rearrange this to get  $z^2 - 2z + 1 = y$ , which we can factor into  $(z - 1)(z - 1) = y$ . Therefore,  $z - 1 = \sqrt{y}$ . We can replace  $z$  with  $\sqrt{x}$  to get  $\sqrt{x} - 1 = \sqrt{y}$ , which yields  $\sqrt{x} = \sqrt{y} + 1$ . Thus,  $x$  and  $y$  are always consecutive perfect squares. Statement (2) alone is sufficient to answer the question.

The correct answer is B: Statement (2) alone is sufficient, but statement (1) alone is not sufficient.

## Digits

1.

Solving this problem requires a bit of logic. A quick look at the ones column tells us that a value of 1 must be 'carried' to the tens column. As a result,  $p$  must equal the ones digit from the sum of  $k + 8 + 1$ , or  $k + 9$  (note that it would be incorrect to say that  $p = k + 9$ ).

Now, given that  $k$  is a non-zero digit,  $k + 9$  must be greater than or equal to 10. Furthermore, since  $k$  is a single digit and must be less than 10, we can also conclude that  $k + 9 < 20$ . Therefore, we know that a value of 1 will be 'carried' to the hundreds column as well.

We are now left with some basic algebra. In the hundreds column,  $8 + k + 1 = 16$ , so  $k = 7$ . Recall that  $p$  equals the ones digit of  $k + 9$ .  $k + 9 = 7 + 9 = 16$ , so  $p = 6$ .

The correct answer is A.

2.

There are  $3!$ , or 6, different three-digit numbers that can be constructed using the digits  $a$ ,  $b$ , and  $c$ :

$abc$	$bac$	$cab$
$acb$	$bca$	$cba$

The value of any one of these numbers can be represented using place values. For example, the value of  $abc$  is  $100a + 10b + c$ .

Therefore, you can represent the sum of the 6 numbers as:

$$\begin{array}{r} 100a + 10b + c \\ 100a + b + 10c \\ 10a + 100b + c \\ a + 100b + 10c \\ 10a + b + 100c \\ \hline a + 10b + 100c \\ \hline 222a + 222b + 222c = 222(a + b + c) \end{array}$$

$x$  is equal to  $222(a + b + c)$ . Therefore,  $x$  must be divisible by 222. The correct answer is E.

3.

If the sum of the digits of the positive two-digit number  $x$  is 4, then  $x$  must be 13, 31, 22, or 40. We can rephrase this question as "Is the value of  $x$  13, 31, 22 or 40?"

(1) INSUFFICIENT: If  $x$  is odd,  $x$  can be 13 or 31.

(2) SUFFICIENT: From the statement,  $2x < 44$ , so  $x < 22$ . This means that  $x$  must be 13.

The correct answer is B.

4.

The question asks for the value of the three-digit number  $SSS$  and tells us that  $SSS$  is the sum of the three-digit numbers  $ABC$  and  $XYZ$ . We can represent this relationship as:

$$\begin{array}{r} ABC \\ +XYZ \\ \hline SSS \end{array}$$

Statement (1) tells us that  $S = 1.75X$ . Since  $X$  is a digit between 0 and 9, inclusive,  $S$  must equal 7. This is because  $X$  must be a multiple of 4 in order for  $1.75X$  to yield an integer (remember that 1.75 is the decimal equivalent of  $7/4$ ). Therefore,  $X$  must be either 4 or 8. However,  $X$  cannot be 8 because  $1.75(8) = 14$ , which is not a digit and thus cannot be the value of  $S$ . So  $X$  must be 4 and  $1.75(4) = 7$ . Therefore, the value of  $SSS$  is 777. Statement (1) is sufficient.

Statement (2) tells us that  $S^2 = \frac{49}{8} ZX$ . If we take the square root of both sides and simplify, we get:

$$\sqrt{S^2} = \sqrt{\frac{49}{8} ZX} \rightarrow$$

$$S = 7\sqrt{\frac{ZX}{8}}$$

Since  $S$  is an integer,  $7\sqrt{\frac{ZX}{8}}$  must be an integer as well. And since  $S$  must be less than 10,  $7\sqrt{\frac{ZX}{8}}$  must

also be less than 10. The only way in the present circumstances for this to happen is if  $\sqrt{\frac{ZX}{8}} = 1$ .  
 Therefore,  $S = (7)(1) = 7$  and the value of  $SSS$  is 777. Statement (2) is sufficient.

The correct answer is D: Either statement alone is sufficient.

# GEOMETRY

## Part 1: Lines and Angles

1.

The angles labeled  $(2a)^\circ$  and  $(5a + 5)^\circ$  are supplementary (add up to  $180^\circ$ ) because together they form a line. We can solve for  $a$  as follows:

$$\begin{aligned}2a + (5a + 5) &= 180 \\ a &= 25\end{aligned}$$

The angles labeled  $(4b + 10)^\circ$  and  $(2b - 10)^\circ$  are supplementary (add up to  $180^\circ$ ) as well. We can solve for  $b$  as follows:

$$\begin{aligned}(4b + 10) + (2b - 10) &= 180 \\ b &= 30\end{aligned}$$

Now that we know both  $a$  and  $b$ , we can find  $a + b$ :

$$a + b = 25 + 30 = 55.$$

Alternatively, you could solve this problem by using the fact that opposite angles are equal, which implies that

$$5a + 5 = 4b + 10, \text{ and } 2a = 2b - 10$$

It is possible to solve this system of two equations for  $a$  and  $b$ , though the algebra required is slightly more difficult than what we used earlier to find that  $a + b = 55$ .

The correct answer is C.

2.

Because  $l_1$  is parallel to  $l_2$ , the transversal that intersects these lines forms eight angles with related measurements. All of the acute angles are equal to one another, and all of the obtuse angles are equal to one another. Furthermore, each acute angle is the supplement of each obtuse angle (i.e., they add up to  $180^\circ$ ).

Therefore,  $2x + 4y = 180$ .

Dividing both sides of the equation by 2 yields:  $x + 2y = 90$ .

The correct answer is A.

3.

(1) INSUFFICIENT: We don't know any of the angle measurements.

(2) INSUFFICIENT: We don't know the relationship of  $x$  to  $y$ .

(1) AND (2) INSUFFICIENT: Because  $l_1$  is parallel to  $l_2$ , we know the relationship of the four angles at the intersection of  $l_2$  and  $B$  ( $B$  is a transversal cutting two parallel lines) and the same four angles at the intersection of  $l_1$  and  $B$ . We do not, however, know the relationship of  $y$  to those angles because we do not know if  $B$  is parallel to  $A$ .

The correct answer is E.

4.

We are given two triangles and asked to determine the degree measure of  $z$ , an angle in one of them.

The first step in this problem is to analyze the information provided in the question stem. We are told that  $x - q = s - y$ . We can rearrange this equation to yield  $x + y = s + q$ . Since  $x + y + z = 180$  and since  $q + s + r = 180$ , it must be true that  $z = r$ . We can now look at the statements.

Statement (1) tells us that  $xq + sy + sx + yq = zr$ . In order to analyze this equation, we need to rearrange it to facilitate factorization by grouping like terms:  $xq + yq + sx + sy = zr$ . Now we can factor:

$$\begin{aligned}xq + yq + sx + sy &= zr \rightarrow \\q(x + y) + s(x + y) &= zr \rightarrow \\(x + y)(q + s) &= zr\end{aligned}$$

Since  $x + y = q + s$  and  $z = r$ , we can substitute and simplify:

$$\begin{aligned}(x + y)(q + s) &= zr \rightarrow \\(x + y)(x + y) &= (z)(z) \rightarrow \\\sqrt{(x + y)^2} &= \sqrt{z^2} \rightarrow \\x + y &= z\end{aligned}$$

Is this sufficient to tell us the value of  $z$ ? Yes. Why? Consider what happens when we substitute  $z$  for  $x + y$ :

$$\begin{aligned}x + y + z &= 180 \rightarrow \\z + z &= 180 \rightarrow \\2z &= 180 \rightarrow \\z &= 90\end{aligned}$$

It is useful to remember that when the sum of two angles of a triangle is equal to the third angle, the triangle must be a right triangle. Statement (1) is sufficient.

Statement (2) tells us that  $zq - ry = rx - zs$ . In order to analyze this equation, we need to

rearrange it:

$$zq - ry = rx - zs \rightarrow$$

$$zq + zs = rx + ry \rightarrow$$

$$z(q + s) = r(x + y) \rightarrow$$

$$z = \frac{r(x + y)}{(q + s)} \rightarrow$$

$$\frac{z}{r} = \frac{x + y}{q + s}$$

Is this sufficient to tell us the value of  $z$ ? No. Why not? Even though we know the following:

$$z = r$$

$$x + y = q + s$$

$$x + y + z = 180$$

$$q + r + s = 180$$

we can find different values that will satisfy the equation we derived from statement (2):

$$\frac{90}{90} = \frac{30 + 60}{40 + 50}$$

or

$$\frac{100}{100} = \frac{40 + 40}{10 + 70}$$

These are just two examples. We could find many more. Since we cannot determine the value of  $z$ , statement (2) is insufficient.

The correct answer is A: Statement (1) alone is sufficient, but statement (2) is not.

5. The question asks us to find the degree measure of angle  $a$ . Note that  $a$  and  $e$  are equal since they are vertical angles, so it's also sufficient to find  $e$ .

Likewise, you should notice that  $e + f + g = 180$  degrees. Thus, to find  $e$ , it is sufficient to find  $f + g$ . The question can be rephrased to the following: "What is the value of  $f + g$ ?"

(1) SUFFICIENT: Statement (1) tells us that  $b + c = 287$  degrees. This information allows us to calculate  $f + g$ . More specifically:

$$b + c = 287$$

$$(b + f) + (c + g) = 180 + 180 \quad \text{Two pairs of supplementary angles.}$$

$$b + c + f + g = 360$$

$$287 + f + g = 360$$

$$f + g = 73$$

(2) INSUFFICIENT: Statement (2) tells us that  $d + e = 269$  degrees. Since  $e = a$ , this is equivalent to  $d + a = 269$ . There are many combinations of  $d$  and  $a$  that satisfy this constraint, so we cannot determine a unique value for  $a$ . The correct answer is A.

## Part 2: Triangles

1.

Because angles  $BAD$  and  $ACD$  are right angles, the figure above is composed of three *similar* right triangles:  $BAD$ ,  $ACD$  and  $BCA$ . [Any time a height is dropped from the right angle vertex of a right triangle to the opposite side of that right triangle, the three triangles that result have the same 3 angle measures. This means that they are similar triangles.] To solve for the length of side  $CD$ , we can set up a proportion, based on the relationship between the similar triangles  $ACD$  and  $BCA$ :  $BC/AC = CA/CD$  or  $\frac{3}{4} = 4/CD$  or  $CD = 16/3$ . The correct answer is D.

2.

(1) INSUFFICIENT: This tells us that  $AC$  is the height of triangle  $BAD$  to base  $BD$ . This does not help us find the length of  $BD$ .

(2) INSUFFICIENT: This tells us that  $C$  is the midpoint of segment  $BD$ . This does not help us find the length of  $BD$ .

(1) AND (2) SUFFICIENT: Using statements 1 and 2, we know that  $AC$  is the perpendicular bisector of  $BD$ . This means that triangle  $BAD$  is an isosceles triangle so side  $AB$  must have a length of 5 (the same length as side  $AD$ ). We also know that angle  $BAD$  is a right angle, so side  $BD$  is the hypotenuse of right isosceles triangle  $BAD$ . If each leg of the triangle is 5, the hypotenuse (using the Pythagorean theorem) must be  $5\sqrt{2}$ .

The correct answer is C.

3.

(1) SUFFICIENT: If we know that  $ABC$  is a right angle, then triangle  $ABC$  is a right triangle and we can find the length of  $BC$  using the Pythagorean theorem. In this case, we can recognize the common triple 5, 12, 13 - so  $BC$  must have a length of 12.

(2) INSUFFICIENT: If the area of triangle  $ABC$  is 30, the height from point  $C$  to line  $AB$  must be 12 (We know that the base is 5 and area of a triangle =  $0.5 \times \text{base} \times \text{height}$ ). There are only two possibilities for such a triangle. Either angle  $CBA$  is a right angle, and  $CB$  is 12, or angle  $BAC$  is an obtuse angle and the height from point  $C$  to length  $AB$  would lie outside of the triangle. In this latter possibility, the length of segment  $BC$  would be greater than 12.

The correct answer is A.

4.

The perimeter of a triangle is equal to the sum of the three sides.

(1) INSUFFICIENT: Knowing the length of one side of the triangle is not enough to find the sum of all three sides.

(2) INSUFFICIENT: Knowing the length of one side of the triangle is not enough to find the sum of all three sides.

Together, the two statements are SUFFICIENT. Triangle  $ABC$  is an isosceles triangle which means that there are theoretically 2 possible scenarios for the lengths of the three sides of the triangle: (1)  $AB = 9$ ,  $BC = 4$  and the third side,  $AC = 9$  **OR** (2)  $AB = 9$ ,  $BC = 4$  and the third side

AC = 4.

These two scenarios lead to two different perimeters for triangle ABC, HOWEVER, upon careful observation we see that the second scenario is an IMPOSSIBILITY. A triangle with three sides of 4, 4, and 9 is not a triangle. Recall that any two sides of a triangle must sum up to be greater than the third side.  $4 + 4 < 9$  so these are not valid lengths for the side of a triangle.

Therefore the actual sides of the triangle must be AB = 9, BC = 4, and AC = 9. The perimeter is 22.

The correct answer is C.

## 5.

Let's begin by looking at the largest triangle (the border of the figure) and the first inscribed triangle, a mostly white triangle. We are told that all of the triangles in the figure are equilateral. To inscribe an equilateral triangle in another equilateral triangle, the inscribed triangle must touch the midpoints of each of the sides of the larger triangle.

Using similar triangles, we could show that each side of the inscribed equilateral triangle must be  $1/2$  that of the larger triangle. It also follows that the area of the inscribed triangle must be equal to  $1/4$  that of the larger triangle. This is true because area is comprised of two linear components, base and height, which for the inscribed triangle would each have a value of  $1/2$  the base and height of the larger triangle.

To see how this works, think of the big triangle's area as  $1/2(bh)$ ; the inscribed triangle's area would then be  $1/2(1/2b)(1/2h) = (1/8)bh$ , which is  $1/4$  of the area of the big triangle.

The mathematical proof notwithstanding, you could probably have guessed that the inscribed triangle's area is  $1/4$  that of the larger triangle by "eyeing it." On the GMAT, unless a figure is explicitly marked as "not drawn to scale," estimation can be a very valuable tool.

Thus, if we consider only the first equilateral triangle (the entire figure) and the white inscribed triangle, we can see that the figure is  $3/4$  shaded. This, however, is not the end of the story. We are told that this inscribed triangle and shading pattern continues until the smallest triangle has a side that is  $1/128$  or  $1/2^7$  that of the largest triangle.

We already established that the white second triangle (the first inscribed triangle) has a side  $1/2$  that of the largest triangle (the entire figure). The third triangle would have a side  $1/2$  that of the second triangle or  $1/4$  that of the largest. The triangle with a side  $1/2^7$  that of the largest would be the 8th triangle.

Now that we know that there are 8 triangles, how do we deal with the shading pattern? Perhaps the easiest way to deal with the pattern is to look at the triangles in pairs, a shaded triangle with its inscribed white triangle. Let's also assign a variable to the area of the whole figure,  $n$ . Looking at the first "pair" of triangles, we see  $(3/4)n$  of the total area is shaded.

The next area that we will analyze is the second pair of triangles, comprised of the 3rd (shaded) and 4th (white) triangles. Of course, this area is also  $3/4$  shaded. The total area of the third triangle is  $n/16$  or  $n/2^4$  so the area of the second "pair" is  $(3/4)(n/2^4)$ . In this way the area of the third "pair" would be  $(3/4)(n/2^8)$ , and the area of the fourth pair would be  $(3/4)(n/2^{12})$ . The sum of the area of the 4 pairs or 8 triangles is then:

$$\frac{3}{4}n + \frac{3}{4} \cdot \frac{n}{2^4} + \frac{3}{4} \cdot \frac{n}{2^8} + \frac{3}{4} \cdot \frac{n}{2^{12}}$$

which can be factored to

$$\frac{3}{4}n(1 + 2^{-4} + 2^{-8} + 2^{-12})$$

But remember that the question asks to find the fraction of the total figure that is shaded. We assigned the total figure an area of  $n$ ; if we put the above expression of the shaded area over

the total area  $n$ , the  $n$ 's cancel out and we get  $\frac{3}{4}(2^0 + 2^{-4} + 2^{-8} + 2^{-12})$

## 6.

The question stem tells us that ABCD is a rectangle, which means that triangle ABE is a right triangle.

The formula for the area of any triangle is:  $1/2$  (Base X Height).

In right triangle ABE, let's call the base AB and the height BE. Thus, we can rephrase the questions as follows: **Is  $1/2$  ( AB X BE) greater than 25?**

Let's begin by analyzing the first statement, taken by itself. Statement (1) tells us that the length of AB = 6. While this is helpful, it provides no information about the length of BE. Therefore there is no way to determine whether the area of the triangle is greater than 25 or not.

Now let's analyze the second statement, taken by itself. Statement (2) tells us that length of diagonal AE = 10. We may be tempted to conclude that, like the first statement, this does not give us the two pieces of information we need to know (that is, the lengths of AB and BE respectively). However, knowing the length of the diagonal of the right triangle actually does provide us with some very relevant information about the lengths of the base (AB) and the height (BE).

Consider this fact: Given the length of the diagonal of a right triangle, it **IS** possible to determine the maximum area of that triangle.

How? The right triangle with the largest area will be an isosceles right triangle (where both the base and height are of equal length).

If you don't quite believe this, see the end of this answer for a visual proof of this fact. (See "visual proof" below).

Therefore, given the length of diagonal AE = 10, we can determine the largest possible area of triangle ABE by making it an isosceles right triangle.

That important side ratio is  $1:1:\sqrt{2}$  where the two **1**'s represent the two legs (the base and the height) and  $\sqrt{2}$  represents the diagonal. Thus if we are to construct an isosceles right triangle with a diagonal of 10, then, using the side ratios, we can determine that each leg will

have a length of  $\frac{10}{\sqrt{2}}$ .

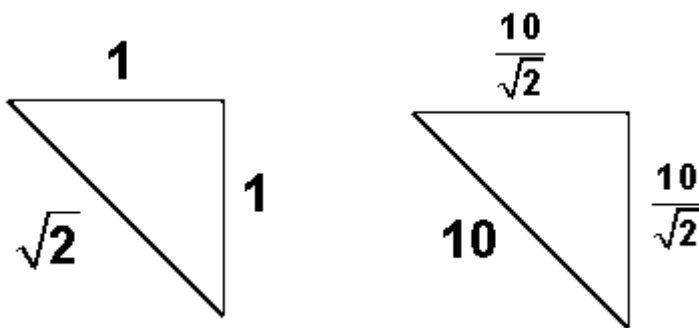

Now, we can calculate the area of this isosceles right triangle:

$$\frac{1}{2}(AB \times BE) = \frac{1}{2}\left(\frac{10}{\sqrt{2}} \times \frac{10}{\sqrt{2}}\right) = \frac{1}{2}\left(\frac{100}{2}\right) = \frac{1}{2}(50) = 25$$

Since an isosceles right triangle will yield the maximum possible area, we know that 25 is the maximum possible area of a right triangle with a diagonal of length 10.

Of course, we don't really know if 25 is, in fact, the area of triangle ABE, but we do know that 25 is the maximum possible area of triangle ABE. Therefore we are able to answer our original question: Is the area of triangle ABE greater than 25? *NO it is not greater than 25, because the maximum area is 25.*

Since we can answer the question using Statement (2) alone, the correct answer is B.

### Visual Proof:

Given a right triangle with a fixed diagonal, why will an ISOSCELES triangle yield the triangle with the greatest area?

Study the diagram below to understand why this is always true:

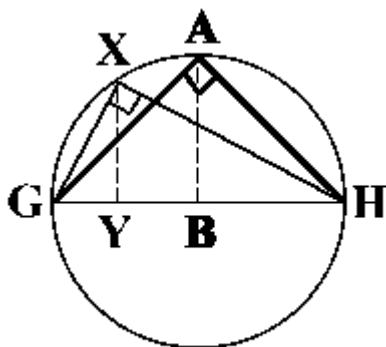

In the circle above, GH is the diameter and AG = AH. Triangles GAH and GXH are clearly both right triangles (any triangle inscribed in a semicircle is, by definition, a right triangle).

Let's begin by comparing triangles GAH and GXH, and thinking about the area of each triangle. To determine this area, we must know the base and height of each triangle.

Notice that both these right triangles share the same diagonal (GH). In determining the area of both triangles, let's use this diagonal (GH) as the base. Thus, the bases of both triangles are equal.

Now let's analyze the height of each triangle by looking at the lines that are perpendicular to our base GH. In triangle GAH, the height is line AB. In triangle GXH, the height is line XY.

Notice that the point A is HIGHER on the circle's perimeter than point X. This is because point A is directly above the center of the circle, it the highest point on the circle.

Thus, the perpendicular line extending from point A down to the base is LONGER than the perpendicular line extending from point X down to the base. Therefore, the height of triangle GAH (line AB) is greater than the height of triangle GXH (line XY).

Since both triangles share the same base, but triangle GAH has a greater height, then the area of triangle GAH must be greater than the area of triangle GXH.

*We can see that no right triangle inscribed in the circle with diameter GH will have a greater area than the isosceles right triangle GAH.*

(Note: Another way to think about this is by considering a right triangle as half of a rectangle. Given a rectangle with a fixed perimeter, which dimensions will yield the greatest area? The rectangle where all sides are equal, otherwise known as a square! Test it out for yourself. Given a rectangle with a perimeter of 40, which dimensions will yield the greatest area? The one where all four sides have a length of 10.)

## 7.

Since BC is parallel to DE, we know that Angle ABC = Angle BDE, and Angle ACB = Angle CED. Therefore, since Triangle ABC and Triangle ADE have two pairs of equal angles, they must be **similar triangles**. Similar triangles are those in which all corresponding angles are equal and the lengths of corresponding sides are in proportion.

For Triangle ABC, let the base = **b**, and let the height = **h**.

Since Triangle ADE is similar to triangle ABC, apply multiplier "**m**" to **b** and **h**. Thus, for Triangle ADE, the base = **mb** and the height = **mh**.

Since the Area of a Triangle is defined by the equation  $\frac{\text{base} \times \text{height}}{2}$ , and since the problem tells us that the area of triangle ABC is  $\frac{1}{12}$  the area of Triangle ADE, we can write an equation comparing the areas of the two triangles:

$$\frac{b \times h}{2} = \frac{1}{12} \left( \frac{mb \times mh}{2} \right)$$

Simplifying this equation yields:

$$bh = \frac{1}{12} m^2 bh$$

$$12bh = m^2 bh$$

$$12 = m^2$$

$$\sqrt{12} = m$$

$$2\sqrt{3} = m$$

Thus, we have determined that the multiplier (**m**) is  $2\sqrt{3}$ . Therefore the length of **AE** =  $2\sqrt{3} \times AC$ .

We are told in the problem that **AC** = 3, so **AE** =  $3(2\sqrt{3}) = 6\sqrt{3}$ .

The problem asks us to solve for *x*, which is the difference between the length of **AE** and the length of **AC**.

Therefore,  $x = AE - AC = 6\sqrt{3} - 3$ .

8.

By simplifying the equation given in the question stem, we can solve for *x* as follows:

$$\sqrt{x^8} = 81$$

$$x^4 = 81$$

$$x = 3$$

Thus, we know that one side of Triangle A has a length of 3.

Statement (1) tells us that Triangle A has sides whose lengths are consecutive integers. Given that one of the sides of Triangle A has a length of 3, this gives us the following possibilities: (1, 2, 3) OR (2, 3, 4) OR (3, 4, 5). However, the first possibility is NOT a real triangle, since it does not meet the following condition, which is true for all triangles: The sum of the lengths of any two sides of a triangle must always be greater than the length of the third side. Since  $1 + 2$  is not greater than 3, it is impossible for a triangle to have side lengths of 1, 2 and 3.

Thus, Statement (1) leaves us with two possibilities. Either Triangle A has side lengths 2, 3, 4 and a perimeter of 9 OR Triangle A has side lengths 3, 4, 5 and a perimeter of 12. Since there are two possible answers, Statement (1) is not sufficient to answer the question.

Statement (2) tells us that Triangle A is NOT a right triangle. On its own, this is clearly not sufficient to answer the question, since there are many non-right triangles that can be constructed with a side of length 3.

Taking both statements together, we can determine the perimeter of Triangle A. From Statement (1) we know that Triangle A must have side lengths of 2, 3, and 4 OR side lengths of 3, 4, and 5. Statement (2) tells us that Triangle A is not a right triangle; this eliminates the possibility that Triangle A has side lengths of 3, 4, and 5 since any triangle with these side lengths is a right triangle (this is one of the common Pythagorean triples). Thus, the only

remaining possibility is that Triangle A has side lengths of 2, 3, and 4, which yields a perimeter of 9.

The correct answer is C: BOTH statements TOGETHER are sufficient, but NEITHER statement ALONE is sufficient.

9.

The formula for the area of a triangle is  $1/2(bh)$ . We know the height of  $\triangle ABC$ . In order to solve for area, we need to find the length of the base. We can rephrase the question:

What is BC?

(1) INSUFFICIENT: If angle  $ABD = 60^\circ$ ,  $\triangle ABD$  must be a 30-60-90 triangle. Since the proportions of a 30-60-90 triangle are  $x : x\sqrt{3} : 2x$  (shorter leg: longer leg: hypotenuse), and  $AD = 6\sqrt{3}$ ,  $BD$  must be 6. We know nothing about  $DC$ .

(2) INSUFFICIENT: Knowing that  $AD = 6\sqrt{3}$ , and  $AC = 12$ , we can solve for  $CD$  by recognizing that  $\triangle ACD$  must be a 30-60-90 triangle (since it is a right triangle and two of its sides fit the 30-60-90 ratio), or by using the Pythagorean theorem. In either case,  $CD = 6$ , but we know nothing about  $BD$ .

(1) AND (2) SUFFICIENT: If  $BD = 6$ , and  $DC = 6$ , then  $BC = 12$ , and the area of  $\triangle ABC = 1/2(bh) = 1/2(12)(6\sqrt{3}) = 36\sqrt{3}$ .

The correct answer is C

10.

Since  $BE \parallel CD$ , triangle  $ABE$  is similar to triangle  $ACD$  (parallel lines imply two sets of equal angles). We can use this relationship to set up a ratio of the respective sides of the two triangles:

$$\frac{AB}{AC} = \frac{AE}{AD}$$

$$\frac{6}{6} = \frac{AD}{AD}$$

So  $AD = 8$ .

We can find the area of the trapezoid by finding the area of triangle  $CAD$  and subtracting the area of triangle  $ABE$ .

Triangle  $CAD$  is a right triangle since it has side lengths of 6, 8 and 10, which means that triangle  $BAE$  is also a right triangle (they share the same right angle).

$$\begin{aligned} \text{Area of trapezoid} &= \text{area of triangle } CAD - \text{area of triangle } BAE \\ &= (1/2)bh - (1/2)bh \\ &= 0.5(6)(8) - 0.5(3)(4) \\ &= 24 - 6 \\ &= 18 \end{aligned}$$

The correct answer is B

11.

According to the Pythagorean Theorem, in a right triangle  $a^2 + b^2 = c^2$ .

(1) INSUFFICIENT: With only two sides of the triangle, it is impossible to determine whether  $a^2 + b^2 = c^2$ .

(2) INSUFFICIENT: With only two sides of the triangle, it is impossible to determine whether  $a^2 + b^2 = c^2$ .

(1) AND (2) SUFFICIENT: With all three side lengths, we can determine if  $a^2 + b^2 = c^2$ . It turns out that  $17^2 + 144^2 = 145^2$ , so this is a right triangle. However, even if it were not a right triangle, this formula would still be sufficient, so it is unnecessary to finish the calculation.

The correct answer is C

12.

For triangle problems, one useful tool is the similar triangle strategy. Triangles are defined as similar if all their corresponding angles are equal or if the lengths of their corresponding sides have the same ratios.

(1) INSUFFICIENT: Just knowing that  $x = 60^\circ$  tells us nothing about triangle  $EDB$ . To illustrate, note that the exact location of point  $E$  is still unknown. Point  $E$  could be very close to the circle, making  $DE$  relatively short in length. However, point  $E$  could be quite far away from the circle, making  $DE$  relatively long in length. We cannot determine the length of  $DE$  with certainty.

(2) SUFFICIENT: If  $DE$  is parallel to  $CA$ , then  $(\text{angle } EDB) = (\text{angle } ACB) = x$ . Triangles  $EBD$  and  $ABC$  also share the angle  $ABC$ , which of course has the same measurement in each triangle. Thus, triangles  $EBD$  and  $ABC$  have two angles with identical measurements. Once you find that triangles have 2 equal angles, you know that the third angle in the two triangles must also be equal, since the sum of the angles in a triangle is  $180^\circ$ .

So, triangles  $EBD$  and  $ABC$  are similar. This means that their corresponding sides must be in proportion:

$$\begin{aligned} CB/DB &= AC/DE \\ \text{radius/diameter} &= \text{radius}/DE \\ 3.5/7 &= 3.5/DE \end{aligned}$$

Therefore,  $DE = \text{diameter} = 7$ .

The correct answer is B.

13.

First, recall that in a right triangle, the two shorter sides intersect at the right angle. Therefore, one of these sides can be viewed as the base, and the other as the height. Consequently, the area of a right triangle can be expressed as one half of the product of the two shorter sides (i.e., the same as one half of the product of the height times the base). Also, since  $AB$  is the hypotenuse of triangle  $ABC$ , we know that the two shorter sides are  $BC$  and  $AC$  and the area of triangle  $ABC = (BC \times AC)/2$ . Following the same logic, the area of triangle  $KLM = (LM \times KM)/2$ .

Also, the area of  $ABC$  is 4 times greater than the area of  $KLM$ :

$$(BC \times AC)/2 = 4(LM \times KM)/2$$

$$BC \times AC = 4(LM \times KM)$$

(1) SUFFICIENT: Since angle  $ABC$  is equal to angle  $KLM$ , and since both triangles have a right angle, we can conclude that the angles of triangle  $ABC$  are equal to the angles of triangle  $KLM$ , respectively (note that the third angle in each triangle will be equal to 35 degrees, i.e.,  $180 - 90 - 55 = 35$ ). Therefore, we can conclude that triangles  $ABC$  and  $KLM$  are similar. Consequently, the respective sides of these triangles will be proportional, i.e.  $AB/KL = BC/LM = AC/KM = x$ , where  $x$  is the coefficient of proportionality (e.g., if  $AB$  is twice as long as  $KL$ , then  $AB/KL = 2$  and for every side in triangle  $KLM$ , you could multiply that side by 2 to get the corresponding side in triangle  $ABC$ ).

We also know from the problem stem that the area of  $ABC$  is 4 times greater than the area of  $KLM$ , yielding  $BC \times AC = 4(LM \times KM)$ , as discussed above.

Knowing that  $BC/LM = AC/KM = x$ , we can solve the above expression for the coefficient of proportionality,  $x$ , by plugging in  $BC = x(LM)$  and  $AC = x(KM)$ :

$$BC \times AC = 4(LM \times KM)$$

$$x(LM) \times x(KM) = 4(LM \times KM)$$

$$x^2 = 4$$

$$x = 2 \text{ (since the coefficient of proportionality cannot be negative)}$$

Thus, we know that  $AB/KL = BC/LM = AC/KM = 2$ . Therefore,  $AB = 2KL = 2(10) = 20$

(2) INSUFFICIENT: This statement tells us the length of one of the shorter sides of the triangle  $KLM$ . We can compute all the sides of this triangle (note that this is a 6-8-10 triangle) and find its area (i.e.,  $(0.5)(6)(8) = 24$ ); finally, we can also calculate that the area of the triangle  $ABC$  is equal to 96 (four times the area of  $KLM$ ). We determined in the first paragraph of the explanation, above, that the area of  $ABC = (BC \times AC)/2$ .

Therefore:  $96 = (BC \times AC)/2$  and  $192 = BC \times AC$ . We also know the Pythagorean theorem:  $(BC)^2 + (AC)^2 = (AB)^2$ . But there is no way to convert  $BC \times AC$  into  $(BC)^2 + (AC)^2$  so we cannot determine the hypotenuse of triangle  $ABC$ .

The correct answer is A.

14.

Triangle  $DBC$  is inscribed in a semicircle (that is, the hypotenuse  $CD$  is a diameter of the circle). Therefore, angle  $DBC$  must be a right angle and triangle  $DBC$  must be a right triangle.

(1) SUFFICIENT: If the length of  $CD$  is twice that of  $BD$ , then the ratio of the length of  $BD$  to the length of the hypotenuse  $CD$  is 1 : 2. Knowing that the side ratios of a 30-60-90 triangle are 1 :  $\sqrt{3}$  : 2, where 1 represents the short leg,  $\sqrt{3}$  represents the long leg, and 2 represents the hypotenuse, we can conclude that triangle  $DBC$  is a 30-60-90 triangle. Since side  $BD$  is the short leg, angle  $x$ , the angle opposite the short leg, must be the smallest angle (30 degrees).

(2) SUFFICIENT: If triangle  $DBC$  is inscribed in a semicircle, it must be a right triangle. So, angle  $DBC$  is 90 degrees. If  $y = 60$ ,  $x = 180 - 90 - 60 = 30$ .

The correct answer is D.

15.

We are given a right triangle that is cut into four smaller right triangles. Each smaller triangle was formed by drawing a perpendicular from the right angle of a larger triangle to that larger triangle's hypotenuse. When a right triangle is divided in this way, two similar triangles are created. And each one of these smaller similar triangles is also similar to the larger triangle from which it was formed.

Thus, for example, triangle  $ABD$  is similar to triangle  $BDC$ , and both of these are similar to triangle  $ABC$ . Moreover, triangle  $BDE$  is similar to triangle  $DEC$ , and each of these is similar to triangle  $BDC$ , from which they were formed. If  $BDE$  is similar to  $BDC$  and  $BDC$  is similar to  $ABD$ , then  $BDE$  must be similar to  $ABD$  as well.

Remember that similar triangles have the same interior angles and the ratio of their side lengths are the same. So the ratio of the side lengths of  $BDE$  must be the same as the ratio of the side lengths of  $ABD$ . We are given the hypotenuse of  $BDE$ , which is also a leg of triangle  $ABD$ . If we had even one more side of  $BDE$ , we would be able to find the side lengths of  $BDE$  and thus know the ratios, which we could use to determine the sides of  $ABD$ .

(1) SUFFICIENT: If  $BE = 3$ , then  $BDE$  is a 3-4-5 right triangle.  $BDE$  and  $ABD$  are similar triangles, as discussed above, so their side measurements have the same proportion. Knowing the three side measurements of  $BDE$  and one of the side measurements of  $ABD$  is enough to allow us to calculate  $AB$ .

To illustrate:

$BD = 5$  is the hypotenuse of  $BDE$ , while  $AB$  is the hypotenuse of  $ABD$ .

The longer leg of right triangle  $BDE$  is  $DE = 4$ , and the corresponding leg in  $ABD$  is  $BD = 5$ .

Since they are similar triangles, the ratio of the longer leg to the hypotenuse should be the same in both  $BDE$  and  $ABD$ .

For  $BDE$ , the ratio of the longer leg to the hypotenuse =  $4/5$ .

For  $ABD$ , the ratio of the longer leg to the hypotenuse =  $5/AB$ .

Thus,  $4/5 = 5/AB$ , or  $AB = 25/4 = 6.25$

(2) SUFFICIENT: If  $DE = 4$ , then  $BDE$  is a 3-4-5 right triangle. This statement provides identical information to that given in statement (1) and is sufficient for the reasons given above.

The correct answer is D.

16.

The third side of a triangle must be *less* than the *sum* of the other two sides and *greater* than their difference (i.e.  $|y - z| < x < y + z$ ).

In this question:

$$|BC - AC| < AB < BC + AC$$

$$9 - 6 < AB < 9 + 6$$

$$3 < AB < 15$$

Only 13.5 is in this range.  $9\sqrt{3}$  is approximately equal to  $9(1.7)$  or 15.3.

The correct answer is C.

17. In order to find the area of the triangle, we need to find the lengths of a base and its associated height. Our strategy will be to prove that ABC is a right triangle, so that CB will be the base and AC will be its associated height.

(1) INSUFFICIENT: We now know one of the angles of triangle ABC, but this does not provide sufficient information to solve for the missing side lengths.

(2) INSUFFICIENT: Statement (2) says that the circumference of the circle is  $18\pi$ . Since the circumference of a circle equals  $\pi$  times the diameter, the diameter of the circle is 18. Therefore AB is a diameter. However, point C is still free to "slide" around the circumference of the circle giving different areas for the triangle, so this is still insufficient to solve for the area of the triangle.

(1) AND (2) SUFFICIENT: Note that inscribed triangles with one side on the diameter of the circle must be right triangles. Because the length of the diameter indicated by Statement (2) indicates that segment AB equals the diameter, triangle ABC must be a right triangle. Now, given Statement (1) we recognize that this is a 30-60-90 degree triangle. Such triangles always have side length ratios of

$$1 : \sqrt{3} : 2$$

Given a hypotenuse of 18, the other two segments AC and CB must equal 9 and  $9\sqrt{3}$  respectively. This gives us the base and height lengths needed to calculate the area of the triangle, so this is sufficient to solve the problem.

The correct answer is C.

### Topic 3: Quadrilaterals

1.

(1) INSUFFICIENT: The diagonals of a parallelogram bisect one another. Knowing that the diagonals of quadrilateral ABCD (i.e. AC and BD) bisect one another establishes that ABCD is a parallelogram, but not necessarily a rectangle.

(2) INSUFFICIENT: Having one right angle is not enough to establish a quadrilateral as a rectangle.

(1) AND (2) SUFFICIENT: According to statement (1), quadrilateral ABCD is a parallelogram. If a

parallelogram has one right angle, all of its angles are right angles (in a parallelogram opposite angles are equal and adjacent angles add up to 180), therefore the parallelogram is a rectangle. The correct answer is C.

2.

(1) SUFFICIENT: The diagonals of a rhombus are perpendicular bisectors of one another. This is in fact enough information to prove that a quadrilateral is a rhombus.

(2) SUFFICIENT: A quadrilateral with four equal sides is by definition a rhombus. The correct answer is D.

3.

(1) INSUFFICIENT: Not all rectangles are squares.

(2) INSUFFICIENT: Not every quadrilateral with two adjacent sides that are equal is a square. (For example, you can easily draw a quadrilateral with two adjacent sides of length 5, but with the third and fourth sides not being of length 5.)

(1) AND (2) SUFFICIENT:  $ABCD$  is a rectangle with two adjacent sides that are equal. This implies that all four sides of  $ABCD$  are equal, since opposite sides of a rectangle are always equal. Saying that  $ABCD$  is a rectangle with four equal sides is the same as saying that  $ABCD$  is a square.

The correct answer is C.

4.

Consider one of the diagonals of  $ABCD$ . It doesn't matter which one you pick, because the diagonals of a rectangle are equal to each other. So let's focus on  $BD$ .

$BD$  is part of triangle  $ABD$ . Since  $ABCD$  is a rectangle, we know that angle  $A$  is a right angle, so  $BD$  is the hypotenuse of right triangle  $ABD$ . Whenever a right triangle is inscribed in a circle, its hypotenuse is a diameter of that circle. Therefore,  $BD$  is a diameter of the circle  $P$ .

Knowing the length of a circle's diameter is enough to find the area of the circle. Thus, we can rephrase this question as "How long is  $BD$ ?"

(1) INSUFFICIENT: With an area of 100, rectangle  $ABCD$  could have an infinite number of diagonal lengths. The rectangle could be a square with sides 10 and 10, so that the diagonal is  $10\sqrt{2}$ . Alternatively, if the sides of the rectangle were 5 and 20, the diagonal would have a length of  $5\sqrt{17}$ .

(2) INSUFFICIENT: This does not tell us the actual length of any line in the diagram, so we don't have enough information to say how long  $BD$  is.

(1) AND (2) SUFFICIENT: If we know that  $ABCD$  is a square and we know the area of the square, we can find the diagonal of the square - in this case  $10\sqrt{2}$ .

The correct answer is C.

5. In order to find the fraction of the figure that is shaded, we need to know both the size of the shaded region (triangle  $ABD$ ) and the size of the whole trapezoid. The key to finding these areas will be finding the height of triangle  $ABD$ , which also happens to be the height of the trapezoid.

Let us draw the height of triangle  $ABD$  as a line segment from  $D$  to a point  $F$  on side  $AB$ . Because the height of any equilateral triangle divides it into two 30-60-90 triangles, we know that the

sides of triangle  $DFB$  are in the ratio 1:  $\sqrt{3}$ :2. In particular, the ratio  $DF / DB = \sqrt{3} / 2$ .

Since  $ABD$  is an equilateral triangle with  $AB = 6$ ,  $DB$  equals 6. Therefore,  $DF / 6 = \sqrt{3} / 2$ ,

which is to say that height  $DF = 3\sqrt{3}$ .

The area of triangle  $ABD = (1/2)bh = (1/2)(6)(3\sqrt{3}) = 9\sqrt{3}$

The area of trapezoid  $BACE = (1/2)(b_1 + b_2)h = (1/2)(6 + 18)(3\sqrt{3}) = 36\sqrt{3}$

The fraction of the figure that is shaded is:  $\frac{9\sqrt{3}}{36\sqrt{3}} = \frac{1}{4}$

6.

At first, it looks as if there is not enough information to solve this problem. Whenever you have a geometry problem that does not look solvable, one strategy is to look for a construction line that will add more information.

Let's draw a line from point  $E$  to point  $C$  as shown in the picture below:

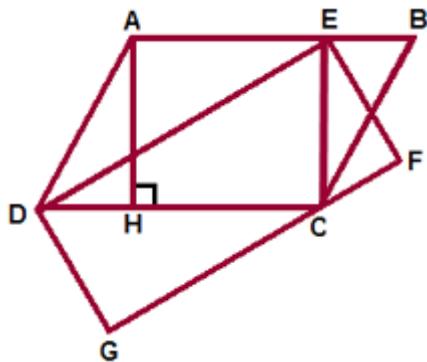

Now look at triangle  $DEC$ . Note that triangle  $DEC$  and parallelogram  $ABCD$  share the same base (line  $DC$ ). They also necessarily share the same height (the line perpendicular to base  $DC$  that passes through the point  $E$ ). Thus, the area of triangle  $DEC$  is exactly one-half that of parallelogram  $ABCD$ .

We can also look at triangle  $DEC$  another way, by thinking of line  $ED$  as its base. Notice that  $ED$  is also a side of rectangle  $DEFG$ . This means that triangle  $DEC$  is exactly one-half the area of rectangle  $DEFG$ .

We can conclude that parallelogram  $ABCD$  and  $DEFG$  have the same area!

Thus, since statement (1) gives us the area of the rectangle, it is clearly sufficient, on its own, to determine the area of the parallelogram.

Statement (2) gives us the length of line  $AH$ , the height of parallelogram  $ABCD$ . However, since

we do not know the length of either of the bases, AB or DC, we cannot determine the area of ABCD. Note also that if the length of AH is all we know, we can rescale the above figure horizontally, which would change the area of ABCD while keeping AH constant. (Think about stretching the right side of parallelogram ABCD.) Hence, statement (2) is not sufficient on its own.

The correct answer is A: Statement (1) ALONE is sufficient to answer the question, but statement (2) alone is not.

**7.**

The area of a trapezoid is equal to the average of the bases multiplied by the height. In this problem, you are given the top base ( $AB = 6$ ), but not the bottom base (CD) or the height. (Note: 8 is NOT the height!) In order to find the area, you will need a way to figure out this missing data.

Drop 2 perpendicular lines from points A and B to the horizontal base CD, and label the points at which the lines meet the base E and F, as shown.

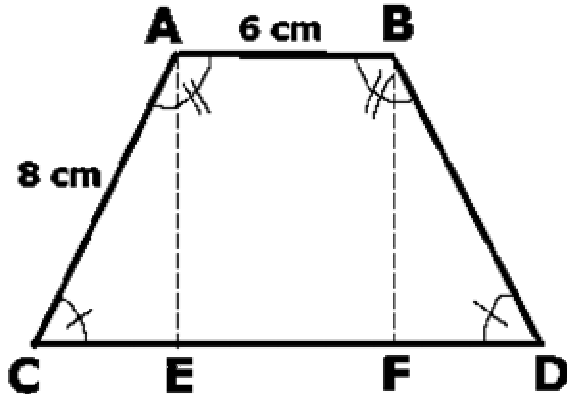

$EF = AB = 6$  cm. The congruent symbols in the drawing tell you that Angle A and Angle B are congruent, and that Angle C and Angle D are congruent. This tells you that  $AC = BD$  and  $CE = FD$ .

Statement (1) tells us that Angle A = 120. Therefore, since the sum of all 4 angles must yield 360 (which is the total number of degrees in any four-sided polygon), we know that Angle B = 120, Angle C = 60, and Angle D = 60. This means that triangle ACE and triangle BDF are both 30-60-90 triangles. The relationship among the sides of a 30-60-90 triangle is in the ratio of

$x : x\sqrt{3} : 2x$ , where  $x$  is the shortest side. For triangle ACE, since the longest side  $AC = 8$ ,  $CE = 4$  and  $AE = 4\sqrt{3}$ . The same measurements hold for triangle BFD. Thus we have the length of the bottom base ( $4 + 6 + 4$ ) and the height and we can calculate the area of the trapezoid.

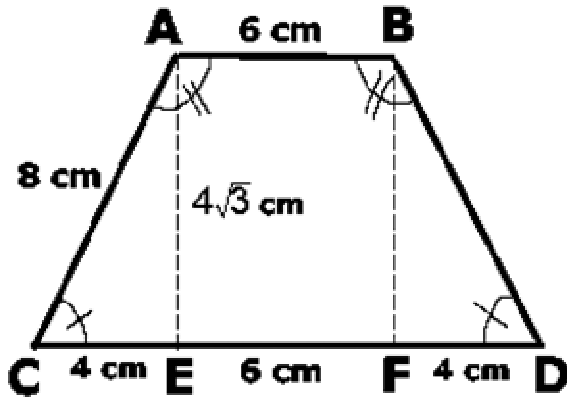

Statement (2) tells us that the perimeter of trapezoid ABCD is 36. We already know that the lengths of sides AB (6), AC (8), and BD (8) sum to 22. We can deduce that  $CD = 14$ . Further, since  $EF = 6$ , we can determine that  $CE = FD = 4$ . From this information, we can work with either Triangle ACE or Triangle BDF, and use the Pythagorean theorem to figure out the height of the trapezoid. Now, knowing the lengths of both bases, and the height, we can calculate the area of the trapezoid.

The correct answer is D: EACH statement ALONE is sufficient.

8.

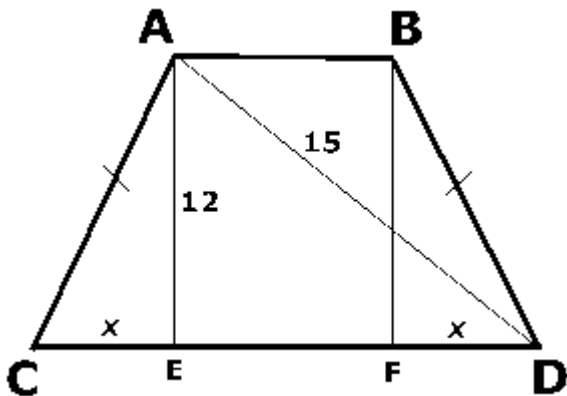

By sketching a drawing of trapezoid ABCD with the height and diagonal drawn in, we can use the Pythagorean theorem to see the  $ED = 9$ . We also know that ABCD is an isosceles trapezoid, meaning that  $AC = BD$ ; from this we can deduce that  $CE = FD$ , a value we will call  $x$ . The area of a trapezoid is equal to the average of the two bases multiplied by the height.

The bottom base, CD, is the same as  $CE + ED$ , or  $x + 9$ . The top base, AB, is the same as  $ED - FD$ , or  $9 - x$ .

$$\frac{(x+9) + (9-x)}{2} = \frac{18}{2} = 9$$

Thus the average of the two bases is

Multiplying this average by the height yields the area of the trapezoid:  $9 \times 12 = 108$ .

The correct answer is D.

9.

Assume the larger red square has a side of length  $x + 4$  units and the smaller red square has a side of length  $x - 4$  units. This satisfies the condition that the side length of the larger square is 8 more than that of the smaller square.

Therefore, the area of the larger square is  $(x + 4)^2$  or  $x^2 + 8x + 16$ . Likewise, the area of the smaller square is  $(x - 4)^2$  or  $x^2 - 8x + 16$ . Set up the following equation to represent the combined area:

$$\begin{aligned}(x^2 + 8x + 16) + (x^2 - 8x + 16) &= 1000 \\ 2x^2 + 32 &= 1000 \\ 2x^2 &= 968\end{aligned}$$

It is possible, but not necessary, to solve for the variable  $x$  here.

The two white rectangles, which are congruent to each other, are each  $x + 4$  units long and  $x - 4$  units high. Therefore, the area of either rectangle is  $(x + 4)(x - 4)$ , or  $x^2 - 16$ . Their combined area is  $2(x^2 - 16)$ , or  $2x^2 - 32$ .

Since we know that  $2x^2 = 968$ , the combined area of the two white rectangles is  $968 - 32$ , or 936 square units. The correct answer is B.

10. This question is simply asking if the two areas--the area of the circle and the area of quadrilateral ABCD--are equal.

We know that the area of a circle is equal to  $\pi r^2$ , which in this case is equal to  $\pi(XY)^2$ . If ABCD is a square or a rectangle, then its area is equal to the length times the width. Thus in order to answer this question, we will need to be given (1) the exact shape of quadrilateral ABCD (just because it appears visually to be a square or a rectangle does not mean that it is) and (2) some relationship between the radius of the circle and the side(s) of the quadrilateral that allows us to relate their respective areas.

Statement 1 appears to give us exactly what we need. Using the information given, one might deduce that since all of its sides are equal, quadrilateral ABCD is a square.

Therefore, its area is equal to one of its sides squared or  $(AB)^2$ . Substituting for the value of AB given in this statement, we can calculate that the area of ABCD equals  $(\sqrt{\pi}XY)^2 = \pi XY^2$ . This suggests that the area of quadrilateral ABCD is in fact equal to the area of the circle. However this reasoning is INCORRECT.

A common trap on difficult GMAT problems is to seduce the test-taker into making assumptions that are not verifiable; this is particularly true when unspecified figures are involved. Despite the appearance of the drawing and the fact that all sides of ABCD are equal, ABCD does not HAVE to be a square. It could, for example, also be a rhombus, which is a quadrilateral with equal sides, but one that is not necessarily composed of four right angles. The area of a rhombus is not determined by squaring a side, but rather by taking half the product of the diagonals, which do not have to be of equal length. Thus, the information in Statement 1 is NOT sufficient to determine the shape of ABCD. Therefore, it does not allow us to solve for its area and relate this area to the area of the circle.

Statement 2 tells us that the diagonals are equal--thus telling us that ABCD has right angle corners (The only way for a quadrilateral to have equal diagonals is if its corners are 90 degrees.) Statement 2 also gives us a numerical relationship between the

diagonal of ABCD and the radius of the circle. If we assume that ABCD is a square, this relationship would allow us to determine that the area of the square and the area of the circle are equal. *However, once again, we cannot assume that ABCD is a square.*

Statement 2 tells us that ABCD has 90 degree angle corners but it does not tell us that all of its sides are equal; thus, ABCD could also be a rectangle. If ABCD is a rectangle then its length is not necessarily equal to its width which means we are unable to determine its exact area (and thereby relate its area to that of the circle). Statement 2 alone is insufficient.

Given BOTH statements 1 and 2, we are assured that ABCD is a square since only squares have *both* equal sides AND equal length diagonals. Knowing that ABCD *must* be a square, we can use either numerical relationship given in the statements to confirm that the area of the quadrilateral is equal to the area of the circle. The correct answer is C: Both statements TOGETHER are sufficient, but NEITHER statement ALONE is sufficient.

11.

A parallelogram is a quadrilateral in which both pairs of opposite sides are parallel. The opposite sides of a parallelogram also have equal length.

(1) SUFFICIENT: We know from the question stem that opposite sides  $PS$  and  $QR$  are parallel, while this statement tells us that they also have equal lengths. The opposite sides  $PQ$  and  $RS$  must also be parallel and equal in length. This is the definition of a parallelogram, so the answer to the question is "Yes."

(2) INSUFFICIENT: We know from the question stem that opposite sides  $PS$  and  $QR$  are parallel, but have no information about their respective lengths. This statement tells us that the opposite sides  $PQ$  and  $RS$  are equal in length, but we don't know their respective angles; they might be parallel, or they might not be. According to the information given,  $PQRS$  could be a trapezoid with  $PS$  not equal to  $QR$ . On the other hand,  $PQRS$  could be a parallelogram with  $PS = QR$ . The answer to the question is uncertain.

The correct answer is A.

12.

To prove that a quadrilateral is a square, you must prove that it is both a rhombus (all sides are equal) and a rectangle (all angles are equal).

(1) INSUFFICIENT: Not all parallelograms are squares (however all squares are parallelograms).

(2) INSUFFICIENT: If a quadrilateral has diagonals that are perpendicular bisectors of one another, that quadrilateral is a rhombus. Not all rhombuses are squares (however all squares are rhombuses).

If we look at the two statements together, they are still insufficient. Statement (2) tells us that ABCD is a rhombus, so statement one adds no more information (all rhombuses are parallelograms). To prove that a rhombus is a square, you need to know that one of its angles is a right angle or that its diagonals are equal (i.e. that it is also a rectangle).

The correct answer is E

13. Because we do not know the type of quadrilateral, this question cannot be rephrased in a useful manner.

(1) INSUFFICIENT: We do not have enough information about the shape of the quadrilateral to solve the problem using Statement (1). For example,  $ABCD$  could be a rectangle with side lengths 3 and 5, resulting in an area of 15, or it could be a square with side length 4, resulting in an area of 16.

(2) INSUFFICIENT: This statement gives no information about the size of the quadrilateral.

(1) AND (2) SUFFICIENT: The four sides of a square are equal, so the length of one side of a square could be determined by dividing the perimeter by 4. Therefore, each side has a length of  $16/4 = 4$  and the area equals  $4(4) = 16$ .

The correct answer is C

14.

The rectangular yard has a perimeter of 40 meters (since the fence surrounds the perimeter of the yard). Let's use  $l$  for the length of the fence and  $w$  for the width.

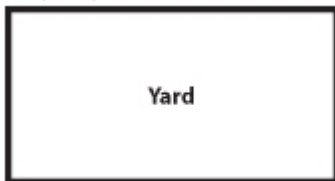

$$\begin{aligned}\text{Perimeter} &= 2l + 2w \\ 40 &= 2l + 2w \\ 20 &= l + w\end{aligned}$$

$$\begin{aligned}\text{The area of the yard} &= lw \\ 64 &= lw\end{aligned}$$

If we solve the perimeter equation for  $w$ , we get  $w = 20 - l$ .

Plug this into the area equation:

$$\begin{aligned}64 &= l(20 - l) \\ 64 &= 20l - l^2 \\ l^2 - 20l + 64 &= 0 \\ (l - 16)(l - 4) &= 0 \\ l &= 4 \text{ or } 16\end{aligned}$$

This means the width is either 16 or 4 ( $w = 20 - l$ ).

By convention, the length is the longer of the two sides so the length is 16.

We could also solve this question by backsolving the answer choices.

Let's start with C, the middle value. If the length of the yard is 12 and the perimeter is 40, the width would be 8 (perimeter  $- 2l = 2w$ ). With a length of 12 and a width of 8, the area would be 96. This is too big of an area.

It may not be intuitive whether we need the length to be longer or shorter, based on the above outcome. Consider the following geometric principle: **for a fixed perimeter, the maximum area will be achieved when the values for the length and width are closest to one**

**another.** A  $10 \times 10$  rectangle has a much bigger area than an  $18 \times 2$  rectangle. Put differently, when dealing with a fixed perimeter, the greater the disparity between the length and the width, the smaller the area.

Since we need the area to be smaller than 96, it makes sense to choose a longer length so that the disparity between the length and width will be greater.

When we get to answer choice E, we see that a length of 16 gives us a width of 4 (perimeter  $- 2l = 2w$ ). Now the area is in fact  $16 \times 4 = 64$ .

The correct answer is E

15.

If the square has an area of 9 square inches, it must have sides of 3 inches each. Therefore, sides AD and BC have lengths of 3 inches each. These sides are lengthened to  $x$  inches, while the other two remain at 3 inches. This gives us a rectangle with two opposite sides of length  $x$  and two opposite sides of length 3. Then we are asked by how much the two lengthened sides were extended. In other words, what is the value of  $x - 3$ ? In order to answer this, we need to find the value of  $x$  itself.

(1) SUFFICIENT: If the resulting rectangle has a diagonal of 5 inches, we end up with the following:

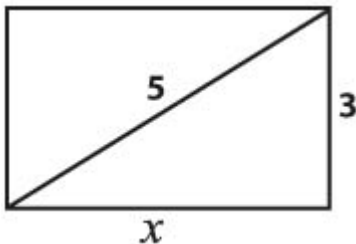

We can now see that we have a 3-4-5 right triangle, since we have a leg of 3 and a hypotenuse (the diagonal) of 5. The missing leg (in this case,  $x$ ) must equal 4. Therefore, the two sides were each extended by  $4 - 3 = 1$  inch.

(2) INSUFFICIENT: It will be possible, no matter what the value of  $x$ , to divide the resulting rectangle into three smaller rectangles of equal size. For example, if  $x = 4$ , then the area of the rectangle is 12 and we can have three rectangles with an area of 4 each. If  $x = 5$ , then the area of the rectangle is 15 and we can have three rectangles with an area of 5 each. So it is not possible to know the value of  $x$  from this statement.

The correct answer is A.

16. A rhombus is a parallelogram with four sides of equal length. Thus,  $AB = BC = CD = DA$ .

The diagonals of a parallelogram bisect each other, meaning that AC and BD intersect at their midpoints, which we will call E. Thus,  $AE = EC = 4$  and  $BE = ED = 3$ . Since ABCD is a rhombus, diagonals AC and BD are also perpendicular to each other.

Labeling the figure with the lengths above, we can see that the rhombus is divided by the diagonals into four right triangles, each of which has one side of length 3 and another side of length 4.

Remembering the common right triangle with side ratio = 3: 4: 5, we can infer that the unlabeled hypotenuse of each of the four triangles has length 5.

Thus,  $AB = BC = CD = DA = 5$ , and the perimeter of ABCD is  $5 \times 4 = 20$ .

The correct answer is C.

#### Topic 4: Circles

Let us say that line segment RT has a length of 1. RT is the radius of circle R, so circle R has a radius of 1. Line segment QT is the diameter of circle R, so it has a length of 2 (twice the radius of circle R). Segment QT also happens to be the radius of circle Q, which therefore has a radius of 2. Line segment PT, being the diameter of circle Q, has a length of 4. Segment PT also happens to be the radius of circle P, which therefore has a radius of 4. The question is asking us what fraction of circle P is shaded. The answer will be (shaded area) ÷ (area of circle P). The area of circle P is  $\pi(4)^2$ , which equals  $16\pi$ . The shaded area is just the area of circle Q (i.e.  $\pi(2)^2$ , which equals  $4\pi$ ) minus the area of circle R (i.e.  $\pi(1)^2$ , which equals  $\pi$ ). Therefore, the answer to our question is  $(4\pi - \pi) / 16\pi = 3/16$

2. Let's first consider the relationship between  $\frac{1}{a} + a$  and  $\frac{1}{a^2} + a^2$ . If we square  $\frac{1}{a} + a$ , we get:

$$\left(\frac{1}{a} + a\right)^2 \rightarrow \left(\frac{1}{a} + a\right)\left(\frac{1}{a} + a\right) \rightarrow \frac{1}{a^2} + 1 + 1 + a^2 \rightarrow \frac{1}{a^2} + a^2 + 2$$

We can use this information to manipulate the equation  $\left(\frac{1}{a} + a = 3\right)$  provided in the question. If we square both sides of the given equation, we arrive at the following:

$$\begin{aligned} \left(\frac{1}{a} + a\right) &= 3 \\ \left(\frac{1}{a} + a\right)^2 &= 3^2 \\ \frac{1}{a^2} + a^2 + 2 &= 9 \\ \frac{1}{a^2} + a^2 &= 7 \end{aligned}$$

The question asks for the approximate circumference of a circle with a diameter of  $\frac{1}{a^2} + a^2$ , which we have determined is equal to 7.

$$\text{Circumference} = \text{diameter} \times \pi = 7\pi \approx 22.$$

The correct answer is B.

3.

Consider the  $RT = D$  formula (rate  $\times$  time = distance).

$D$ , the total distance traveled by the car, will be equal to  $C$ , the circumference of each tire, times  $N$ , the number of  $360^\circ$  rotations made by each tire. Thus, we can rewrite our formula as  $RT = CN$ .

The question is asking us how many  $360^\circ$  rotations each tire makes in 10 minutes. In other words, it is asking us for the value of  $N$  when  $T = 10$ . We can rewrite our equation thus:

$$R(10) = CN$$

$$N = R(10)/C$$

Clearly, in order to answer the question "what is  $N$ " we need to know both  $R$  and  $C$ .

(1) INSUFFICIENT: This only gives us  $R$ , the speed of the car.

(2) INSUFFICIENT: This gives us the radius of the tire, which enables us to find  $C$ , the circumference of the tire. Knowing  $C$  is not, however, sufficient to figure out  $N$ .

(1) AND (2) SUFFICIENT: Now that we know both  $R$  and  $C$ , we can figure out what  $N$  is from the equation  $N = R(10)/C$ .

The correct answer is C.

4.

If we know the ratio of the radii of two circles, we know the ratio of their areas. Area is based on the square of the radius [ $A = \pi (\text{radius})^2$ ]. If the ratio of the radii of two circles is 2:1, the ratio of their areas is  $2^2:1^2$  or 4:1.

In this question, the radius of the larger circular sign is twice that of the smaller circular sign; therefore the larger sign's area is four times that of the smaller sign and would require 4 times as much paint.

The correct answer is D.

5.

First, we need the area of the smallest quarter-circle. The smallest quarter-circle will have a

radius of  $(x - 4)$  and thus an area of  $\frac{(x - 4)^2 \pi}{4}$  (we must divide by 4 because it is a quarter-circle).

Now, we need the area of the middle band. We can find this by subtracting the area of the

second quarter-circle from that of the third:  $\frac{(x - 2)^2 \pi}{4} - \frac{(x - 3)^2 \pi}{4}$ .

Now, we need the area of the outer band. We can find this by subtracting the area of the

second-largest quarter-circle from that of the largest:  $\frac{(x)^2 \pi}{4} - \frac{(x - 1)^2 \pi}{4}$ .

Finally, we need to add all these areas:

$$\begin{aligned} & \left( \frac{(x)^2 \pi}{4} - \frac{(x-1)^2 \pi}{4} \right) + \left( \frac{(x-2)^2 \pi}{4} - \frac{(x-3)^2 \pi}{4} \right) + \frac{(x-4)^2 \pi}{4} \rightarrow \\ & \frac{\pi \left( (x^2 - (x^2 - 2x + 1)) + ((x^2 - 4x + 4) - (x^2 - 6x + 9)) + x^2 - 8x + 16 \right)}{4} \rightarrow \\ & \frac{\pi (x^2 - x^2 + 2x - 1 + x^2 - 4x + 4 - x^2 + 6x - 9 + x^2 - 8x + 16)}{4} \rightarrow \\ & \frac{(x^2 - 4x + 10) \pi}{4} \end{aligned}$$

Note that we factored pi out of every term and that you must remember to distribute the minus signs as if they were -1.

## 6.

Since sector PQ is a quarter-circle, line segments QB and PB must be radii of the circle. Let  $r$  be the radius of the circle. So the question is, What is the value of  $r$ ? Since QB and PB are radii of the circle,  $QB = r$  and  $PB = r$ .

If  $AC = 100$ , and triangle ABC is a right triangle, it must be true that  $AB^2 + CB^2 = AC^2$ . We can use this to solve for  $r$ .

$CQ + QB = CB$ . Since  $CQ = 2/7QB$  and  $QB = r$ , we can construct the following equation:

$$r + \frac{2}{7}r = \frac{9}{7}r \quad \text{Therefore, } CB = \frac{9}{7}r$$

$AP + PB = AB$ . Since  $AP = 1/2PB$  and  $PB = r$ , we can construct the following equation:

$$r + \frac{1}{2}r = \frac{3}{2}r \quad \text{Therefore, } AB = \frac{3}{2}r$$

$$\text{Since } AB^2 + CB^2 = AC^2, \text{ it must be true that } \left(\frac{9}{7}r\right)^2 + \left(\frac{3}{2}r\right)^2 = 100^2$$

We can find a common denominator:

$$\left(\frac{2 \times 9}{2 \times 7}r\right)^2 + \left(\frac{7 \times 3}{7 \times 2}r\right)^2 = 100^2$$

Therefore,

$$\left(\frac{18}{14}r\right)^2 + \left(\frac{21}{14}r\right)^2 = 100^2$$

Now we can solve for  $r$ :

$$\frac{324}{196}r^2 + \frac{441}{196}r^2 = 100^2 \rightarrow$$

$$\frac{765}{196}r^2 = 100^2 \rightarrow$$

$$\sqrt{\frac{765}{196}}r^2 = \sqrt{100^2} \rightarrow$$

$$\frac{\sqrt{765}}{14}r = 100 \rightarrow$$

$$\sqrt{765}(r) = 1400 \rightarrow$$

$$r = \frac{1400}{\sqrt{765}} \rightarrow$$

$$r = \frac{1400}{\sqrt{765}} \left( \frac{\sqrt{765}}{\sqrt{765}} \right) \rightarrow$$

$$r = \frac{1400\sqrt{765}}{765} \rightarrow$$

$$r = \frac{\cancel{5}(280)\sqrt{9 \times 85}}{\cancel{5}(153)} \rightarrow$$

$$r = \frac{280 \times \cancel{3}\sqrt{85}}{\cancel{3} \times 51} \rightarrow$$

$$r = \frac{280\sqrt{85}}{51}$$

7.

Since no picture is given in the problem, draw it. Below, find the given circle with center  $P$  and cord  $XY$  bisecting radius  $AP$ .

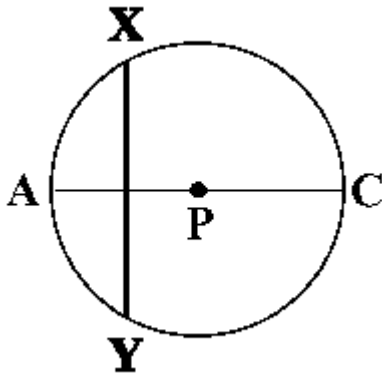

Although, the picture above is helpful, drawing in an additional radius is often an important step towards seeing the solution. Thus, we will add to the picture by drawing in radius  $XP$  as shown below.

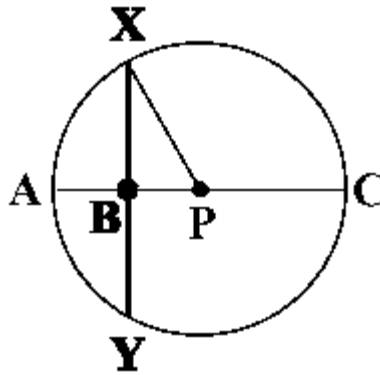

Since  $XY$  bisects radius  $AP$  at point  $B$ , segment  $BP$  is half the length of any radius.

Since  $BP$  is half the length of radius  $XP$ , right triangle  $XBP$  must be a 30-60-90 triangle with sides in the ratio of  $1 : \sqrt{3} : 2$ .

Therefore, finding the length of any side of the triangle, will give us the lengths of the other two sides.

Finding the length of radius  $XP$  will give us the length of  $XB$ , which is half the length of cord  $XY$ . Thus, in order to answer the question--**what is the length of cord  $XY$ ?**--we need to know only one piece of information:

The length of the radius of the circle.

Statement (1) alone tells us that the circumference of the circle is twice the area of the circle. Using this information, we can set up an equation and solve for the radius as follows:

$$\text{Circum} = 2 \times \text{Area}$$

$$2\pi r = 2(\pi r^2)$$

$$2r = 2r^2$$

$$r = r^2$$

$$r = 1$$

Therefore Statement (1) alone is sufficient to answer the question.

Statement (2) alone tells us that the length of Arc  $XAY = \frac{2\pi}{3}$ .

Arc  $XAY$  is made up of arc  $XA$  + arc  $AY$ .

Given that triangle  $XBP$  is a 30:60: 90 triangle, we know that  $\angle XPA = 60$  degrees and can deduce that  $\angle APY = 60$  degrees as well. Therefore Arc  $XAY = 120$  degrees or  $1/3$  of the circumference of the circle. Using this information, we can solve for the radius of the circle by setting up an equation as follows:

$$\text{Arc } XAY = \frac{1}{3} \text{ Circum}$$

$$\frac{2\pi}{3} = \frac{1}{3}(2\pi r)$$

$$2\pi = 2\pi r$$

$$1 = r$$

Therefore, Statement (2) alone is also sufficient to answer the question. The correct answer is D, each statement ALONE is sufficient.

8.

The probability of the dart landing outside the square can be expressed as follows:

$$P = \frac{\text{area of circle} - \text{area of square}}{\text{area of circle}}$$

To find the area of the circle, we need to first determine the radius. Since arc ADC has a length of  $\pi(\sqrt{x})$ , we know that the circumference of the circle must be double this length or  $2\pi(\sqrt{x})$ . Using the formula for circumference, we can solve for the radius:

$$2\pi r = 2\pi(\sqrt{x})$$

$$r = \sqrt{x}$$

$$= \pi r^2 = \pi(\sqrt{x})^2 = \pi(x)$$

Therefore, the area of the circle

To find the area of the square, we can use the fact that the diagonal of the square is equal to twice the radius of the circle. Thus, the diagonal of the square is  $2\sqrt{x}$ . Since the diagonal of the square represents the hypotenuse of a 45-45-90 triangle, we use the side ratios of this

special triangle (1:1: $\sqrt{2}$ ) to determine that each side of the square measures  $\frac{2\sqrt{x}}{\sqrt{2}} = \sqrt{2x}$ .

Thus, the area of the square  $= (\sqrt{2x})^2 = 2x$ .

Now we can calculate the total probability that the dart will land inside the circle but outside the square:

$$P = \frac{\text{area of circle} - \text{area of square}}{\text{area of circle}} = \frac{\pi(x) - 2x}{\pi(x)} = 1 - \frac{2}{\pi}$$

Interestingly, the probability does not depend on  $x$  at all, meaning that this probability holds true for any square inscribed in a circle (regardless of size).

9.

Instead of trying to find the area of the red shaded region directly by somehow measuring the area of the "cloverleaf," it is easier to find the area of the un-shaded portions and subtract that from the area of the square as a whole.

Let's call the four uncolored portions  $e$ ,  $f$ ,  $g$ , and  $h$ , respectively.

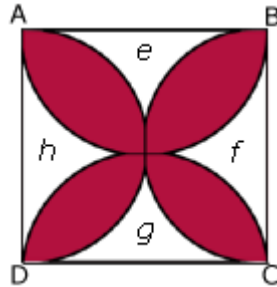

To find the combined area of  $h$  and  $f$ , we need to take the area of the square and subtract the combined area of the semicircles formed by arcs AB and DC.

To make the problem less abstract, it helps to pick a number for the variable  $x$ . Let's say each side of the square has a length of 8. Therefore, the area of the square is 64.

Since the square has a side of length 8, the diameter of each semicircle is 8, which means that

the radius is 4. So the area of each semicircle is  $\frac{\pi r^2}{2} = \frac{16\pi}{2} = 8\pi$ .

If we take the area of the square and subtract the combined area of the two semicircles formed by arcs AB and DC, we get  $64 - 2(8\pi) = 64 - 16\pi$ . This represents the combined area of  $h$  and  $f$ . The combined area of  $e$  and  $g$  is the same as that of  $h$  and  $f$ , so altogether the four uncolored portions have an area of  $2(64 - 16\pi) = 128 - 32\pi$ .

If we take the area of the square and subtract out the area of the uncolored regions, we are left with the area of the colored red region:

$$64 - (128 - 32\pi) \rightarrow 64 - 128 + 32\pi \rightarrow -64 + 32\pi \rightarrow 32\pi - 64$$

Now we need to plug in 8 for  $x$  in each answer choice. The one that produces the expression  $32\pi - 64$  is the correct answer. The only one to do so is choice (B).

(Note: One other way to think about the problem is to recognize that the combined area of the 4 semicircles (AB, AD, BC, BD) minus the area of the square is equal to the area of the red shaded region. Then one can logically proceed from this by picking a value for  $x$  in a manner similar to the procedure explained above.)

10.

One way to begin this problem is to assign the overlapping section an area of  $x$ . Therefore, the area of the non-overlapping section of circle R is equal to  $(\cdot R^2 - x)$  and the area of the non-overlapping section of circle r is equal to  $(\cdot r^2 - x)$ .

The difference in the non-overlapping areas is  $(\cdot R^2 - x) - (\cdot r^2 - x)$ . Hence, the question stem restated is: What is  $R^2 - r^2$ ?

Statement (1) states that  $R = r + 3k$ . This is equivalent to saying that  $R - r = 3k$ , but it is not sufficient to answer the question stem.

$$kR = 6 - kr$$

$$kR + kr = 6$$

$$R + r = 6/k$$

Statement (2) states that  $\frac{kR}{kr - 6} = -1$ . This can be rewritten as follows:

This is not sufficient to answer the question.

By combining statements (1) and (2) we have,  $R - r = 3k$  and  $R + r = 6/k$ .

Therefore,  $(R - r)(R + r) = R^2 - r^2 = 3k(6/k) = 18$ . This answers the restated question stem.

The correct answer is C: BOTH statements TOGETHER are sufficient, but NEITHER statement ALONE is sufficient.

11.

Triangle  $DBC$  is inscribed in a semicircle (that is, the hypotenuse  $CD$  is a diameter of the circle). Therefore, angle  $DBC$  must be a right angle and triangle  $DBC$  must be a right triangle.

(1) SUFFICIENT: If the length of  $CD$  is twice that of  $BD$ , then the ratio of the length of  $BD$  to the length of the hypotenuse  $CD$  is 1 : 2. Knowing that the side ratios of a 30-60-90 triangle are 1 :  $\sqrt{3}$  : 2, where 1 represents the short leg,  $\sqrt{3}$  represents the long leg, and 2 represents the hypotenuse, we can conclude that triangle  $DBC$  is a 30-60-90 triangle. Since side  $BD$  is the short leg, angle  $x$ , the angle opposite the short leg, must be the smallest angle (30 degrees).

(2) SUFFICIENT: If triangle  $DBC$  is inscribed in a semicircle, it must be a right triangle. So, angle  $DBC$  is 90 degrees. If  $y = 60$ ,  $x = 180 - 90 - 60 = 30$ .

The correct answer is D

12.

The radius of the small circle is 2. Calculating the area gives:

$$\text{Area} = \pi r^2$$

$$\text{Area small circle} = \pi(2)^2 = 4\pi$$

The radius of the large circle is 5. Calculating the area gives:

$$\text{Area} = \pi r^2$$

$$\text{Area large circle} = \pi(5)^2 = 25\pi$$

So, the ratio of the area of the large circle to the area of the small circle is:

$$25\pi/4\pi = 25/4$$

The correct answer is A

13.

According to the question, the ratio of the lengths of arc  $AC$  to arc  $AB$  to arc  $BC$  is 6: 2: 1. An inscribed angle cuts off an arc that is twice its measure in degrees. For example, if angle  $ACB$  is  $30^\circ$ , minor arc  $AB$  is  $60^\circ$  (or  $60/360 = 1/6$  of the circumference of the circle).

The angles of triangle  $ABC$  are all inscribed angles of the circle, so we can deduce the ratio of the angles of triangle  $ABC$  from the ratio of the lengths of minor arcs  $AC$ ,  $AB$  and  $BC$ . The ratio of the angles will be the same as the ratios of the arcs.

The ratio of angle  $ABC$  to angle  $BCA$  to angle  $BAC$  is also 6: 2: 1. Using the unknown multiplier

strategy, whereby a variable can be multiplied by each segment of a ratio to define the actual values described by that ratio, we might say that the interior angles equal  $6x: 2x: x$ . The sum of the angles in a triangle is 180, so  $x + 2x + 6x = 180$ .

$$9x = 180$$

$$x = 20$$

$$\text{Angle } BCA = 2x \text{ or } 40$$

The correct answer is B

14.

We are given a diagram of a circle with point  $O$  in the interior and points  $P$  and  $Q$  on the circle, but are not given any additional information. We are asked to find the value of the radius.

(1) INSUFFICIENT: This statement tells us the length of arc  $PQ$  but we are not told what portion of the overall circumference this represents. Although angle  $POQ$  looks like it is 90 degrees, we are not given this information and we cannot assume anything on data sufficiency; the angle could just as easily be 89 degrees. (And, in fact, we're not even told that  $O$  is in the center of the circle; if it is not, then we cannot use the degree measure to calculate anything.)

(2) INSUFFICIENT: Although we now know that  $O$  is the center of the circle, we have no information about any actual values for the circle.

(1) AND (2) INSUFFICIENT: Statement 2 corrected one of the problems we discovered while examining statement 1: we know that  $O$  is the center of the circle. However, we still do not know the measure of angle  $POQ$ . Without it, we cannot determine what portion of the overall circumference is represented by arc  $PQ$ .

The correct answer is E

15.

The circumference of the circle is  $4\sqrt{\pi\sqrt{3}}$ .

We can use this information to find the area of the circular base.

$$\text{Circumference} = 2\pi r$$

$$4\sqrt{\pi\sqrt{3}} = 2\pi r$$

$$\left(4\sqrt{\pi\sqrt{3}}\right)^2 = (2\pi r)^2$$

$$16\pi\sqrt{3} = 4\pi^2 r^2$$

$$r^2 = \frac{4\sqrt{3}}{\pi}$$

$$\text{Area} = \pi r^2$$

$$A = \pi \left( \frac{4\sqrt{3}}{\pi} \right)$$

$$A = 4\sqrt{3}$$

Because the probability of the grain of sand landing outside the triangle is  $3/4$ , the triangle must comprise  $1/4$  of the area of the circular base.

The height of an equilateral triangle splits the triangle into two 30-60-90 triangles (Each 30-60-90 triangle has sides in the ratio of  $1: \sqrt{3}: 2$ ). Because of this, the area for an equilateral triangle can be expressed in terms of one side. If we call the side of the equilateral triangle,  $s$ , the height

must be  $(s\sqrt{3}) / 2$  (using the 30-60-90 relationships).

The area of a triangle =  $1/2 \times \text{base} \times \text{height}$ , so the area of an equilateral triangle can be expressed as:  $1/2 \times s \times (s\sqrt{3}) / 2$ .

Here the triangle has an area of  $\sqrt{3}$ , so:

$$\sqrt{3} = 1/2 \times s \times (s\sqrt{3}) / 2$$
$$s = 2$$

The correct answer is E.

16.

Given that line  $CD$  is parallel to the diameter, we know that angle  $DCB$  and angle  $CBA$  are equal.

Thus  $x = 30^\circ$ .

First, let's calculate the length of arc  $CAE$ . Since arc  $CAE$  corresponds to an inscribed angle of  $60^\circ$  ( $2x = 2 \times 30^\circ = 60^\circ$ ), it must correspond to a central angle of  $120^\circ$  which is  $1/3$  of the  $360^\circ$  of the circle. Thus we can take  $1/3$  of the circumference to give us the arc length  $CAE$ . The circumference is given as  $2\pi r$ , where  $r$  is the radius. Thus the circumference equals  $10\pi$  and arc length  $CAE$  equals  $(10/3)\pi$ .

Now we need to calculate the length of  $CB$  and  $BE$ . Since they have the same angle measure, these lengths are equal so we can just find one length and double it. Let us find the length of  $CB$ . If we draw a line from  $A$  to  $C$  we have a right triangle because any inscribed triangle that includes the diameter is a right triangle. Also, we know that  $x = 30^\circ$  so we have a 30-60-90

triangle. The proportions of the length of the sides of a 30-60-90 triangle are  $1 - \sqrt{3} - 2$  for the side opposite each respective angle. We know the hypotenuse is the diameter which is  $2r = 10$ . So length  $AC$  must equal 5 and length  $CB$  must equal  $5\sqrt{3}$ .

Putting this all together gives us  $(10/3)\pi + 2 \times 5\sqrt{3} = (10/3)\pi + 10\sqrt{3}$

The correct answer is D.

## Topic 5: Polygons

1.

The formula for the sum of the interior angles of a non-convex polygon is  $(n - 2)(180)$ , where  $n$  represents the number of sides. To find the sum of the interior angles of the polygon then, we need to know the number of sides. We can therefore rephrase the question:

How many sides does the game board have?

(1) INSUFFICIENT: It tells us nothing about the number of sides. The sum of the exterior angles for *any* non-convex polygon is 360.

(2) SUFFICIENT: The sum of the exterior angles =  $5 \times \text{length of each spoke} \times \text{number of spokes}$ .

$$360 = 5(8)(x)$$

$$360 = 40x$$

$$9 = x$$

The game board has nine sides. The sum of its interior angles is  $(9 - 2)(180) = 1260$ .

The correct answer is B.

**2.**

We are told that the smallest angle measures 136 degrees--this is the first term in the consecutive set. If the polygon has  $S$  sides, then the largest angle--the last term in the consecutive set--will be  $(S - 1)$  more than 136 degrees.

The sum of consecutive integers =

$$(\text{Average Term}) \times (\# \text{ of Terms}) = \frac{\text{First} + \text{Last}}{2} \times (\# \text{ of Terms})$$

Given that there are  $S$  terms in the set, we can plug in for the first and last term as follows:

$$\frac{(136) + (136 + (S - 1))}{2} \times (S) = \text{sum of the angles in the polygon.}$$

We also know that the sum of the angles in a polygon =  $180(S - 2)$  where  $S$  represents the number of sides.

Therefore:  $180(S - 2) = \frac{(136 + 136 + (S - 1))}{2} \times (S)$ . We can solve for  $S$  by cross-multiplying and simplifying as follows:

$$2(180)(S - 2) = (272 + (S - 1)) \times S$$

$$360S - 720 = (271 + S) \times S$$

$$360S - 720 = 271S + S^2$$

$$S^2 - 89S + 720 = 0$$

A look at the answer choices tells you to try  $(S - 8)$ ,  $(S - 9)$ , or  $(S - 10)$  in factoring.

As it turns out  $(S - 9)(S - 80) = 0$ , which means  $S$  can be 9 or 80. However  $S$  cannot be 80 because this creates a polygon with angles greater than 180.

Therefore  $S$  equals 9; there are 9 sides in the polygon.

**3.**

Recall that the sum of the interior angles of a polygon is computed according to the following formula:  $180(n - 2)$ , where  $n$  represents the number of sides in the polygon. Let's use this formula to find the values of  $x$  and  $y$ :

$$x = \text{the sum of interior angles of a regular hexagon} = 180(6 - 2) = 720$$

$$y = \text{the sum of interior angles of a regular pentagon} = 180(5 - 2) = 540$$

$$x - y = 720 - 540 = 180$$

Thus, the value of  $(x - y)$ , i.e.180, is equal to the sum of interior angles of a triangle.

The correct answer is A.

4. The relationship between the number of sides in a polygon and the sum of the interior angles is given by  $180(n - 2) = (\text{sum of interior angles})$ , where  $n$  is the number of sides. Thus, if we know the sum of the interior angles, we can determine the number of sides. We can rephrase the question as follows: "What is the sum of the interior angles of Polygon  $X$ ?"

(1) SUFFICIENT: Using the relationship  $180(n - 2) = (\text{sum of interior angles})$ , we could calculate the sum of the interior angles for all the polygons that have fewer than 9 sides. Just the first two are shown below; it would take too long to calculate all of the possibilities:

polygon with 3 sides:  $180(3 - 2)$  or  $180 \times 1 = 180$

polygon with 4 sides:  $180(4 - 2)$  or  $180 \times 2 = 360$

Notice that each interior angle sum is a multiple of 180. Statement 1 tells us that the sum of the interior angles is divisible by 16. We can see from the above that each possible sum will consist of 180 multiplied by some integer.

The prime factorization of 180 is  $(2 \times 2 \times 3 \times 3 \times 5)$ . The prime factorization of 16 is  $(2 \times 2 \times 2 \times 2)$ . Therefore, two of the 2's that make up 16 can come from the 180, but the other two 2's will have to come from the integer that is multiplied by 180. Therefore, the difference  $(n - 2)$  must be a multiple of  $2 \times 2$ , or 4. Our possibilities for  $(n - 2)$  are:

3 sides:  $180(3 - 2)$  or  $180 \times 1$

4 sides:  $180(4 - 2)$  or  $180 \times 2$

5 sides:  $180(5 - 2)$  or  $180 \times 3$

6 sides:  $180(6 - 2)$  or  $180 \times 4$

7 sides:  $180(7 - 2)$  or  $180 \times 5$

8 sides:  $180(8 - 2)$  or  $180 \times 6$

Only the polygon with 6 sides has a difference  $(n - 2)$  that is a multiple of 4.

(2) INSUFFICIENT: Statement (2) tells us that the sum of the interior angles of Polygon  $X$  is divisible by 15. Therefore, the prime factorization of the sum of the interior angles will include  $3 \times 5$ . Following the same procedure as above, we realize that both 3 and 5 are included in the prime factorization of 180. As a result, every one of the possibilities can be divided by 15 regardless of the number of sides.

The correct answer is A.

5. Shaded area = Area of the hexagon – (area of circle O) – (portion of circles A, B, C, D, E, F that is in the hexagon)

With a perimeter of 36, the hexagon has a side that measures 6. The regular hexagon is comprised of six identical equilateral triangles, each with a side measuring 6. We can find the area of the hexagon by finding the area of the equilateral triangles.

The height of an equilateral triangle splits the triangle into two 30-60-90 triangles (Each 30-60-90 triangle has sides in the ratio of  $1 : \sqrt{3} : 2$ ). Because of this, the area for an

equilateral triangle can be expressed in terms of one side. If we call the side of the equilateral triangle,  $s$ , the height must be  $(s\sqrt{3})/2$  (using the 30-60-90 relationships).

The area of a triangle =  $1/2 \times \text{base} \times \text{height}$ , so the area of an equilateral triangle can be expressed as:  $1/2 \times s \times (s\sqrt{3})/2 = 1/2 \times 6 \times (3\sqrt{3}) = 9\sqrt{3}$ .

$$\text{Area of hexagon ABCDEF} = 6 \times 9\sqrt{3} = 54\sqrt{3}.$$

For circles A, B, C, D, E, and F to have centers on the vertices of the hexagon and to be tangent to one another, the circles must be the same size. Their radii must be equal to half of the side of the hexagon, 3. For circle O to be tangent to the other six circles, it too must have a radius of 3.

Area of circle O =  $\pi r^2 = 9\pi$ . To find the portion of circles A, B, C, D, E, and F that is inside the hexagon, we must consider the angles of the regular hexagon. A regular hexagon has external angles of  $360/6 = 60^\circ$ , so it has internal angles of  $180 - 60 = 120^\circ$ . This means that each circle has  $120/360$  or  $1/3$  of its area inside the hexagon.

The area of circles A, B, C, D, E, and F inside the hexagon =  $1/3(9\pi) \times 6 \text{ circles} = 18\pi$ .

Thus, the shaded area =  $54\sqrt{3} - 9\pi - 18\pi = 54\sqrt{3} - 27\pi$ . The correct answer is E.

### Topic 6: General Solids (Cube, Box, Sphere)

#### 1.

The question stem tells us that the four spheres and three cubes are arranged in order of increasing volume, with no two solids of the same type adjacent in the lineup. This allows only one possible arrangement: sphere, cube, sphere, cube, sphere, cube, sphere.

Then we are told that the ratio of one solid to the next in line is constant. This means that to find the volume of any solid after the first, one must multiply the volume of the previous solid by a constant value. If, for example, the volume of the smallest sphere were 2, the volume of the first cube (the next solid in line) would be  $2x$ , where  $x$  is the constant. The volume of the second sphere (the third solid in line) would be  $2(x)(x)$  and the volume of the second cube (the fourth solid in line) would then be  $2(x)(x)(x)$ , and so on. By the time we got to the largest sphere, the volume would be  $2x^6$ .

We are not given the value of the constant, but are told that the radius of the smallest sphere is  $1/4$  that of the largest. We can use this information to determine the value of the constant. First, if the radius of the smallest sphere is  $r$ , then the radius of the largest sphere must be  $4r$ . So if

the volume of the smallest sphere is  $\frac{4}{3}\pi r^3$ , then the volume of the largest sphere must be  $\frac{4}{3}\pi(4r)^3$  or  $\frac{4}{3}\pi 64r^3$ . So the volume of the largest sphere is 64 times larger than that of the smallest.

Using the information about the constant from the question stem, we can set up and simplify the following equation:

$$\frac{4}{3}\pi 64r^3 = \frac{4}{3}\pi r^3 x^6 \rightarrow$$

$$64 = x^6 \rightarrow$$

$$2 = x$$

Therefore, the value of the constant is 2. This means that the volume of each successive solid is twice that of the preceding solid. We are ready to look at the statements.

Statement (1) tells us that the volume of the smallest cube is  $72\pi$ . This means that the volume of the smallest sphere (the immediately preceding solid) must be half, or  $36\pi$ . If we have the volume of the smallest sphere, we can find the radius of the smallest sphere:

$$36\pi = \frac{4}{3}\pi r^3 \rightarrow$$

$$\left(\frac{3}{4}\right)36\pi = \left(\frac{3}{4}\right)\frac{4}{3}\pi r^3 \rightarrow$$

$$27\pi = \pi r^3 \rightarrow$$

$$27 = r^3 \rightarrow$$

$$3 = r$$

Therefore, the radius of the smallest sphere is 3. Statement (1) is sufficient.

Statement (2) tells us that the volume of the second largest sphere is  $576\pi$ . Applying the same logic that we used to evaluate statement (1), we can find the radius of the smallest sphere by dividing  $576\pi$  by 2 four times (because there are four solids smaller than the second largest sphere) until we get to the volume of the smallest sphere:  $36\pi$ . At this point we can solve for the radius of the smallest sphere as we did in our analysis of statement (1) above. Statement (2) is sufficient.

The correct answer is D: either statement alone is sufficient to answer the question.

2.

The diagram represents the situation described in the problem.

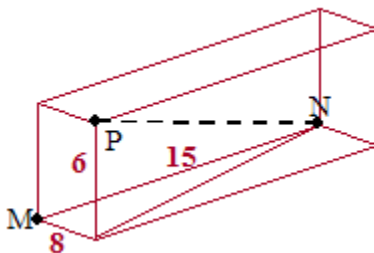

The plane (P) is at an altitude of 6 miles and is flying due north towards The Airport (M). Notice that if the plane flies in a straight line toward The Airport it would be flying along the diagonal of a right triangle with sides of length 6 and 8. Thus, taking a direct approach, the plane would fly exactly 10 miles towards The Airport (a 6-8-10 right triangle).

However, the control tower instructs the plane to fly toward a new airport (N), which lies 15 miles due east of The Airport. If the plane flies in a straight line towards the new airport, it will

be flying along the diagonal (the dotted black line) of the rectangular solid. To determine this length, we first need to determine the diagonal of the bottom face of the solid. Using the Pythagorean theorem, we can determine that the bottom face right triangle with sides of lengths 8 and 15 must have a diagonal of 17 miles (an 8-15-17 right triangle).

Now the dotted line diagonal of the solid can be calculated as follows:

$$x^2 = 6^2 + 17^2$$

$$x^2 = 325$$

$$x = 5\sqrt{13}$$

In order to arrive at the new airport at 8:00 am, the pilot's flying time must remain 3 minutes, or  $1/20$  of an hour. The flight distance, however, has increased from 10 miles to  $5\sqrt{13}$  miles. The plane's rate must increase accordingly. Using the formula that rate = distance  $\div$  time, we can calculate the rate increase as follows:

$$\text{Rate} = \frac{\text{Distance}}{\text{Time}} = \frac{(5\sqrt{13} - 10) \text{ miles}}{1/20 \text{ hr}} = 100\sqrt{13} - 200 \text{ miles/hr}$$

3.

The question asks for the ratio between a cube and a rectangular solid identical to the cube except that its length has been doubled. Since the original cube is smaller the ratio of their surface areas will be less than 1.

First let's calculate the surface area of the original cube. Since lengths were not specified, it's easiest to assign the cube a side length of 1. Each side then has a surface area of 1 square unit, and there are 6 sides giving a total surface area of 6 square units.

Now picture a rectangular solid with the length stretched out to 2 units. The two end caps will still be  $1 \times 1$  squares having a combined surface area of 2 square units. In addition, there will be 4 side rectangles each having dimensions of  $1 \times 2$ , having a combined surface area of  $4 \times 2 = 8$ . Therefore the total surface area of the rectangular solid is  $2 + 8 = 10$  square units.

The ratio will therefore be  $6/10$  which reduces to  $3/5$ .

4. The shortest distance from a vertex of the cube to the sphere would be  $1/2$  the length of the diagonal of the cube minus the radius of the sphere. To understand why, think of the parallel situation in two dimensions. In the diagram of the circle inscribed in the square to the right, the shortest possible distance from one of the vertices of the square to the circle would be  $1/2$  the diagonal of the square minus the radius of the circle.

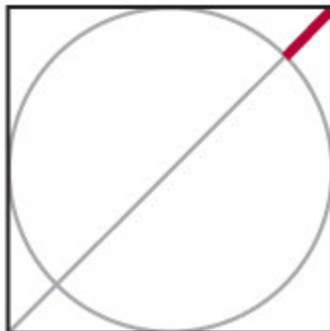

The diagonal of a cube of side  $x$  is  $x\sqrt{3}$ . This can be found by applying the Pythagorean Theorem twice (first to find the diagonal of a face of the cube,  $x\sqrt{2}$ , and then to find the diagonal through the center,  $x\sqrt{3}$ ). Like the sides of the circle in the diagram above, the sides of a sphere inscribed in a cube will touch the sides of the cube. Therefore, a sphere inscribed in a cube will have a radius equal to half the length of the side of that cube.

$$\text{Diagonal of the cube} = x\sqrt{3} = 10\sqrt{3}$$

$$\text{Radius of the sphere} = 5$$

$$\frac{1}{2} \text{ diagonal of the cube} - \text{radius of the sphere} = 5\sqrt{3} - 5 = 5(\sqrt{3} - 1)$$

The correct answer is D.

5.



Let  $x$  be the length of an edge of the cube. We can find the length of  $BC$  by first finding the length of  $CD$ .  $CD$  must be  $x\sqrt{2}$  since it is the hypotenuse of a 45-45-90 triangle with legs of length  $x$ .

Using the Pythagorean theorem,  $BC$  can be calculated:  $BC = \sqrt{x^2 + (x\sqrt{2})^2} = x\sqrt{3}$

$$AB = CD = x\sqrt{2}, \text{ so } BC - AB = x\sqrt{3} - x\sqrt{2}.$$

$$\text{If we factor this expression and simplify, } x(\sqrt{3} - \sqrt{2}) \approx x(1.7 - 1.4) \approx 0.3x.$$

Since  $BC - AB \approx 0.3x$  and  $AC = x$ , the difference between  $BC$  and  $AB$  is equal to approximately 30% of  $AC$ .

The correct answer is C.

## Topic 7: Cylinder

1.

The old volume is  $\pi R^2 H$ . Let's look at each answer choice to see which one is farthest away from twice this volume:

(A) a 100% increase to  $R$  and a 50% decrease to  $H$ :

$$\text{The new volume} = \pi (2R)^2 (.5H) = 2\pi R^2 H = \text{exactly twice the original volume.}$$

(B) a 30% decrease to  $R$  and a 300% increase to  $H$ :

The new volume =  $\pi (.7R)^2(4H) = (.49)(4) \pi R^2 H \approx 2\pi R^2 H =$  approximately twice the original volume.

(C) a 10% decrease to  $R$  and a 150% increase to  $H$ :

The new volume =  $\pi (.9R)^2(2.5H) = (.81)(2.5)\pi R^2 H \approx 2\pi R^2 H =$  approximately twice the original volume.

(D) a 40% increase to  $R$  and no change to  $H$ :

The new volume =  $\pi (1.4R)^2(H) = (1.96)\pi R^2 H \approx 2\pi R^2 H =$  approximately twice the original volume.

(E) a 50% increase to  $R$  and a 20% decrease to  $H$ :

The new volume =  $\pi (1.5R)^2(.8H) = (2.25)(.8)\pi R^2 H = 1.8\pi R^2 H$ . This is the farthest away from twice the original volume.

The correct answer is E.

2.

The surface area of a cylinder =  $2\pi r^2 + 2\pi rh$ , where  $r$  = the radius and  $h$  = the height.

Surface area of Cylinder A =  $2\pi x^2 + 2\pi xy$

Surface area of Cylinder B =  $2\pi y^2 + 2\pi xy$

Surface area of Cylinder A – surface area of Cylinder B =

$$2\pi x^2 + 2\pi xy - (2\pi y^2 + 2\pi xy) = 2\pi(x^2 - y^2)$$

3.

The surface of a right circular cylinder can be broken into three pieces as follows:

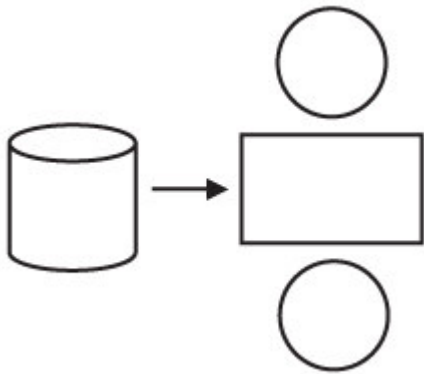

To understand why the curved side of the cylinder can be represented as a rectangle, imagine taking a sheet of 8.5x11 paper and rolling the sides forward until the edges meet in the front:

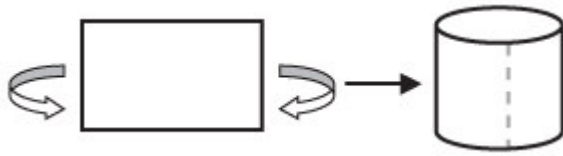

The resulting shape is the curved side of a cylinder without the top or bottom. Unrolling this side gives the rectangular surface that becomes one piece of the cylinder's surface area.

So, the total surface area can be determined by:

SA = Area of circular top + Area of rectangular side + Area of circular bottom

Inserting mathematical expressions for these areas yields

$$SA = \pi r^2 + lw + \pi r^2$$

where  $r$  is the radius of the top and bottom circles,  $l$  is the length of the rectangle and  $w$  is the width. Notice that  $l$  (in red) can be expressed as the circumference of the circle and  $w$  (dotted line) can be expressed as the height of the cylinder:

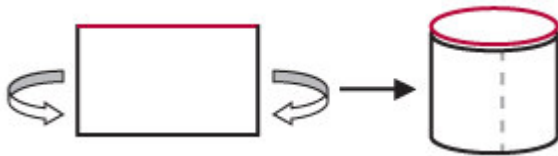

Now the equation becomes:

$$SA = \pi r^2 + 2\pi rh + \pi r^2 = 2\pi r^2 + 2\pi rh$$

Now that we have an expression for the surface area, we can begin to analyze the question. It might be tempting at this point to decide that, in order to calculate the SA, we would need to know the values of  $r$  and  $h$  explicitly. However, after some manipulation of the equation (factoring out  $2\pi r$ )...

$$SA = 2\pi r^2 + 2\pi rh$$

$$SA = 2\pi r(r + h)$$

...we can see that knowing the value of  $r(r + h)$  will be enough to determine the SA. In this case, we DON'T need to know the values of  $r$  and  $h$  explicitly. Rather, determining the value of a combination of  $r$  and  $h$  will be sufficient. So, the rephrased question becomes:

What is the value of  $r(r + h)$ ?

Statement (1),  $r = 2h - 2/h$ , cannot be manipulated to isolate  $r(r + h)$ . We can also see that different values of  $h$  we yield different surface areas. For example:

If  $h = 2$ , then  $r = 3$  and the surface area is  $30\pi$ .

But if  $h = 4$ , then  $r = 7.5$  and the surface area is  $(172.5)\pi$ .

So statement (1) does not give one and only one value for the surface area. Statement (1) is therefore NOT sufficient.

Statement (2), however can be manipulated as follows:

$$\begin{aligned}h &= 15/r - r \\ \text{(multiply through by } r) \\ hr &= 15 - r^2 \\ \text{(add } r^2 \text{ to both sides)} \\ r^2 + hr &= 15 \\ \text{(factor out an } r) \\ r(r + h) &= 15\end{aligned}$$

Statement (2) is sufficient, and the **correct answer is B**.

4.

Let's start by calculating the volume of the original cylinder.

$$\begin{aligned}V_{\text{cylinder}} &= \pi r^2 h \\ &= \pi(10)^2 10 = 1000\pi\end{aligned}$$

The new conical tank must have a volume of twice that of the cylinder, i.e.  $2000\pi$ . How does this relate to the radius and the height of the new cone?

We are given the formula for the volume of a cone  $V_{\text{cone}} = \frac{1}{3} \pi r^2 h$ .  
Let's set this equal to the known volume of the new conical tank to find an equation relating the height and radius of the new cone.

$$\begin{aligned}2000\pi &= \frac{1}{3} \pi r^2 h \\ 6000\pi &= \pi r^2 h \\ r^2 h &= 6000\end{aligned}$$

In scenario 1, the radius of the cone must remain 10, with only the height changing:

$$\begin{aligned}(10)^2 h &= 6000 \\ h &= 60\end{aligned}$$

In scenario 2, the height of the cone must remain 10, with only the radius changing:

$$\begin{aligned}r^2(10) &= 6000 \\ r^2 &= 600 \\ r &\approx 25 \quad (25^2 = 625)\end{aligned}$$

The difference between the height of the cone in scenario 1 and the radius of the cone in scenario 2 is  $60 - 25 = 35$ .

The correct answer is D.

## 5.

To solve this problem we need to (a) find the volume of the tire and then (b) solve a rate problem to determine how long it will take to inflate the tire.

To find the volume of just the tire, we can find the volume of the entire object and then subtract out the volume of the hub. In order to do this, we will first need to determine the radius of the hub.

If the radius of the hub is  $r$ , then its area equals  $\pi r^2$ .

The area of the entire object is then  $\pi(r+6)^2$ .

This means that the area of just the tire equals  $\pi(r+6)^2 - \pi r^2$ .

The problem also tells us that the ratio of the area of the tire to the area of the entire object is  $1/3$ . We can use this information to set up the following equation:

$$\frac{\text{area of hub}}{\text{area of tire}} = \frac{1}{3} = \frac{\pi r^2}{\pi(r+6)^2 - \pi r^2}$$

Now, we can solve for  $r$  as follows:

$$\begin{aligned}\frac{1}{3} &= \frac{\pi r^2}{\pi(r+6)^2 - \pi r^2} \\ \frac{1}{3} &= \frac{r^2}{(r+6)^2 - r^2} \\ 3r^2 &= (r^2 + 12r + 36) - r^2 \\ 3r^2 &= 12r + 36 \\ r^2 &= 4r + 36 \\ r^2 - 4r - 36 &= 0 \\ (r-6)(r+2) &= 0\end{aligned}$$

Thus,  $r$  is either 6 or  $-2$ . Since the radius must be positive, we know that  $r = 6$ .

To calculate volume, we simply multiply the area by a third dimension. This third dimension is the thickness of the tire (we'll call this  $h$ ), which is defined in the problem as 3 inches when the tire is fully inflated. Now, we can determine the volume of the tire using the following:

Volume of Entire Object – Volume of Hub = Volume of Tire

$$h\pi(r + 6)^2 - h\pi r^2 = \text{Volume of Tire}$$

This can be simplified as followed:

$$\begin{aligned} &= h\pi(6 + 6)^2 - h\pi 6^2 \\ &= 3\pi 12^2 - 3\pi 36 \\ &= 432\pi - 108\pi \\ &= 324\pi \end{aligned}$$

Thus, the volume of the tire is  $324\pi$  cubic inches. Using the formula  $\text{work} = \text{rate} \times \text{time}$ , we can set the volume of the tire as the total work to be done and use the rate given in the problem to determine the total time required to inflate the tire.

Work = Rate  $\times$  Time

$$\begin{aligned} 324\pi \text{in}^3 &= \frac{4\pi \text{in}^3}{\text{second}} \times t \\ t &= 81 \text{ seconds} \end{aligned}$$

The correct answer is D.

6.

The volume for a cylinder can be calculated by multiplying the area of the base times the height.

The base is a circle with an area of  $\pi r^2$ , where  $r$  is the radius of the circle. Thus the volume of a cylinder is  $\pi r^2 \times h$ , where  $h$  represents the height of the figure.

(1) SUFFICIENT: If we call the radius of the smaller cylinder  $r$ , and the height of the smaller cylinder  $h$ , the volume of the smaller cylinder would be  $\pi r^2 h$ . If the radius of the larger cylinder is twice that of the smaller one, as is the height, the volume of the larger cylinder would be  $(2r)^2(2h) = 8\pi r^2 h$ . The volume of the larger cylinder is eight times larger than that of the smaller one. If the contents of the smaller silo, which is full, are poured into the larger one, the larger one will be  $1/8$  full.

(2) INSUFFICIENT: This question is about proportions, and this statement tells us nothing about volume of the smaller silo relative to the larger one.

The correct answer is A

7.

Since water is filling the tank at a rate of 22 cubic meters per hour, after one hour there will be a "cylinder of water" in the tank (smaller than the tank itself) with a volume of 22 m<sup>3</sup>. Since the water level rises at 0.7 meters/hour, this "cylinder of water" will have a height of 0.7 meters. The radius of this "cylinder of water" will be the same as the radius of the cylindrical tank.

$$\text{Volume}_{\text{cylinder}} = \pi r^2 h$$

$$22 = \pi r^2 (0.7) \text{ (use } \pi \approx 22/7 \text{ )}$$

$$22 \approx 22/7 (7/10) r^2$$

$$r^2 \approx 10$$

$$r \approx \sqrt{10}$$

The correct answer is B.

8. One of the cylinders has a height of 6 and a base circumference of 10; the other has a height of 10 and a base circumference of 6.

The cylinder with a height of 6 and a base circumference of 10 has a radius of  $(5/\pi)$ . Its volume is equal to  $\pi r^2 h$ , or  $\pi(5/\pi)^2(6)$  or  $150/\pi$ .

The cylinder with a height of 10 and a base circumference of 6, however, has a radius of  $(3/\pi)$ . Its volume is equal to  $\pi r^2 h$ , or  $\pi(3/\pi)^2(10)$  or  $90/\pi$ .

We can see that the volume of the cylinder with a height of 6 is  $60/\pi$  inches greater than that of the cylinder with a height of 10. It makes sense in this case that the cylinder with the greater radius will have the greater volume since the radius is squared in the volume formula. The correct answer is B.

# Co-ordinate

1.  $(0+6+x)/3=3, x=3$                        $(0+0+y)/3=2, y=6$                       Answer is B

2. The two intersections:  $(0,4)$  and  $(y, 0)$                       So,  $4 * y/ 2 = 12 \Rightarrow y= 6$

Slope is positive  $\Rightarrow y$  is below the x-axis  $\Rightarrow y = -6$

3. First, let's rewrite both equations in the standard form of the equation of a line:

Equation of line  $l$ :  $y = 5x + 4$

Equation of line  $w$ :  $y = -(1/5)x - 2$

Note that the slope of line  $w$ ,  $-1/5$ , is the negative reciprocal of the slope of line  $l$ .

Therefore, we can conclude that line  $w$  is perpendicular to line  $l$ .

Next, since line  $k$  does not intersect line  $l$ , lines  $k$  and  $l$  must be parallel. Since line  $w$  is perpendicular to line  $l$ , it must also be perpendicular to line  $k$ . Therefore, lines  $k$  and  $w$  must form a right angle, and its degree measure is equal to 90 degrees.

The correct answer is D.

4. To find the distance from the origin to any point in the coordinate plane, we take the square root of the sum of the squares of the point's  $x$ - and  $y$ -coordinates. So, for example, the distance from the origin to point  $W$  is the square root of  $(a^2 + b^2)$ . This is because the distance from the origin to any point can be thought of as the hypotenuse of a right triangle with legs whose lengths have the same values as the  $x$ - and  $y$ -coordinates of the point itself:

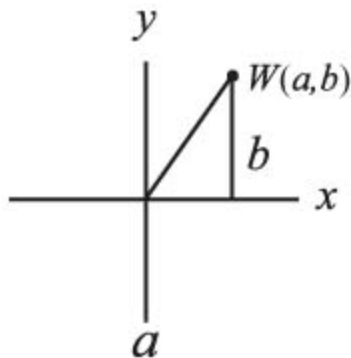

We can use the Pythagorean Theorem to determine that  $a^2 + b^2 = p^2$ , where  $p$  is the length of the hypotenuse from the origin to point  $W$ .

We are also told in the question that  $a^2 + b^2 = c^2 + d^2$ , therefore point  $X$  and point  $W$  are equidistant from the origin. And since  $e^2 + f^2 = g^2 + h^2$ , we know that point  $Y$  and point  $Z$  are also equidistant from the origin.

If the distance from the origin is the same for points  $W$  and  $X$ , and for points  $Z$  and  $Y$ , then the length of  $WY$  must be the same as the length of  $XZ$ . Therefore, the value of length  $XZ - \text{length } WY$  must be 0.

The correct answer is C.

5. The question asks us to find the slope of the line that goes through the origin and is equidistant from the two points  $P=(1, 11)$  and  $Q=(7, 7)$ . It's given that the origin is one point on the requested line, so if we can find another point known to be on the line we can calculate its slope. Incredibly the midpoint of the line segment between  $P$  and  $Q$  is also on the requested line, so all we have to do is calculate the midpoint between  $P$  and  $Q$ ! (This proof is given below).

Let's call  $R$  the midpoint of the line segment between  $P$  and  $Q$ .  $R$ 's coordinates will just be the respective average of  $P$ 's and  $Q$ 's coordinates. Therefore  $R$ 's  $x$ -coordinate equals 4, the average of 1 and 7. Its  $y$ -coordinate equals 9, the average of 11 and 7. So  $R=(4, 9)$ .

Finally, the slope from the  $(0, 0)$  to  $(4, 9)$  equals  $9/4$ , which equals 2.25 in decimal form.

### Proof

To show that the midpoint  $R$  is on the line through the origin that's equidistant from two points  $P$  and  $Q$ , draw a line segment from  $P$  to  $Q$  and mark  $R$  at its midpoint. Since  $R$  is the midpoint then  $PR = RQ$ .

Now draw a line  $L$  that goes through the origin and  $R$ . Finally draw a perpendicular from each of  $P$  and  $Q$  to the line  $L$ . The two triangles so formed are congruent, since they have three equal angles and  $PR$  equals  $RQ$ . Since the triangles are congruent their perpendicular distances to the line are equal, so line  $L$  is equidistant from  $P$  and  $Q$ .

The correct answer is B.

6. To find the slope of a line, it is helpful to manipulate the equation into slope-intercept form:  
 $y = mx + b$ , where  $m$  equals the slope of the line (incidentally,  $b$  represents the  $y$ -intercept). After isolating  $y$  on the left side of the equation, the  $x$  coefficient will tell us the slope of the line.

$$\begin{aligned}
 x + 2y &= 1 \\
 2y &= -x + 1 \\
 y &= -x/2 + 1/2
 \end{aligned}$$

The coefficient of  $x$  is  $-1/2$ , so the slope of the line is  $-1/2$ .

The correct answer is C

7. Each side of the square must have a length of 10. If each side were to be 6, 7, 8, or most other numbers, there could only be four possible squares drawn, because each side, in order to have integer coordinates, would have to be drawn on the  $x$ - or  $y$ -axis. What makes a length of 10 different is that it could be the hypotenuse of a pythagorean triple, meaning the vertices could have integer coordinates without lying on the  $x$ - or  $y$ -axis.

For example, a square could be drawn with the coordinates  $(0,0)$ ,  $(6,8)$ ,  $(-2, 14)$  and  $(-8, 6)$ . (It is tedious and unnecessary to figure out all four coordinates for each square).

If we label the square  $abcd$ , with  $a$  at the origin and the letters representing points in a clockwise direction, we can get the number of possible squares by figuring out the number of unique ways  $ab$  can be drawn.

$a$  has coordinates  $(0,0)$  and  $b$  could have coordinates:

$(-10,0)$   
 $(-8,6)$   
 $(6,8)$   
 $(0,10)$   
 $(6,8)$   
 $(8,6)$   
 $(10,0)$   
 $(8, -6)$   
 $(6, -8)$   
 $(0, 10)$   
 $(-6, -8)$   
 $(-8, -6)$

There are 12 different ways to draw  $ab$ , and so there are 12 ways to draw  $abcd$ .

The correct answer is E.

8. At the point where a curve intercepts the  $x$ -axis (i.e. the  $x$  intercept), the  $y$  value is equal to 0. If we plug  $y = 0$  in the equation of the curve, we get  $0 = (x - p)(x - q)$ . This product would only be zero when  $x$  is equal to  $p$  or  $q$ . The question is

asking us if  $(2, 0)$  is an  $x$ -intercept, so it is really asking us if either  $p$  or  $q$  is equal to 2.

(1) INSUFFICIENT: We can't find the value of  $p$  or  $q$  from this equation.

(2) INSUFFICIENT: We can't find the value of  $p$  or  $q$  from this equation.

(1) AND (2) SUFFICIENT: Together we have enough information to see if either  $p$  or  $q$  is equal to 2. To solve the two simultaneous equations, we can plug the  $p$ -value from the first equation,  $p = -8/q$ , into the second equation, to come up with  $-2 + 8/q = q$ .

This simplifies to  $q^2 + 2q - 8 = 0$ , which can be factored  $(q + 4)(q - 2) = 0$ , so  $q = 2, -4$ .

If  $q = 2, p = -4$  and if  $q = -4, p = 2$ . Either way either  $p$  or  $q$  is equal to 2.

The correct answer is C.

9. Lines are said to intersect if they share one or more points. In the graph, line segment  $QR$  connects points  $(1, 3)$  and  $(2, 2)$ . The slope of a line is the change in  $y$  divided by the change in  $x$ , or rise/run. The slope of line segment  $QR$  is  $(3 - 2)/(1 - 2) = 1/-1 = -1$ .

(1) SUFFICIENT: The equation of line  $S$  is given in  $y = mx + b$  format, where  $m$  is the slope and  $b$  is the  $y$ -intercept. The slope of line  $S$  is therefore  $-1$ , the same as the slope of line segment  $QR$ . Line  $S$  and line segment  $QR$  are parallel, so they will not intersect unless line  $S$  passes through both  $Q$  and  $R$ , and thus the entire segment. To determine whether line  $S$  passes through  $QR$ , plug the coordinates of  $Q$  and  $R$  into the equation of line  $S$ . If they satisfy the equation, then  $QR$  lies on line  $S$ .

Point  $Q$  is  $(1, 3)$ :

$$y = -x + 4 = -1 + 4 = 3$$

Point  $Q$  is on line  $S$ .

Point  $R$  is  $(2, 2)$ :

$$y = -x + 4 = -2 + 4 = 2$$

Point  $R$  is on line  $S$ .

Line segment  $QR$  lies on line  $S$ , so they share many points. Therefore, the answer is "yes," Line  $S$  intersects line segment  $QR$ .

(2) INSUFFICIENT: Line  $S$  has the same slope as line segment  $QR$ , so they are parallel. They might intersect; for example, if Line  $S$  passes through points  $Q$  and  $R$ . But they might never intersect; for example, if Line  $S$  passes above or below line segment  $QR$ .

The correct answer is A.

10. First, we determine the slope of line  $L$  as follows:

$$L = \frac{\text{rise}}{\text{run}} = \frac{\Delta y}{\Delta x} = \frac{q-3}{p-2} = \frac{2-3}{p-2} = \frac{-1}{p-2} = \frac{1}{2-p}$$

If line  $m$  is perpendicular to line  $L$ , then its slope is the negative reciprocal of line  $L$ 's slope. (This is true for all perpendicular lines.) Thus:

$$\text{If the slope of } L = \frac{a}{b}, \text{ then the slope of } m = -\frac{b}{a}.$$

Therefore, the slope of line  $m$  can be calculated using the slope of line  $L$  as follows:

$$m = -\left(\frac{1}{\frac{1}{2-p}}\right) = p-2$$

This slope can be plugged into the slope-intercept equation of a line to form the equation of line  $m$  as follows:

$$y = (p-2)x + b$$

(where  $(p-2)$  is the slope and  $b$  is the y-intercept)

This can be rewritten as  $y = px - 2x + b$  or  $2x + y = px + b$  as in answer choice A.

An alternative method: Plug in a value for  $p$ . For example, let's say that  $p = 4$ .

$$\text{Thus, the slope of line } L = \frac{\Delta y}{\Delta x} = \frac{q-3}{p-2} = \frac{2-3}{4-2} = \frac{-1}{2} = -\frac{1}{2}$$

The slope of line  $m$  is the negative inverse of the slope of line  $L$ . Thus, the slope of line  $m$  is 2.

Therefore, the correct equation for line  $m$  is the answer choice that yields a slope of 2 when the value 4 is plugged in for the variable  $p$ .

(A)  $2x + y = px + 7$  **yields**  $y = 2x + 7$

(B)  $2x + y = -px$  **yields**  $y = -6x$

(C)  $x + 2y = px + 7$  yields  $y = (3/2)x + 7/2$

(D)  $y - 7 = x \div (p - 2)$  yields  $y = (1/2)x + 7$

(E)  $2x + y = 7 - px$  yields  $y = -6x + 7$

Only answer choice A yields a slope of 2. Choice A is therefore the correct answer.

11. The distance between any two points  $(x_1, y_1)$  and  $(x_2, y_2)$  in the coordinate plane is defined by the distance formula.

$$\begin{aligned} D &= \sqrt{(x_2 - x_1)^2 + (y_2 - y_1)^2} \\ &= \sqrt{(2A + 4 - A)^2 + (\sqrt{2A + 9} - 0)^2} \\ &= \sqrt{(A + 4)^2 + (\sqrt{2A + 9} - 0)^2} \\ &= \sqrt{A^2 + 8A + 16 + 2A + 9} \\ &= \sqrt{A^2 + 10A + 25} \\ &= \sqrt{(A + 5)^2} \\ &= A + 5 \end{aligned}$$

Thus, the distance between point K and point G is  $A + 5$ .

Statement (1) tells us that:

$$\begin{aligned} A - 5A - 6 &= 0 \\ (A - 6)(A + 1) &= 0 \end{aligned}$$

Thus  $A = 6$  or  $A = -1$ .

Using this information, the distance between point K and point G is either 11 or 4. This is not sufficient to answer the question.

Statement (2) alone tells us that  $A > 2$ , which is not sufficient to answer the question.

When we combine both statements, we see that  $A$  must be 6, which means the distance between point K and point G is 11. This is a prime number and we are able to answer the question.

The correct answer is C.

12. The formula for the distance between two points  $(x_1, y_1)$  and  $(x_2, y_2)$  is:

$$\text{Distance} = \sqrt{(x_2 - x_1)^2 + (y_2 - y_1)^2}$$

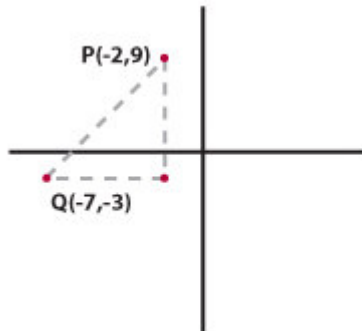

One way to understand this formula is to understand that the distance between any two points on the coordinate plane is equal to the hypotenuse of a right triangle whose legs are the difference of the  $x$ -values and the difference of the  $y$ -values (see figure). The difference of the  $x$ -values of  $P$  and  $Q$  is 5 and the difference of the  $y$ -values is 12. The hypotenuse must be 13 because these leg values are part of the known right triangle triple: 5, 12, 13.

We are told that this length (13) is equal to the height of the equilateral triangle  $XYZ$ . An equilateral triangle can be cut into two 30-60-90 triangles, where the height of the equilateral triangle is equal to the long leg of each 30-60-90 triangle. We know that the height of  $XYZ$  is 13 so the long leg of each 30-60-90 triangle is equal to 13. Using the ratio of the sides of a 30-60-90 triangle ( $1 : \sqrt{3} : 2$ ), we can determine that the length of the short leg of each 30-60-90 triangle is equal to  $13/\sqrt{3}$ . The short leg of each 30-60-90 triangle is equal to half of the base of equilateral triangle  $XYZ$ . Thus the base of  $XYZ = 2(13/\sqrt{3}) = 26/\sqrt{3}$ .

The question asks for the area of  $XYZ$ , which is equal to  $1/2 \times \text{base} \times \text{height}$ :

$$\frac{1}{2} \times \frac{26}{\sqrt{3}} \times 13 = \frac{169}{\sqrt{3}} = \frac{169(\sqrt{3})}{\sqrt{3}(\sqrt{3})} = \frac{169\sqrt{3}}{3}$$

The correct answer is A.

13. To find the area of equilateral triangle  $ABC$ , we need to find the length of one side. The area of an equilateral triangle can be found with just one side since there is a known ratio between the side and the height (using the 30: 60: 90 relationship). Alternatively, we can find the area of an equilateral triangle just knowing the length of its height.

(1) INSUFFICIENT: This does not give us the length of a side or the height of the equilateral triangle since we don't have the coordinates of point A.

(2) SUFFICIENT: Since  $C$  has an  $x$ -coordinate of 6, the height of the equilateral triangle must be 6.

The correct answer is B.

14. If we put the equation  $3x + 4y = 8$  in the slope-intercept form ( $y = mx + b$ ), we get:

$$y = (-3/4)x + 2$$

This means that  $m$  (the slope) =  $-3/4$  and  $b$  (the  $y$ -intercept) = 2.

We can graph this line by going to the point  $(0, 2)$  and going to the right 4 and down 3 to the point  $(0 + 4, 2 - 3)$  or  $(4, -1)$ .

If we connect these two points,  $(0, 2)$  and  $(4, -1)$ , we see that the line passes through quadrants I, II and IV.

The correct answer is C.

15. To determine in which quadrant the point  $(p, p - q)$  lies, we need to know the sign of  $p$  and the sign of  $p - q$ .

(1) SUFFICIENT: If  $(p, q)$  lies in quadrant IV,  $p$  is positive and  $q$  is negative.  $p - q$  must be positive because a positive number minus a negative number is always positive [e.g.  $2 - (-3) = 5$ ].

(2) SUFFICIENT: If  $(q, -p)$  lies in quadrant III,  $q$  is negative and  $p$  is positive. (This is the same information that was provided in statement 1).

The correct answer is D.

16. Point  $B$  is on line  $AC$ , two-thirds of the way between Point  $A$  and Point  $C$ . To find the coordinates of point  $B$ , it is helpful to imagine that you are a point traveling along line  $AC$ .

When you travel all the way from point  $A$  to point  $C$ , your  $x$ -coordinate changes 3 units (from  $x = 0$  to  $x = 3$ ). Two-thirds of the way there, at point  $B$ , your  $x$ -coordinate will have changed  $2/3$  of this amount, i.e. 2 units. The  $x$ -coordinate of  $B$  is therefore  $x = 0 + 2 = 2$ .

When you travel all the way from point  $A$  to point  $C$ , your  $y$ -coordinate changes 6 units (from  $y = -3$  to  $y = 3$ ). Two-thirds of the way there, at point  $B$ , your  $y$ -coordinate will have changed  $2/3$  of this amount, i.e. 4 units. The  $y$ -coordinate of  $B$  is therefore  $y = -3 + 4 = 1$ .

Thus, the coordinates of point  $B$  are  $(2,1)$ .

The correct answer is C.

17. The equation of a circle given in the form  $x^2 + y^2 = r^2$  indicates that the circle has a radius of  $r$  and that its center is at the origin  $(0,0)$  of the  $xy$ -coordinate system. Therefore, we know that the circle with the equation  $x^2 + y^2 = 25$  will have a radius of 5 and its center at  $(0,0)$ .

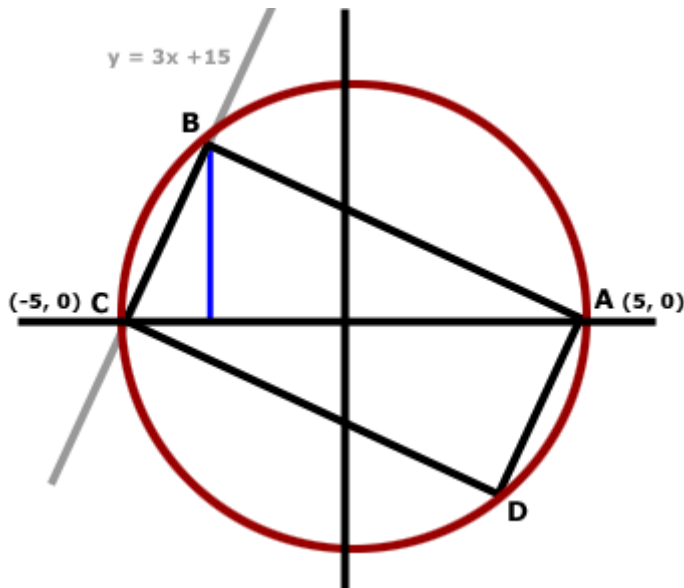

If a rectangle is inscribed in a circle, the diameter of the circle must be a diagonal of the rectangle (if you try inscribing a rectangle in a circle, you will see that it is impossible to do so unless the diagonal of the rectangle is the diameter of the circle). So diagonal  $AC$  of rectangle  $ABCD$  is the diameter of the circle and must have length 10 (remember, the radius of the circle is 5). It also cuts the rectangle into two right triangles of equal area. If we find the area of one of these triangles and multiply it by 2, we can find the area of the whole rectangle.

We could calculate the area of right triangle  $ABC$  if we had the base and height. We already know that the base of the triangle,  $AC$ , has length 10. So we need to find the height.

The height will be the distance from the  $x$ -axis to vertex  $B$ . We need to find the coordinate of point  $B$  in order to find the height. Since the circle intersects triangle  $ABCD$  at point  $B$ , the coordinates of point  $B$  will satisfy the equation of the circle  $x^2 + y^2 = 25$ . Point  $B$  also lies on the line  $y = 3x + 15$ , so the coordinates of point  $B$  will satisfy that equation as well.

Since the values of  $x$  and  $y$  are the same in both equations and since  $y = 3x + 15$ , we can substitute  $(3x + 15)$  for  $y$  in the equation  $x^2 + y^2 = 25$  and solve for  $x$ :

$$\begin{aligned}x^2 + y^2 &= 25 \rightarrow \\x^2 + (3x + 15)^2 &= 25 \rightarrow \\x^2 + (3x + 15)(3x + 15) &= 25 \rightarrow \\x^2 + 9x^2 + 90x + 225 &= 25 \rightarrow \\10x^2 + 90x + 200 &= 0 \rightarrow \\x^2 + 9x + 20 &= 0 \rightarrow \\(x + 4)(x + 5) &= 0\end{aligned}$$

So the two possible values of  $x$  are  $-4$  and  $-5$ . Therefore, the two points where the circle and line intersect (points  $B$  and  $C$ ) have  $x$ -coordinates  $-4$  and  $-5$ , respectively. Since the  $x$ -coordinate of point  $C$  is  $-5$  (it has coordinates  $(-5, 0)$ ), the  $x$ -coordinate of point  $B$  must be  $-4$ . We can plug this into the equation  $y = 3x + 15$  and solve for the  $y$ -coordinate of point  $B$ :

$$\begin{aligned}y &= 3(-4) + 15 \rightarrow \\y &= -12 + 15 \rightarrow \\y &= 3\end{aligned}$$

So the coordinates of point  $B$  are  $(-4, 3)$  and the distance from the  $x$ -axis to point  $B$  is  $3$ , making the height of triangle  $ABC$  equal to  $3$ . We can now find the area of triangle  $ABC$ :

$$\begin{aligned}\text{area of } \triangle ABC &= \frac{1}{2}(10)(3) \rightarrow \\ \text{area of } \triangle ABC &= \frac{1}{2}(30) \rightarrow \\ \text{area of } \triangle ABC &= 15\end{aligned}$$

The area of rectangle  $ABCD$  will be twice the area of triangle  $ABC$ . So if the area of triangle  $ABC$  is  $15$ , the area of rectangle  $ABCD$  is  $(2)(15) = 30$ .

The correct answer is B.

- 18.** First, rewrite the line  $y = 4 - 2x$  as  $y = -2x + 4$ . The equation is now in the form  $y = mx + b$  where  $m$  represents the slope and  $b$  represents the  $y$ -intercept. Thus, the slope of this line is  $-2$ .

By definition, if line  $F$  is the perpendicular bisector of line  $G$ , the slope of line  $F$  is the negative inverse of the slope of line  $G$ . Since we are told that the

line  $y = -2x + 4$  is the perpendicular bisector of line segment RP, line segment RP must have a slope of  $\frac{1}{2}$  (which is the negative inverse of).

Now we know that the slope of the line containing segment RP is  $\frac{1}{2}$  but we do not know its y-intercept. We can write the equation of this line as  $y = \frac{1}{2}x + b$ , where b represents the unknown y-intercept.

To solve for b, we can use the given information that the coordinates of point R are (4, 1). Since point R is on the line  $y = \frac{1}{2}x + b$ , we can plug 4 in for x and 1 in for y as follows:

$$y = \frac{1}{2}x + b$$

$$1 = \frac{1}{2}(4) + b$$

$$-1 = b$$

Now we have a complete equation for the line containing segment RP:  $y = \frac{1}{2}x - 1$

We also have the equation of the perpendicular bisector of this line:  $y = -2x + 4$ . To determine the point M at which these two lines intersect, we can set these two equations to equal each other as follows:

$$\frac{1}{2}x - 1 = -2x + 4$$

$$\frac{5}{2}x = 5$$

$$x = 2$$

Thus, the intersection point M has x-coordinate 2. Using this value, we can find the y coordinate of point M:

$$\begin{aligned} y &= -2x + 4 \\ y &= -2(2) + 4 \\ \hline y &= 0 \end{aligned}$$

Thus the perpendicular bisector intersects line segment RP at point M, which has the coordinates (2, 0). Since point M is on the bisector of RP, point M represents

the midpoint on line segment RP; this means that it is equidistant from point R and point P.

We know point R has an x-coordinate of 4. This is two units away from the x-coordinate of midpoint M, 2. Therefore the x-coordinate of point P must also be two units away from 2, which is 0.

We know point R has a y-coordinate of 1. This is one unit away from the y-coordinate of midpoint M, 0. Therefore, the y-coordinate of point P must also be one unit away from 0, which is  $-1$ .

The coordinates of point P are  $(0, -1)$ . The correct answer is D.

19.

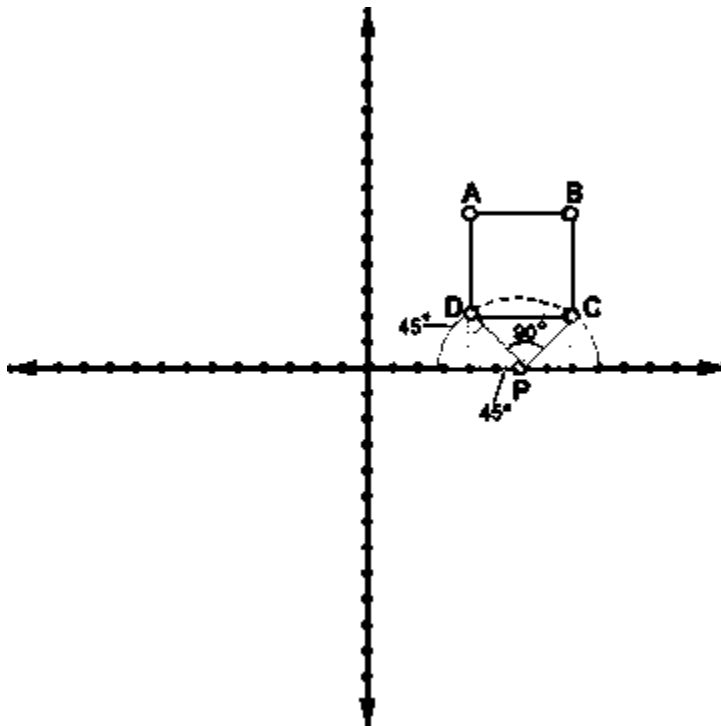

The most difficult part of this question is conceptualizing what you're asked to find. The best way to handle tricky problems like this is to break them down into their component parts, resolve each part, then reconstruct them as a whole. You start off with a coordinate plane and four points (A, B, C, and D) that form a square when joined. Beneath the square, on the x-axis, lies another point, P. Then you are asked to determine the probability that a line randomly drawn through P will not also pass through square ABCD. In any probability question, the first thing you need to determine is the number of total possibilities. In this case, the total number of possibilities will be the total number of lines that can be drawn through P. The problem, though, is that there are literally infinitely many lines

that satisfy this criterion. We cannot use infinity as the denominator of our probability fraction. So what to do?

This is where some creative thinking is necessary. First, you need to recognize that there must be a limited range of possibilities for lines that pass through both P and ABCD. If that were not the case, the probability would necessarily be 1 or 0. What is this range? Well, drawing out a diagram of the problem will help enormously here. Any line that passes through both P and ABCD has to pass through a triangle formed by ABP. This triangle is an isosceles right triangle. We know this because if we drop perpendiculars from points A and B, we end up with two isosceles right triangles, with angles of 45 degrees on either side of P. Since angles along a straight line must equal 180, we know that angle APB must measure 90 degrees. So if angle APB measures 90 degrees, we can use that to figure out the proportion of lines that pass through both P and ABCD. If we draw a semicircle with P as its center, we can see that the proportion of lines passing through P and ABCD will be the same as the proportion of the semicircle occupied by sector APB. Since a semicircle contains 180 degrees, sector APB occupies 1/2 of the semicircle. So 1/2 of all possible lines through P will also pass through ABCD, which means the 1/2 will NOT pass through ABCD and we have our answer.

The correct answer is C.

20.

Because we are given two points, we can determine the equation of the line. First, we'll calculate the slope by using the formula  $(y_2 - y_1) / (x_2 - x_1)$ :

$$\frac{[0 - (-5)]}{(7 - 0)} = \frac{-5}{7}$$

Because we know the line passes through (0,5) we have our y-intercept which is 5. Putting these two pieces of information into the slope-intercept equation gives us  $y = (-5/7)x + 5$ . Now all we have to do is plug in the x-coordinate of each of the answer choices and see which one gives us the y-coordinate.

(A) (-14, 10)

$y = -5/7(-14) + 5 = 15$ ; this does not match the given y-coordinate.

(B) (-7, 5)

$y = -5/7(-7) + 5 = 10$ ; this does not match the given y-coordinate.

(C) (12, -4)

$y = -5/7(12) + 5 = -60/7 + 5$ , which will not equal an integer; this does not match the given y-coordinate.

(D) (-14, -5)

$y = -5/7(-14) + 5 = -5$ ; this matches the given y-coordinate so we have found our answer.

(E) (21, -9)

$y = -5/7(21) + 5 = -15/7 + 5$ , which will not equal an integer; this does not match the given  $y$ -coordinate. (Note that you do not have to test this answer choice if you've already discovered that D works.)

The correct answer is D

21.

If we put the equation  $3x + 4y = 8$  in the slope-intercept form ( $y = mx + b$ ), we get:

$$y = -\frac{3}{4}x + 2, \text{ which means that } m \text{ (the slope)} = -\frac{3}{4}$$

The slope of a line perpendicular to this line must be  $\frac{4}{3}$ , the negative reciprocal of  $-\frac{3}{4}$

Among the answer choices, only E gives an equation with a slope of  $4/3$ .

The correct answer is E

22.

We are essentially asked to find the distance between two points. The simplest method is to sketch a coordinate plane and draw a right triangle using the two given points:

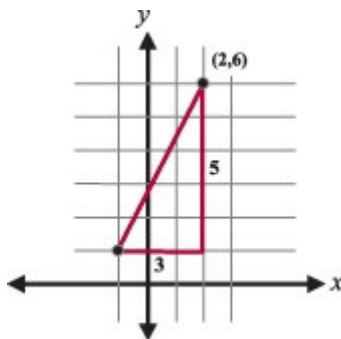

We can now see that one leg of the triangle is 3 and the other leg is 5. Because it is a right triangle, we can use the Pythagorean Theorem to calculate the hypotenuse, which is the line segment whose length we are asked to calculate.

$$3^2 + 5^2 = c^2$$

$$34 = c^2$$

$$c = \sqrt{34}$$

Note: always be careful! Some people will notice the lengths 3 and 5 and automatically assume this is a 3-4-5 right triangle. This one is *not*, however, because the hypotenuse must always be the longest side and, in this problem, the *leg* is 5 units long, not the hypotenuse.

The correct answer is C

23.

For this question it is helpful to remember that lines are perpendicular when their slopes are the negative reciprocals of each other.

(1) SUFFICIENT: Because we know the lines pass through the origin, we can figure out if the slopes are negative reciprocals of each other. The slope of  $m$  is  $-1$  so if the slope of  $n$  is  $1$  ( $-1/-1$ ) then we know the lines are perpendicular and the angle between them is  $90^\circ$ . Because we know two points for line  $n$ ,  $(0, 0)$  and  $(-a, -a)$ , we can calculate the slope:

$$\frac{0 - (-a)}{0 - (-a)} = \frac{-a}{-a} = 1$$

Thus the lines are perpendicular and the angle between them is  $90^\circ$ .

(2) SUFFICIENT: Reciprocals, when multiplied together, equal 1. Solving for one slope in terms of the other, we get  $x = -1/y$ . Thus the slopes are the negative reciprocals of each other and therefore the lines are perpendicular. Thus the angle between them must be  $90^\circ$ .

The correct answer is D

24.

Two lines are perpendicular if their slopes are opposite reciprocals. For example, the lines given by the equations  $y = 3x + 4$  and  $y = -1/3x + 7$  must be perpendicular because the slopes (3 and  $-1/3$ ) are opposite reciprocals.

The slope of a line can be found using the following equation:

$$\text{slope} = (y_2 - y_1) \div (x_2 - x_1)$$

We are given the coordinate pairs  $(3, 2)$  and  $(-1, -2)$ . The slope of the line on which these points lie is therefore  $(2 - (-2)) \div (3 - (-1)) = 4/4 = 1$ . So any line that is perpendicular to this line must have a slope of  $-1$ . Now we can check the choices for the pair that does NOT have a slope of  $-1$ .

$$(A) (8 - 9) \div (5 - 4) = -1/1 = -1.$$

$$(B) (-1 - (-2)) \div (3 - 4) = 1/(-1) = -1.$$

$$(C) (6 - 9) \div (-1 - (-4)) = -3/3 = -1.$$

$$(D) (5 - 2) \div (2 - (-3)) = 3/5.$$

$$(E) (1 - 2) \div (7 - 6) = -1/1 = -1.$$

The only pair that does not have a slope of  $-1$  is  $(2, 5)$  and  $(-3, 2)$ .

The correct answer is D

# P and C

1.  $4!, 8!/2!$
  2.  ${}^7P_4$
  3.  ${}^4P_2 + {}^4P_3 + {}^4P_4$
  4.  $4!/2!$
  5.  ${}^{10}P_2 + {}^{10}P_3$
  6.  $({}^{10}P_8 + {}^{10}P_9 + {}^{10}P_{10}) \times 12 \text{ seconds}$
  7.  $6! - 5! \times 2!$
  8.  ${}^7C_4$
  9.  ${}^{12}C_9$
  10.  ${}^2C_1 \times {}^3C_1 \times ({}^7C_4 - {}^5C_2)$
  11.  $({}^5C_3 - {}^3C_1) \times 3!$
  12.  $(4! / 2!) \times 2!$
  13.  ${}^7C_3$
  14.  ${}^7P_3$
  15.  $5! / 2!$
  16.  ${}^4P_3$
  17.  $4 \times 4 = 16$
  18. Another version:  $2 \times {}^5C_4 \times 2 = 20$
  19.  $(3! \times 2! \times 3!) \times 3!$
  20.  $3! \times 2!$
  21.  $1 \times 10 \times 10 \times 5$
  22.  ${}^5C_3 \times {}^4C_3$
  23.  $5! \times 2!$
  24.  ${}^5C_3 + {}^5C_4$
  25.  ${}^3C_2 \times 1 \times {}^3C_2$
  26.  $3! \times 2! \times 2! \times 2!$
  27. TTTTHH, HTTTHH, HHTTTH, HHHTTT; total 4
  28. The only combination of odd is  $5 \times 5 \times 5$ . So total required =  $3 \times 3 \times 3 - 1 = 26$ .
  29.  ${}^6P_4 \times 2 = 720$
  30.  $2 \times 2 \times 2 \times 4 \times 4 - 2 \times 1 \times 1 \times 4 \times 4 = 96$
  31. 10
  32.  $3! \times 3! = 36$
  33.  ${}^6C_2 \times 9 \times 3 = 405 \text{ seconds}$
  34.  $9! / 5! \times 4!$
  35.  $6 \times 2 \times 1 \times 3 \times 2 \times 1 = 72$
  36.  $(5! / 2! - 4! / 2!) = 48$ .
37. In order to answer this question, we need to be able to determine the value of  $x$ . Thus, this question can be rephrased: What is  $x$ ?
- (1) SUFFICIENT: In analyzing statement (1), consider how many individuals would have to be available to create 126 different 5 person teams. We don't actually have to figure this out as long as we know that we *could* figure this out. Certainly by testing some values, we *could* figure this out. It turns out that if there

are 9 available individuals, then we could create exactly 126 different 5-person teams (since  $9! \div [(5!)(4!)] = 126$ ). This value (9) represents  $x + 2$ . Thus  $x$  would equal 7.

(2) SUFFICIENT: The same logic applies to statement (2). Consider how many individuals would have to be available to create 56 different 3-person teams. Again, we don't actually have to figure this out as long as we know that we *could* figure this out. It turns out that if there are 8 available individuals, then we could create exactly 56 different 3-person teams (since  $8! \div [(5!)(3!)] = 56$ ). This value (8) represents  $x + 1$ . Thus  $x$  would equal 7. Statement (2) alone IS sufficient.

The correct answer is D.

38. This question is simply asking us to come up with the number of permutations that can be formed when  $x$  people are seated in  $y$  chairs. It would seem that all we require is the values of  $x$  and  $y$ . Let's keep in mind that the question stem adds that  $x$  and  $y$  must be prime integers.

(1) SUFFICIENT: If  $x$  and  $y$  are prime numbers and add up to 12,  $x$  and  $y$  must be either 7 and 5 or 5 and 7. Would the number of permutations be the same for both sets of values? Let's start with  $x = 7, y = 5$ . The number of ways to seat 7 people in 5 positions (chairs) is  $7!/2!$ . We divide by  $2!$  because 2 of the people are not selected in each seating arrangement and the order among those two people is therefore not significant. An anagram grid for this permutation would look like this:

A	B	C	D	E	F	G
1	2	3	4	5	N	N

But what if  $x = 5$  and  $y = 7$ ? How many ways are there to position five people in 7 chairs? It turns out the number of permutations is the same. One way to think of this is to consider that in addition to the five people (A,B,C,D,E), you are seating two ghosts (X,X). The number of ways to seat A,B,C,D,E,X,X would be  $7!/2!$ . We divide by  $2!$  to eliminate order from the identical X's.

Another way to look at this is by focusing on the chairs as the pool from which you are choosing. It's as if we are fixing the people in place and counting the number of ways that different chair positions can be assigned to those people. The same anagram grid as above would apply, but now the letters would correspond to the 7 chairs being assigned to each of the five fixed people. Two of the chairs would be unassigned, and thus we still divide by  $2!$  to eliminate order between those two chairs.

(2) INSUFFICIENT: This statement does not tell us anything about the values of  $x$  and  $y$ , other than  $y > x$ . The temptation in this problem is to think that you need statement 2 in conjunction with statement 1 to distinguish between the  $x = 5, y = 7$  and the  $x = 7, y = 5$  scenarios.

The correct answer is A: Statement (1) ALONE is sufficient to answer the question, but statement (2) alone is not.

39.

First, let's consider the different medal combinations that can be awarded to the 3 winners: (1) If there are NO TIES then the three medals awarded are: GOLD, SILVER, BRONZE. (2) What if there is a 2-WAY tie? --If there is a 2-WAY tie for FIRST, then the medals awarded are: GOLD, GOLD, SILVER. --If there is a 2-WAY tie for SECOND, then the medals awarded are: GOLD, SILVER, SILVER. --There cannot be a 2-WAY tie for THIRD (because exactly three medals are awarded in total). (3) What if there is a 3-WAY tie? --If there is a 3-WAY tie for FIRST, then the medals awarded are: GOLD, GOLD, GOLD. --There are no other possible 3-WAY ties. Thus, there are 4 possible medal combinations: (1) G, S, B (2) G, G, S (3) G, S, S (4) G, G, G. Now let's determine how many different ways each combination can be distributed. We'll do this by considering four runners: Albert, Bob, Cami, and Dora.

**COMBINATION 1: Gold, Silver, Bronze**

<b>Gold Medal</b>	<b>Silver Medal</b>	<b>Bronze Medal</b>
Any of the 4 runners can receive the gold medal.	There are only 3 runners who can receive the silver medal. Why? One of the runners has already been awarded the Gold Medal.	There are only 2 runners who can receive the bronze medal. Why? Two of the runners have already been awarded the Gold and Silver medals.
<b>4 possibilities</b>	<b>3 possibilities</b>	<b>2 possibilities</b>

Therefore, there are  $4 \times 3 \times 2 = 24$  different *victory circles* that will contain 1 GOLD, 1 SILVER, and 1 BRONZE medalist.

**COMBINATION 2: Gold, Gold, Silver.**

Using the same reasoning as for Combination 1, we see that there are 24 different *victory circles* that will contain 2 GOLD medalists and 1 SILVER medalist. However, it is important to realize that these 24 *victory circles* must be reduced due to "overcounting." To illustrate this, consider one of the 24 possible Gold-Gold-Silver *victory circles*: Albert is awarded a GOLD. Bob is awarded a GOLD. Cami is awarded a SILVER. Notice that this is the exact same *victory circle* as the following: Bob is awarded a GOLD. Albert is awarded a GOLD. Cami is awarded a SILVER. Each *victory circle* has been "overcounted" because we have been counting each different ordering of the two gold medals as a unique *victory circle*, when, in reality, the two different orderings consist of the exact same *victory circle*. Thus, the 24 *victory circles* must be cut in half; there are actually only **12** unique *victory circles* that will contain 2 GOLD medalists and 1 SILVER medalist. (Note that we did not have to worry about "overcounting" in Combination 1, because each of those 24 possibilities *was* unique.)

**COMBINATION 3: Gold, Silver, Silver.**

Using the same reasoning as for Combination 2, we see that there are 24 possible *victory circles*, but only **12 unique victory circles** that contain 1 GOLD medalist and 2 SILVER medalists.

**COMBINATION 4: Gold, Gold, Gold.**

Here, once again, there are 24 possible *victory circles*. However, because all three winners are gold medalists, there has been a lot of "overcounting!" How much overcounting? Let's consider one of the 24 possible Gold-Gold-Gold *victory circles*: Albert is awarded a GOLD. Bob is awarded a GOLD. Cami is awarded a GOLD. Notice that this *victory circle* is exactly the same as the following *victory circles*: Albert-GOLD, Cami-GOLD, Bob-GOLD. Bob-GOLD, Albert-GOLD, Cami-GOLD. Bob-GOLD, Cami-GOLD, Albert-GOLD. Cami-GOLD, Albert-GOLD, Bob-GOLD. Cami-GOLD, Bob-GOLD, Albert-GOLD. Each unique *victory circle* has actually been counted 6 times! Thus we must divide 24 by 6 to find the number of unique *victory circles*. There are actually only  $24 \div 6 = 4$  unique *victory circles* that contain 3 GOLD medalists. **FINALLY**, then, we have the following:

(Combination 1) 24 unique GOLD-SILVER-BRONZE *victory circles*. (Combination 2) 12 unique GOLD-GOLD-SILVER *victory circles*. (Combination 3) 12 unique GOLD-SILVER-SILVER *victory circles*. (Combination 4) 4 unique GOLD-GOLD-GOLD *victory circles*. Thus, there are  $24 + 12 + 12 + 4 = 52$  unique *victory circles*. The correct answer is **B**.

40. There are two possibilities in this problem. Either Kim and Deborah will both get chocolate chip cookies or Kim and Deborah will both get oatmeal cookies. If Kim and Deborah both get chocolate chip cookies, then there are 3 oatmeal cookies and 2 chocolate chip cookies left for the remaining four children. There are  $5!/3!2! = 10$  ways for these 5 remaining cookies to be distributed--four of the cookies will go to the children, one to the dog. (There are  $5!$  ways to arrange 5 objects but the three oatmeal cookies are identical so we divide by  $3!$ , and the two chocolate chip cookies are identical so we divide by  $2!$ .) If Kim and Deborah both get oatmeal cookies, there are 4 chocolate chip cookies and 1 oatmeal cookie left for the remaining four children. There are  $5!/4! = 5$  ways for these 5 remaining cookies to be distributed--four of the cookies will go to the children, one to the dog. (There are  $5!$  ways to arrange 5 objects but the four chocolate chip cookies are identical so we divide by  $4!$ .) Accounting for both possibilities, there are  $10 + 5 = 15$  ways for the cookies to be distributed. The correct answer is **D**.
41. In order to determine how many 10-flavor combinations Sammy can create, we simply need to know how many different flavors Sammy now has. If Sammy had  $x$  flavors to start with and then threw out  $y$  flavors, he now has  $x - y$  flavors. Therefore, we can rephrase this questions as: What is  $x - y$  ? According to statement (1), if Sammy had  $x - y - 2$  flavors, he could have made exactly 3,003

different 10-flavor bags. We could use the combination formula below to determine the value of  $x - y - 2$ , which is equal to  $n$  in the equation below:

$$\frac{n!}{10!(n-10)!} = 3,003$$

Solving this equation would require some time and more familiarity with factorials than is really necessary for the GMAT. However, keep in mind that you do not need to solve this equation; you merely need to be certain that the equation is solvable. (Note, if you begin testing values for  $n$ , you will soon find that  $n = 15$ .) Once we know the value of  $n$ , we can easily determine the value of  $x - y$ , which is simply 2 more than  $n$ . Thus, we know how many different flavors Sammy has, and could determine how many different 10-flavor combinations he could make. Statement (2) tells us that  $x = y + 17$ . Subtracting  $y$  from both sides of the equation yields the equation  $x - y = 17$ . Thus, Sammy has 17 different flavors. This information is sufficient to determine the number of different 10-flavor combinations he could make. The correct answer is D: Each statement ALONE is sufficient.

42. The three-dice combinations fall into 3 categories of outcomes:
- 1) All three dice have the same number
  - 2) Two of the dice have the same number with the third having a different number than the pair
  - 3) All three dice have different numbers
- By calculating the number of combinations in each category, we can determine the total number of different possible outcomes by summing the number of possible outcomes in each category.
- First, let's calculate how many combinations can be made if all 3 dice have the same number. Since there are only 6 numbers, there are only 6 ways for all three dice to have the same number (i.e., all 1's, or all 2's, etc.).
- Second, we can determine how many combinations can occur if only 2 of the dice have the same number. There are 6 different ways that 2 dice can be paired (i.e., two 1's, or two 2's or two 3's, etc.). For each given pair of 2 dice, the third die can be one of the five other numbers. (For example if two of the dice are 1's, then the third die must have one of the 5 other numbers: 2, 3, 4, 5, or 6.) Therefore there are  $6 \times 5 = 30$  combinations of outcomes that involve 2 dice with the same number.
- Third, determine how many combinations can occur if all three dice have different numbers. Think of choosing three of the 6 items (each of the numbers) to fill three "slots." For the first slot, we can choose from 6 possible items. For the second slot, we can choose from the 5 remaining items. For the third slot, we can choose from the 4 remaining items. Hence, there are  $6 \times 5 \times 4 = 120$  ways to fill the three slots. However, we do not care about the order of the items, so permutations like  $\{1,2,5\}$ ,  $\{5, 2, 1\}$ ,  $\{2, 5, 1\}$ ,  $\{2, 1, 5\}$ ,  $\{5, 1, 2\}$ , and  $\{1, 5, 2\}$  are all considered to be the same result. There are  $3! = 6$  ways that each group of three numbers can be ordered, so we must divide 120 by 6 in order to obtain the number of combinations where order does not matter (every 1 combination has 6 equivalent permutations). Thus there are  $120 \div 6 = 20$  combinations where all three dice have different numbers. The total number of combinations is the sum of those in each category or  $6 + 30 + 20 = 56$ . The correct answer is C.

43. The simplest way to solve this problem is to analyze one row at a time, and one square at a time in each row if necessary. Let's begin with the top row. First, let's place a letter in left box; we have a choice of 3 different letters for this box: X, Y, or Z. Next, we place a letter in the top center box. Now we have only 2 options so as not to match the letter we placed in the left box. Finally, we only have 1 letter to choose for the right box so as not to match either of the letters in the first two boxes. Thus, we have  $3 \times 2 \times 1$  or 6 ways to fill in the top row without duplicating a letter across it. Now let's analyze the middle row by assuming that we already have a particular arrangement of the top row, say the one given in the example above (XYZ).

X	Y	Z	Given Arrangement of Top Row
Middle Row LEFT Options	Middle Row CENTER Options	Middle Row RIGHT Options	
Y	X	Z	Not Allowed: Z is in Right column twice
	Z	X	Permissible
Z	X	Y	Permissible
	Y	X	Not Allowed: Y is in Center column twice

Now let's analyze the bottom row by assuming that we already have a particular arrangement of the top and middle rows. Again, let's use top and middle row arrangements given in the example above.

X	Y	Z	Given Arrangement of Top Row
Y	Z	X	Give Arrangement of Middle Row
Bottom Row LEFT Options	Bottom Row CENTER Options	Bottom Row RIGHT Options	
Z	X	Y	Only this option is permissible.

We can see that given fixed top and middle rows, there is only 1 possible bottom row that will work. (In other words, the 3rd row is completely determined by the arrangement of the 1st and 2nd rows). By combining the information about each row, we calculate the solution as follows: 6 possible top rows  $\times$  2 possible middle rows  $\times$  1 possible bottom row = 12 possible grids. The correct answer is D.

44. This is a counting problem that is best solved using logic. First, let's represent the line of women as follows:

0000  
0000

where the heights go from 1 to 8 in increasing order and the unknowns are designated 0s. Since the women are arranged by their heights in increasing order from left to right and front to back, we know that at a minimum, the lineup must conform to this:

0008  
1000

Let's further designate the arrangement by labeling the other individuals in the top row as X, Y and Z, and the individuals in the bottom row as A, B, and C.

XYZ8  
1ABC

Note that Z must be greater than at least 5 numbers (X, Y, B, A, and 1) and less than at least 1 number (8). This means that Z can only be a 6 or a 7. Note that Y must be greater than at least 3 numbers (X, A and 1) and less than at least 2 numbers (8 and Z). This means that Y can only be 4, 5, or 6. Note that X must be greater than at least 1 number (1) and less than at least 3 numbers (8, Z and Y). This means that X must be 2, 3, 4, or 5. This is enough information to start counting the total number of possibilities for the top row. It will be easiest to use the middle unknown value Y as our starting point. As we determined above, Y can only be 4, 5, or 6. Let's check each case, making our conclusions logically: *If Y is 4*, Z has 2 options (6 or 7) and X has 2 options (2 or 3). This yields  $2 \times 2 = 4$  possibilities. *If Y is 5*, Z has 2 options (6 or 7), and X has 3 options (2, 3, or 4). This yields  $2 \times 3 = 6$  possibilities. *If Y is 6*, Z has 1 option (7), and X has 4 options (2, 3, 4, or 5). This yields  $1 \times 4 = 4$  possibilities. For each of the possibilities above, the bottom row is completely determined because we have 3 numbers left, all of which must be in placed increasing order. Hence, there are  $4 + 6 + 4 = 14$  ways for the women to pose. The correct answer is (B).

45. One way to approach this problem is to pick an actual number to represent the variable  $n$ . This helps to make the problem less abstract. Let's assume that  $n = 6$ . Since each of the regional offices must be represented by exactly one candidate on the committee, the committee must consist of 6 members. Further, because the committee must have an equal number of male and female employees, it must include 3 men and 3 women. First, let's form the female group of the committee. There are 3 women to be selected from 6 female candidates (one per region). One possible team selection can be represented as follows, where A, B, C, D, E, & F represent the 6 female candidates:

A	B	C	D	E	F
Yes	Yes	Yes	No	No	No

In the representation above, women A, B, and C are on the committee, while women D, E, and F are not. There are many other possible 3 women teams. Using

the combination formula, the number of different combinations of three female committee members is  $6! / (3! \times 3!) = 720/36 = 20$ . To ensure that each region is represented by exactly one candidate, the group of men must be selected from the remaining three regions that are not represented by female employees. In other words, three of the regions have been “used up” in our selection of the female candidates. Since we have only 3 male candidates remaining (one for each of the three remaining regions), there is only one possible combination of 3 male employees for the committee. Thus, we have 20 possible groups of three females and 1 possible group of three males for a total of  $20 \times 1 = 20$  possible groups of six committee members. Now, we can plug 6 in for the variable  $n$  in each of the five answer choices. The answer choice that yields the solution 20 is the correct expression. Therefore, B is the correct answer since plugging 6 in for  $n$ , yields the

following: 
$$\frac{n!}{(.5n)!^2} = \frac{6!}{(3!)^2} = \frac{6 \times 5 \times 4 \times 3 \times 2 \times 1}{3 \times 2 \times 1 \times 3 \times 2 \times 1} = 20$$

46. The first thing to recognize here is that this is a *permutation with restrictions* question. In such questions it is always easiest to tackle the restricted scenario(s) first. The restricted case here is when all of the men actually sit together in three adjacent seats. Restrictions can often be dealt with by considering the limited individuals as one unit. In this case we have four women ( $w_1, w_2, w_3,$  and  $w_4$ ) and three men ( $m_1, m_2,$  and  $m_3$ ). We can consider the men as one unit, since we can think of the 3 adjacent seats as simply 1 seat. If the men are one unit ( $m$ ), we are really looking at seating 5 individuals ( $w_1, w_2, w_3, w_4,$  and  $m$ ) in 5 seats. There are  $5!$  ways of arranging 5 individuals in a row. This means that our group of three men is sitting in any of the “five” seats. Now, imagine that the one seat that holds the three men magically splits into three seats. How many different ways can the men arrange themselves in those three seats?  $3!$ . To calculate the total number of ways that the men and women can be arranged in 7 seats such that the men **ARE** sitting together, we must multiply these two values:  $5!3!$ . However this problem asks for the number of ways the theatre-goers can be seated such that the men are **NOT** seated three in a row. Logically, this must be equivalent to the following: (Total number of all seat arrangements) – (Number of arrangements with 3 men in a row). The total number of all seat arrangements is simply  $7!$  so the final calculation is  $7! - 5!3!$ . The correct answer is C.
47. It is important to first note that our point of reference in this question is all the possible subcommittees that include Michael. We are asked to find what percent of these subcommittees also include Anthony. Let's first find out how many possible subcommittees there are that must include Michael. If Michael must be on each of the three-person committees that we are considering, we are essentially choosing people to fill the two remaining spots of the committee. Therefore, the number of possible committees can be found by considering the number of different two-person groups that can be formed from a pool of 5 candidates (not 6 since Michael was already chosen). Using the anagram method to solve this combinations question, we assign 5 letters to the various board members in the first row. In the second row, two of the board members get assigned a Y to signify

that they were chosen and the remaining 3 get an N, to signify that they were not chosen:

A	B	C	D	E
Y	Y	N	N	N

The number of different combinations of two-person committees from a group of 5 board members would be the number of possible anagrams that could be formed from the word YYNNN =  $5! / (3!2!) = 10$ . Therefore there are 10 possible committees that include Michael. Out of these 10 possible committees, of how many will Anthony also be a member? If we assume that Anthony and Michael must be a member of the three-person committee, there is only one remaining place to fill. Since there are four other board members, there are four possible three-person committees with both Anthony and Michael. Of the 10 committees that include Michael, 4/10 or 40% also include Anthony. **The correct answer is C.** As an alternate method, imagine splitting the original six-person board into two equal groups of three. Michael is automatically in one of those groups of three. Now, Anthony could occupy any one of the other 5 positions -- the 2 on Michael's committee and the 3 on the other committee. Since Anthony has an equal chance of winding up in any of those positions, his chance of landing on Michael's committee is 2 out of 5, or  $2/5 = 40\%$ . Since that probability must correspond to the ratio of committees asked for in the problem, the answer is achieved. Answer choice C is correct.

48. The easiest way to solve this question is to consider the restrictions separately. Let's start by considering the restriction that one of the parents must drive, temporarily ignoring the restriction that the two sisters won't sit next to each other. This means that...

- 2 people (mother or father) could sit in the driver's seat
- 4 people (remaining parent or one of the children) could sit in the front passenger seat
- 3 people could sit in the first back seat
- 2 people could sit in the second back seat
- 1 person could sit in the remaining back seat

The total number of possible seating arrangements would be the product of these various possibilities:  $2 \times 4 \times 3 \times 2 \times 1 = 48$ . We must subtract from these 48 possible seating arrangements the number of seating arrangements in which the daughters are sitting together. The only way for the daughters to sit next to each other is if they are both sitting in the back. This means that...

- 2 people (mother or father) could sit in the driver's seat
- 2 people (remaining parent or son) could sit in the front passenger seat

Now for the back three seats we will do something a little different. The back three seats must contain the two daughters and the remaining person (son or parent). To find out the number of arrangements in which the daughters are sitting adjacent, let's consider the two daughters as one unit. The remaining person (son or parent) is the other unit. Now, instead of three seats to fill, we only have two "seats," or units, to fill.

There are  $2 \times 1 = 2$  ways to seat these two units.

However, the daughter-daughter unit could be  $d_1d_2$  or  $d_2d_1$

We must consider both of these possibilities so we multiply the 2 by 2! for a total of 4 seating possibilities in the back. We could also have manually counted these possibilities:

$d_1d_2X, d_2d_1X, Xd_1d_2, Xd_2d_1$

Now we must multiply these 4 back seat scenarios by the front seat scenarios we calculated earlier:

$$(2 \times 2) \times 4 = 16$$

front back

If we subtract these 16 "daughters-sitting-adjacent" scenarios from the total number of "parent-driving" scenarios, we get:  $48 - 16 = 32$  The correct answer is B.

49.

Ignoring Frankie's requirement for a moment, observe that the six mobsters can be arranged  $6!$  or  $6 \times 5 \times 4 \times 3 \times 2 \times 1 = 720$  different ways in the concession stand line. In each of those 720 arrangements, Frankie must be either ahead of or behind Joey. Logically, since the combinations favor neither Frankie nor Joey, each would be behind the other in precisely half of the arrangements. Therefore, in order to satisfy Frankie's requirement, the six mobsters could be arranged in  $720/2 = 360$  different ways. The correct answer is D.

50.

We can imagine that the admissions committee will choose a "team" of students to receive scholarships. However, because there are three different levels of scholarships, it will not suffice to simply count the number of possible "scholarship teams." In other words, the committee must also place the "scholarship team" members according to scholarship level. So, order matters. If we knew the number of scholarships to be granted at each of the three scholarship levels, we could use the anagram method to count the number of ways the scholarships could be doled out among the 10 applicants. To show that this is true, let's invent a hypothetical case for which there are 3 scholarships to be granted at each of the three levels. If we assign letters to the ten applicants from A to J, and if T represents a \$10,000 scholarship, F represents a \$5,000 scholarship, O represents a \$1,000 scholarship, and N represents no scholarship, then the anagram grid would look like this:

A	B	C	D	E	F	G	H	I	J
T	T	T	F	F	F	O	O	O	N

Our "word" is TTTFFFOOON. To calculate the number of different "spellings" of this "word," we use the following shortcut:

10!

$$\frac{10!}{(3!)(3!)(3!)(1!)}$$

The 10 represents the 10 total applicants, the 3's represent the 3 T's, 3 F's, and 3 O's, and the 1 represents the 1 N. Simplifying this expression would yield the number of ways to distribute the scholarships among the 10 applicants. So, knowing the number of scholarships to be granted at each of the three scholarship levels allows us to calculate the answer to the question. Therefore, the rephrased question is: "How many scholarships are to be granted at each of the three scholarship levels?" (1) INSUFFICIENT: While this tells us the total number of scholarships to be granted, we still don't know how many from each level will be granted. (2) INSUFFICIENT: While this tells us that the number of scholarships from each level will be equal, we still don't know how many from each level will be granted. (1) AND (2) SUFFICIENT: If there are 6 total scholarships to be granted and the same number from each level will be granted, there will be two \$10,000 scholarships, two \$5,000 scholarships, and two \$1,000 scholarships granted. The correct answer is C.

51.

In order to know how many panels we can form when choosing three women and two men, we need to know how many women and men we have to choose from. In this case, we need to know the value of  $x$  (the number of women to choose from) and the value of  $y$  (the number of men to choose from). The number of panels will be equal to the number of groups of three that could be chosen from  $x$  women multiplied by the number of groups of two that could be chosen from  $y$  men. (1) INSUFFICIENT: This statement tells us that choosing 3 from  $x + 2$  would yield 56 groups. One concept that you need to know for the exam is that when dealing with combinations and permutations, each result corresponds to a unique set of circumstances. For example, if you have  $z$  people and know that choosing two of them would result in 15 different possible groups of two, it must be true that  $z = 6$ . No other value of  $z$  would yield exactly 15 different groups of two. So if you know how many subgroups of a certain size you can choose from an unknown original larger group, you can deduce the size of the larger group. In the present case, we know that choosing three women from  $x + 2$  women would yield 56 groups of 3. These numbers must correspond to a specific value of  $x$ . Do not worry if you do not know what value of  $x$  would yield these results (in this case,  $x$  must equal 6, because the only way to obtain 56 groups if choosing 3 is to choose from a group of 8. Since the statement tells us that 8 is 2 more than the value of  $x$ ,  $x$  must be 6). The GMAT does not expect you to memorize all possible results. It is enough to understand the underlying concept: if you know the number of groups yielded (in this case 56), then you know that there is only one possible value of  $x$ . (2) INSUFFICIENT: Knowing only that  $x = y + 1$  tells us nothing specific about the values of  $x$  and  $y$ . Infinitely many values of  $x$  and  $y$  satisfy this equation, thus yielding infinitely many answers to the question. (1) AND (2) SUFFICIENT: Taking the statements together, we know that (1) gives

us the value of  $x$  and that (2) allows us to use that value of  $x$  to determine the value of  $y$ . Remember that, with data sufficiency, we do not actually need to calculate the values for  $x$  and  $y$ ; it is enough to know that we *can* calculate them. The correct answer is C.

52.

This problem cannot be solved through formula. Given that the drawer contains at least three socks of each color, we know that at least one matched pair of each color can be removed. From the first nine socks, we can therefore make three pairs, leaving three 'orphans.' To think through the problem, it is useful to conceptualize removing those nine socks from the drawer. We will need additional information about any socks left in the drawer to solve the problem.

(1) INSUFFICIENT: Once those first nine socks have been removed, only two socks remain, but we do not have sufficient information about the color of the two socks to solve the problem. If the two remaining socks are a matched pair, we can add this final pair to the first three. This scenario results in four pairs and three orphans. However, if the final two socks are mismatched, each will make a new pair with one of the original three orphans, resulting in five pairs and one orphan.

(2) INSUFFICIENT: This statement gives no information about how many socks are in the drawer.

(1) AND (2) INSUFFICIENT: Given that the drawer contains 11 socks and that there are an equal number of black and gray socks, there are two possible scenarios. Three black, three gray, and five blue socks would yield four pairs total. Four black, four gray, and three blue socks would yield five pairs total.

The correct answer is E.

53.

There are  $3 \times 2 \times 4 = 24$  possible different shirt-sweater-hat combinations that Kramer can wear. He wears the first one on a Wednesday. The following Wednesday he will wear the 8th combination. The next Wednesday after that he will wear the 15th combination. The next Wednesday after that he will wear the 22nd combination. On Thursday, he will wear the 23rd combination and on Friday he will wear the 24th combination.

Thus, the first day on which it will no longer be possible to wear a new combination is Saturday. The correct answer is E.

54.

$$C(4,1)C(6,2)+C(4,2)C(6,1)+C(4,3)=60+36+4=100$$

55.

$$C(9,1)C(9,1)C(8,1)C(7,1)=4536$$

# Probability

1.

There are 2 possible outcomes on each flip: heads or tails. Since the coin is flipped three times, there are  $2 \times 2 \times 2 = 8$  total possibilities: HHH, HHT, HTH, HTT, TTT, TTH, THT, THH. Of these 8 possibilities, how many involve exactly two heads? We can simply count these up: HHT, HTH, THH. We see that there are 3 outcomes that involve exactly two heads. Thus, the correct answer is  $3/8$ .

Alternatively, we can draw an anagram table to calculate the number of outcomes that involve exactly 2 heads.

A	B	C
H	H	T

The top row of the anagram table represents the 3 coin flips: A, B, and C. The bottom row of the anagram table represents one possible way to achieve the desired outcome of exactly two heads. The top row of the anagram yields  $3!$ , which must be divided by  $2!$  since the bottom row of the anagram table contains 2 repetitions of the letter H. There are  $3!/2! = 3$  different outcomes that contain exactly 2 heads.

The probability of the coin landing on heads exactly twice is ( $\#$  of two-head results)  $\div$  (total  $\#$  of outcomes) =  $3/8$ . The correct answer is B.

2.

Let us say that there are  $n$  questions on the exam. Let us also say that  $p_1$  is the probability that Patty will get the first problem right, and  $p_2$  is the probability that Patty will get the second problem right, and so on until  $p_n$ , which is the probability of getting the last problem right. Then the probability that Patty will get all the questions right is just  $p_1 \times p_2 \times \dots \times p_n$ . We are being asked whether  $p_1 \times p_2 \times \dots \times p_n$  is greater than 50%.

(1) INSUFFICIENT: This tells us that for each question, Patty has a 90% probability of answering correctly. However, without knowing the number of questions, we cannot determine the probability that Patty will get all the questions correct.

(2) INSUFFICIENT: This gives us some information about the number of questions on the exam but no information about the probability that Patty will answer any one question correctly.

(1) AND (2) INSUFFICIENT: Taken together, the statements still do not provide a definitive "yes" or "no" answer to the question. For example, if there are only 2 questions on the exam, Patty's probability of answering all the questions correctly is equal to  $.90 \times .90 = .81 = 81\%$ . On the other hand if there are 7 questions on the exam, Patty's probability of answering all the questions correctly is equal to  $.90 \times .90 \times .90 \times .90 \times .90 \times .90 \times .90 \approx 48\%$ . We cannot determine whether Patty's chance of getting a perfect score on the exam is greater than 50%.

The correct answer is E

3.

In order to solve this problem, we have to consider two different scenarios. In the first scenario, a woman is picked from room A and a woman is picked from room B. In the second scenario, a man is picked from room A and a woman is picked from room B.

The probability that a woman is picked from room A is  $10/13$ . If that woman is then added to room B, this means that there are 4 women and 5 men in room B (Originally there were 3 women and 5 men). So, the probability that a woman is picked from room B is  $4/9$ .

Because we are calculating the probability of picking a woman from room A AND then from room B, we need to multiply these two probabilities:

$$10/13 \times 4/9 = 40/117$$

The probability that a man is picked from room A is  $\frac{3}{13}$ . If that man is then added to room B, this means that there are 3 women and 6 men in room B. So, the probability that a woman is picked from room B is  $\frac{3}{9}$ .

Again, we multiply these two probabilities:

$$\frac{3}{13} \times \frac{3}{9} = \frac{9}{117}$$

To find the total probability that a woman will be picked from room B, we need to take both scenarios into account. In other words, we need to consider the probability of picking a woman and a woman OR a man and a woman. In probabilities, OR means addition. If we add the two probabilities, we get:

$$\frac{40}{117} + \frac{9}{117} = \frac{49}{117}$$

The correct answer is B.

#### 4.

The period from July 4 to July 8, inclusive, contains  $8 - 4 + 1 = 5$  days, so we can rephrase the question as "What is the probability of having exactly 3 rainy days out of 5?"

Since there are 2 possible outcomes for each day (R = rain or S = shine) and 5 days total, there are  $2 \times 2 \times 2 \times 2 \times 2 = 32$  possible scenarios for the 5 day period (RRRSS, RSRSS, SSRRR, etc...)

To find the probability of having exactly three rainy days out of five, we must find the total number of scenarios containing exactly 3 R's and 2 S's, that is the number of possible RRRSS anagrams:

$$= \frac{5!}{2!3!} = \frac{(5 \times 4)}{2 \times 1} = 10$$

The probability then of having exactly 3 rainy days out of five is  $\frac{10}{32}$  or  $\frac{5}{16}$ .

Note that we were able to calculate the probability this way because the probability that any given scenario would occur was the same. This stemmed from the fact that the probability of rain = shine = 50%. Another way to solve this question would be to find the probability that one of the favorable scenarios would occur and to multiply that by the number of favorable scenarios. In this case, the probability that RRRSS (1st three days rain, last two shine) would occur is  $(\frac{1}{2})(\frac{1}{2})(\frac{1}{2})(\frac{1}{2})(\frac{1}{2}) = \frac{1}{32}$ . There are 10 such scenarios (different anagrams of RRRSS) so the overall probability of exactly 3 rainy days out of 5 is again  $\frac{10}{32}$ . This latter method works even when the likelihood of rain does not equal the likelihood of shine.

The correct answer is C.

#### 5.

There are four possible ways to pick exactly one defective car when picking four cars: DFFF, FDFF, FFDF, FFFD (D = defective, F = functional).

To find the total probability we must find the probability of each one of these scenarios and add them together (we add because the total probability is the first scenario OR the second OR...).

The probability of the first scenario is the probability of picking a defective car first ( $\frac{3}{20}$ ) AND then a functional car ( $\frac{17}{19}$ ) AND then another functional car ( $\frac{16}{18}$ ) AND then another functional car ( $\frac{15}{17}$ ).

The probability of this first scenario is the product of these four probabilities:

$$\frac{3}{20} \times \frac{17}{19} \times \frac{16}{18} \times \frac{15}{17} = \frac{2}{19}$$

The probability of each of the other three scenarios would also be  $\frac{2}{19}$  since the chance of getting the D first is the same as getting it second, third or fourth.

The total probability of getting exactly one defective car out of four =  $\frac{2}{19} + \frac{2}{19} + \frac{2}{19} + \frac{2}{19} = \frac{8}{19}$ .

#### 6.

The simplest way to solve the problem is to recognize that the total number of gems in the bag must be a multiple of 3, since we have  $\frac{2}{3}$  diamonds and  $\frac{1}{3}$  rubies. If we had a total number that was not divisible by 3, we would not be able to divide the stones into thirds. Given this fact, we can test some multiples of 3 to see whether any fit the description in the question.

The smallest number of gems we could have is 6: 4 diamonds and 2 rubies (since we need at

least 2 rubies). Is the probability of selecting two of these diamonds equal to  $5/12$ ?  
 $4/6 \times 3/5 = 12/30 = 2/5$ . Since this does not equal  $5/12$ , this cannot be the total number of gems.

The next multiple of 3 is 9, which yields 6 diamonds and 3 rubies:

$6/9 \times 5/8 = 30/72 = 5/12$ . Since this matches the probability in the question, we know we have 6 diamonds and 3 rubies. Now we can figure out the probability of selecting two rubies:

$$3/9 \times 2/8 = 6/72 = 1/12$$

The correct answer is C.

7.

For probability, we always want to find the number of ways the requested event could happen and divide it by the total number of ways that any event could happen.

For this complicated problem, it is easiest to use combinatorics to find our two values. First, we find the total number of outcomes for the triathlon. There are 9 competitors; three will win medals and six will not. We can use the Combinatorics Grid, a counting method that allows us to determine the number of combinations without writing out every possible combination.

A	B	C	D	E	F	G	H	I
Y	Y	Y	N	N	N	N	N	N

Out of our 9 total places, the first three, A, B, and C, win medals, so we label these with a "Y." The final six places (D, E, F, G, H, and I) do not win medals, so we label these with an "N." We translate this into math:  $9! / 3!6! = 84$ . So our total possible number of combinations is 84.

(Remember that ! means factorial; for example,  $6! = 6 \times 5 \times 4 \times 3 \times 2 \times 1$ .)

Note that although the problem seemed to make a point of differentiating the first, second, and third places, our question asks only whether the brothers will medal, not which place they will win. This is why we don't need to worry about labeling first, second, and third place distinctly.

Now, we need to determine the number of instances when at least two brothers win a medal.

Practically speaking, this means we want to add the number of instances two brothers win to the number of instances three brothers win.

Let's start with all three brothers winning medals, where B represents a brother.

A	B	C	D	E	F	G	H	I
B	B	B	N	N	N	N	N	N

Since all the brothers win medals, we can ignore the part of the counting grid that includes those who don't win medals. We have  $3! / 3! = 1$ . That is, there is only one instance when all three brothers win medals.

Next, let's calculate the instances when exactly two brothers win medals.

A	B	C	D	E	F	G	H	I
B	B	Y	B'	N	N	N	N	N

Since brothers both win and don't win medals in this scenario, we need to consider both sides of the grid (i.e. the ABC side and the DEFGHI side). First, for the three who win medals, we have  $3! / 2! = 3$ . For the six who don't win medals, we have  $6! / 5! = 6$ . We multiply these two numbers to get our total number:  $3 \times 6 = 18$ .

Another way to consider the instances of at least two brothers medaling would be to think of simple combinations with restrictions.

If you are choosing 3 people out of 9 to be winners, how many different ways are there to choose a specific set of 3 from the 9 (i.e. all the brothers)? Just one. Therefore, there is only one scenario of all three brothers medaling.

If you are choosing 3 people out of 9 to be winners, if 2 specific people of the 9 have to be a member of the winning group, how many possible groups are there? It is best to think of this as a problem of choosing 1 out of 7 (2 must be chosen). Choosing 1 out of 7 can be represented as  $7! / 1!6! = 7$ . However, if 1 of the remaining 7 can not be a member of this group (in this case

the 3rd brother) there are actually only 6 such scenarios. Since there are 3 different sets of exactly two brothers ( $B_1B_2$ ,  $B_1B_3$ ,  $B_2B_3$ ), we would have to multiply this 6 by 3 to get 18 scenarios of only two brothers medaling.

The brothers win at least two medals in  $18 + 1 = 19$  circumstances. Our total number of circumstances is 84, so our probability is  $19 / 84$ .

The correct answer is B.

### 8.

If set  $S$  is the set of all prime integers between 0 and 20 then:

$$S = \{2, 3, 5, 7, 11, 13, 17, 19\}$$

Let's start by finding the probability that the product of the three numbers chosen is a number less than 31. To keep the product less than 31, the three numbers must be 2, 3 and 5. So, what is the probability that the three numbers chosen will be some combination of 2, 3, and 5?

Here's the list all possible combinations of 2, 3, and 5:

case A: 2, 3, 5

case B: 2, 5, 3

case C: 3, 2, 5

case D: 3, 5, 2

case E: 5, 2, 3

case F: 5, 3, 2

This makes it easy to see that when 2 is chosen first, there are two possible combinations. The same is true when 3 and 5 are chosen first. The probability of drawing a 2, AND a 3, AND a 5 in case A is calculated as follows (remember, when calculating probabilities, AND means multiply):

$$\text{case A: } (1/8) \times (1/7) \times (1/6) = 1/336$$

The same holds for the rest of the cases.

$$\text{case B: } (1/8) \times (1/7) \times (1/6) = 1/336$$

$$\text{case C: } (1/8) \times (1/7) \times (1/6) = 1/336$$

$$\text{case D: } (1/8) \times (1/7) \times (1/6) = 1/336$$

$$\text{case E: } (1/8) \times (1/7) \times (1/6) = 1/336$$

$$\text{case F: } (1/8) \times (1/7) \times (1/6) = 1/336$$

So, a 2, 3, and 5 could be chosen according to case A, OR case B, OR, case C, etc. The total probability of getting a 2, 3, and 5, in any order, can be calculated as follows (remember, when calculating probabilities, OR means add):

$$(1/336) + (1/336) + (1/336) + (1/336) + (1/336) + (1/336) = 6/336$$

Now, let's calculate the probability that the sum of the three numbers is odd. In order to get an odd sum in this case, 2 must NOT be one of the numbers chosen. Using the rules of odds and evens, we can see that having a 2 would give the following scenario:

$$\text{even} + \text{odd} + \text{odd} = \text{even}$$

So, what is the probability that the three numbers chosen are all odd? We would need an odd AND another odd, AND another odd:

$$(7/8) \times (6/7) \times (5/6) = 210/336$$

The positive difference between the two probabilities is:

$$(210/336) - (6/336) = (204/336) = 17/28$$

The **correct answer is C**.

### 9.

To find the probability of forming a code with two adjacent I's, we must find the total number of such codes and divide by the total number of possible 10-letter codes.

The total number of possible 10-letter codes is equal to the total number of anagrams that can be formed using the letters ABCDEFGHII, that is  $10!/2!$  (we divide by  $2!$  to account for repetition of the I's).

To find the total number of 10 letter codes with two adjacent I's, we can consider the two I's as ONE LETTER. The reason for this is that for any given code with adjacent I's, wherever one I is

positioned, the other one must be positioned immediately next to it. For all intents and purposes, we can think of the 10 letter codes as having 9 letters (I-I is one). There are 9! ways to position 9 letters.

$$\text{Probability} = (\# \text{ of adjacent I codes}) / (\# \text{ of total possible codes}) \\ = 9! \div (10! / 2!) = (9!2! / 10!) = (9!2! / 10(9!)) = 1/5$$

The correct answer is C.

### 10.

If we factor the right side of the equation, we can come up with a more meaningful relationship between  $p$  and  $q$ :  $p^2 - 13p + 40 = q$  so  $(p - 8)(p - 5) = q$ . We know that  $p$  is an integer between 1 and 10, inclusive, so there are ten possible values for  $p$ . We see from the factored equation that the sign of  $q$  will depend on the value of  $p$ . One way to solve this problem would be to check each possible value of  $p$  to see whether it yields a positive or negative  $q$ .

However, we can also use some logic here. For  $q$  to be negative, the expressions  $(p - 8)$  and  $(p - 5)$  must have opposite signs. Which integers on the number line will yield opposite signs for the expressions  $(p - 8)$  and  $(p - 5)$ ? Those integers in the range  $5 < p < 8$  (notice 5 and 8 are not included because they would both yield a value of zero and zero is a nonnegative integer). That means that there are only two integer values for  $p$ , 6 and 7, that would yield a negative  $q$ . With a total of 10 possible  $p$  values, only 2 yield a negative  $q$ , so the probability is  $2/10$  or  $1/5$ .

The correct answer is B.

### 11.

Let's consider the different scenarios:

If Kate wins all five flips, she ends up with \$15.

If Kate wins four flips, and Danny wins one flip, Kate is left with \$13.

If Kate wins three flips, and Danny wins two flips, Kate is left with \$11.

If Kate wins two flips, and Danny wins three flips, Kate is left with \$9.

If Kate wins one flip, and Danny wins four flips, Kate is left with \$7.

If Kate loses all five flips, she ends up with \$5.

The question asks for the probability that Kate will end up with more than \$10 but less than \$15. In other words, we need to determine the probability that Kate is left with \$11 or \$13 (since there is no way Kate can end up with \$12 or \$14).

#### **The probability that Kate ends up with \$11 after the five flips:**

Since there are 2 possible outcomes on each flip, and there are 5 flips, the total number of possible outcomes is  $2 \times 2 \times 2 \times 2 \times 2 = 32$ . Thus, the five flips of the coin yield 32 different outcomes.

To determine the probability that Kate will end up with \$11, we need to determine how many of these 32 outcomes include a combination of exactly three winning flips for Kate.

We can create a systematic list of combinations that include three wins for Kate and two wins for Danny: DKKKD, DKKDK, DKDKK, DDKKK, KDKKD, KDKDK, KDDKK, KKDKD, KKDDK, KKKDD = 10 ways.

Alternatively, we can consider each of the five flips as five spots. There are 5 potential spots for Kate's first win. There are 4 potential spots for Kate's second win (because one spot has already been taken by Kate's first win). There are 3 potential spots for Kate's third win. Thus, there are  $5 \times 4 \times 3 = 60$  ways for Kate's three victories to be ordered.

However, since we are interested only in unique winning combinations, this number must be reduced due to overcounting. Consider the winning combination KKKDD: This one winning combination has actually been counted 6 times (this is  $3!$  or three factorial) because there are 6 different orderings of this one combination:

$K_1K_2K_3DD, K_1K_3K_2DD, K_2K_3K_1DD, K_2K_1K_3DD, K_3K_2K_1DD, K_3K_1K_2DD$

This overcounting by 6 is true for all of Kate's three-victory combinations. Therefore, there are only  $60 \div 6 = 10$  ways for Kate to have three wins and end up with \$11 (as we had discovered earlier from our systematic list).

### **The probability that Kate ends up with \$13 after the five flips:**

To determine the probability that Kate will end up with \$13, we need to determine how many of the 32 total possible outcomes include a combination of exactly four winning flips for Kate.

Again, we can create a systematic list of combinations that include four wins for Kate and one win for Danny: KKKKD, KKKDK, KKDKK, KDKKK, DKKKK = 5 ways.

Alternatively, using the same reasoning as above, we can determine that there are  $5 \times 4 \times 3 \times 2 = 120$  ways for Kate's four victories to be ordered. Then, reduce this by  $4!$  (four factorial) or 24 due to overcounting. Thus, there are  $120 \div 24 = 5$  ways for Kate to have four wins and end up with \$13 (the same answer we found using the systematic list).

### **The total probability that Kate ends up with either \$11 or \$13 after the five flips:**

There are 10 ways that Kate is left with \$11. There are 5 ways that Kate is left with \$13.

Therefore, there are 15 ways that Kate is left with more than \$10 but less than \$15.

Since there are 32 possible outcomes, the correct answer is  $\frac{15}{32}$ , answer choice **D**.

## **12.**

There is a strong temptation to solve this problem by simply finding the probability that it will snow (90%) and the probability that schools will be closed (80%) and multiplying these two probabilities. This approach would yield the incorrect answer (72%), choice D.

However, it is only possible to multiply probabilities of separate events if you know that they are independent from each other. This fact is not provided in the problem. In fact, we would assume that school being closed and snow are, at least to some extent, dependent on each other.

However, they are not entirely dependent on each other; it is possible for either one to happen without the other. Therefore, there is an unknown degree of dependence; hence there is a range of possible probabilities, depending on to what extent the events are dependent on each other.

Set up a matrix as shown below. Fill in the probability that schools will not be closed and the probability that there will be no snow.

	Schools closed	Schools not closed	TOTAL
Snow			
No snow			<b>10</b>
<b>TOTAL</b>		<b>20</b>	<b>100</b>

Then use subtraction to fill in the probability that schools will be closed and the probability that there will be snow.

	Schools closed	Schools not closed	TOTAL
Snow			<b>90</b>
No snow			<b>10</b>
<b>TOTAL</b>	<b>80</b>	<b>20</b>	<b>100</b>

To find the greatest possible probability that schools will be closed and it will snow, fill in the remaining cells with the largest possible number in the upper left cell.

	Schools closed	Schools not closed	TOTAL
Snow	<b>80</b>	10	<b>90</b>
No snow	0	10	<b>10</b>
<b>TOTAL</b>	<b>80</b>	<b>20</b>	<b>100</b>

The greatest possible probability that schools will be closed and it will snow is 80%. The correct answer is E.

### 13.

The easiest way to attack this problem is to pick some real, easy numbers as values for  $y$  and  $n$ . Let's assume there are 3 travelers (A, B, C) and 2 different destinations (1, 2). We can chart out the possibilities as follows:

Destination 1	Destination 2
ABC	
AB	C
AC	B
BC	A
	ABC
C	AB
B	AC
A	BC

Thus there are 8 possibilities and in 2 of them all travelers end up at the same destination. Thus the probability is  $2/8$  or  $1/4$ . By plugging in  $y = 3$  and  $n = 2$  into each answer choice, we see that only answer choice D yields a probability of  $1/4$ .

Alternatively, consider that each traveler can end up at any one of  $n$  destinations. Thus, for each traveler there are  $n$  possibilities. Therefore, for  $y$  travelers, there are  $n^y$  possible outcomes.

Additionally, the "winning" outcomes are those where all travelers end up at the same destination. Since there are  $n$  destinations there are  $n$  "winning" outcomes.

$$\text{Thus, the probability} = \frac{\text{winning outcomes}}{\text{total outcomes}} = \frac{n}{n^y} = \frac{1}{n^{y-1}}.$$

The answer is D.

#### 14.

There are four scenarios in which the plane will crash. Determine the probability of each of these scenarios individually:

$$\text{CASE ONE: Engine 1 fails, Engine 2 fails, Engine 3 works} = \frac{1}{3} \times \frac{1}{4} \times \frac{1}{2} = \frac{1}{24}$$

$$\text{CASE TWO: Engine 1 fails, Engine 2 works, Engine 3 fails} = \frac{1}{3} \times \frac{3}{4} \times \frac{1}{2} = \frac{3}{24}$$

$$\text{CASE THREE: Engine 1 works, Engine 2 fails, Engine 3 fails} = \frac{2}{3} \times \frac{1}{4} \times \frac{1}{2} = \frac{2}{24}$$

$$\text{CASE FOUR: Engine 1 fails, Engine 2 fails, Engine 3 fails} = \frac{1}{3} \times \frac{1}{4} \times \frac{1}{2} = \frac{1}{24}$$

To determine the probability that any one of these scenarios will occur, sum the four probabilities:

$$\frac{1}{24} + \frac{3}{24} + \frac{2}{24} + \frac{1}{24} = \frac{7}{24}$$

The correct answer is D. There is a  $7/24$  chance that the plane will crash in any given flight.

#### 15.

The question requires us to determine whether Mike's odds of winning are better if he attempts 3 shots instead of 1. For that to be true, his odds of making 2 out of 3 must be better than his odds of making 1 out of 1.

There are two ways for Mike to at least 2 shots: Either he hits 2 and misses 1, or he hits all 3:

<b>Odds of hitting 2 and missing 1</b> $p \times p \times (1-p)$	<b># of ways to hit 2 and miss 1</b> 3 (HHM, HMH, MHH)	<b>Total Probability</b> $3p^2(1-p)$
<b>Odds of hitting all 3</b> $p \times p \times p$	<b># of ways to hit all 3</b> 1 (HHH)	$p^3$
Mike's probability of hitting <i>at least</i> 2 out of 3 free throws =		$3p^2(1-p) + p^3$

Now, we can rephrase the question as the following inequality:

Is  $3p^2(1-p) + p^3 > p$ ? (Are Mike's odds of hitting at least 2 of 3 greater than his odds of hitting 1 of 1?)

This can be simplified as follows:

$$3p^2(1-p) + p^3 > p$$

$$3p^2 - 3p^3 + p^3 > p$$

$$3p^2 - 2p^3 > p \quad (\text{we can divide by } p \text{ since } p > 0)$$

$$3p - 2p^2 > 1$$

$$-2p^2 + 3p - 1 > 0 \quad (\text{divide by } -2, \text{ flipping the inequality})$$

$$p^2 - 1.5p + .5 < 0$$

$$(p - .5)(p - 1) < 0$$

In order for this inequality to be true,  $p$  must be greater than .5 but less than 1 (since this is the only way to ensure that the left side of the equation is negative). But we already know that  $p$  is less than 1 (since Mike occasionally misses some shots). Therefore, we need to know whether  $p$  is greater than .5. If it is, then the inequality will be true, which means that Mike will have a better chance of winning if he takes 3 shots.

Statement 1 tells us that  $p < .7$ . This does not help us to determine whether  $p > .5$ , so statement 1 is not sufficient.

Statement 2 tells us that  $p > .6$ . This means that  $p$  must be greater than .5. This is sufficient to answer the question.

The correct answer is B: Statement (2) alone is sufficient, but statement (1) alone is not sufficient.

## 16.

Although this may be counter-intuitive at first, the probability that *any* card in the deck will be a heart before any cards are seen is  $13/52$  or  $1/4$ .

One way to understand this is to solve the problem analytically for any card by building a probability "tree" and summing the probability of all of its "branches."

For example, let's find the probability that the 2nd card dealt from the deck is a heart. There are two mutually exclusive ways this can happen: (1) both the first and second cards are hearts or (2) only the second card is a heart.

CASE 1: Using the multiplication rule, the probability that the first card is a heart AND the second card is a heart is equal to the probability of picking a heart on the first card (or  $13/52$ , which is the number of hearts in a full deck divided by the number of cards) times the probability of

picking a heart on the second card (or  $12/51$ , which is the number of hearts remaining in the deck divided by the number of cards remaining in the deck).

$$13/52 \times 12/51 = 12/204$$

CASE 2: Similarly, the probability that the first card is a non-heart AND the second card is a heart is equal to the probability that the first card is NOT a heart (or  $39/52$ ) times the probability of subsequently picking a heart on the 2nd card (or  $13/51$ ).

$$39/52 \times 13/51 = 39/204$$

Since these two cases are mutually exclusive, we can add them together to get the total probability of getting a heart as the second card:  $12/204 + 39/204 = 51/204 = 1/4$ .

We can do a similar analysis for any card in the deck, and, although the probability tree gets more complicated as the card number gets higher, the total probability that the  $n$ th card dealt will be a heart will always end up simplifying to  $1/4$ .

The correct answer is A.

### 17.

Since the first two digits of the license plate are known and there are 10 possibilities for each of the remaining two digits (each can be any digit from 0 to 9), the total number of combinations for digits on the license plate will equal  $10 \times 10 = 100$ .

Because there are only 3 letters that can be used for government license plates (A, B, or C), there are a total of nine two-letter combinations that could be on the license plate (3 possibilities for first letter  $\times$  3 possibilities for the second letter).

Given that we have 100 possible digit combinations and 9 possible letter combinations, the total number of vehicles to be inspected will equal  $100 \times 9 = 900$ .

Since it takes 10 minutes to inspect one vehicle, the police will have time to inspect 18 vehicles in three hours (3 hours = 180 minutes). Thus, the probability of locating the transmitter within the allotted time is  $18/900 = 1/50$ . The correct answer is D.

### 18.

Let's consider the different scenarios:

If Harriet wins all five flips, she ends up with \$15.

If Harriet wins four flips, and Tran wins one flip, Harriet is left with \$13.

If Harriet wins three flips, and Tran wins two flips, Harriet is left with \$11.

If Harriet wins two flips, and Tran wins three flips, Harriet is left with \$9.

If Harriet wins one flip, and Tran wins four flips, Harriet is left with \$7.

If Harriet loses all five flips, she ends up with \$5.

The question asks for the probability that Harriet will end up with more than \$10 but less than \$15. In other words, we need to determine the probability that Harriet is left with \$11 or \$13 (since there is no way Harriet can end up with \$12 or \$14).

**The probability that Harriet ends up with \$11 after the five flips:**

Since there are 2 possible outcomes on each flip, and there are 5 flips, the total number of possible outcomes is  $2 \times 2 \times 2 \times 2 \times 2 = 32$ . Thus, the five flips of the coin yield 32 different outcomes.

To determine the probability that Harriet will end up with \$11, we need to determine how many of these 32 outcomes include a combination of exactly three winning flips for Harriet and exactly two winning flips for Tran.

This is equivalent to figuring out the possible rearrangements of THREE H's and TWO T's in a FIVE letter word.

We can create a systematic list of combinations that include three wins for Harriet and two wins for Tran: THHHT, THHHT, THHTH, TTHHH, HTHHT, HTHTH, HTTHH, HHTHT, HHTTH, HHHTT = 10 ways.

Alternatively, we can count the combinations by applying the anagram method:

A	B	C	D	E
H	H	H	T	T

We take the factorial of the top and divide by the factorial of each repeated letter on the bottom. Since there are two repeated letters, we get  $5! / (3! * 2!) = 10$  combinations.

Thus the probability that Harriet ends up with exactly \$11 after 5 flips is  $10/32$ .

### **The probability that Harriet ends up with \$13 after the five flips:**

To determine the probability that Harriet will end up with \$13, we need to determine how many of the 32 total possible outcomes include a combination of exactly four winning flips for Harriet.

Again, we can create a systematic list of combinations that include four wins for Harriet and one win for Tran: HHHHT, HHHTH, HHTHH, HTHHH, THHHH = 5 ways.

Alternatively, using the same reasoning as above, we can write

A	B	C	D	E
H	H	H	H	T

The formula yields  $5! / 4! = 5$  combinations.

Thus the probability that Harriet ends up with exactly \$13 after 5 flips is  $5/32$ .

### **The total probability that Harriet ends up with either \$11 or \$13 after the five flips:**

There are 10 ways that Harriet is left with \$11. There are 5 ways that Harriet is left with \$13.

Therefore, there are 15 ways that Harriet is left with more than \$10 but less than \$15.

Since there are 32 possible outcomes, the correct answer is  $15/32$ .

Alternatively, we can observe that the two possible ways to "succeed" according to the terms of the problem are connected by a logical OR: Harriet can end up with \$11 OR \$13. When we have two avenues to success that are connected by a logical OR, we add the probabilities:

$$10/32 + 5/32 = 15/32.$$

The correct answer is D.

**19.**

For an overlapping set problem we can use a double-set matrix to organize our information and solve. The values here are percents, and no actual number of students is given or requested. Therefore, we can assign a value of 100 to the total number of students at College X. From the given information in the question we have:

	Blue Eyes	Not Blue Eyes	Total
Brown Hair			40
Not Brown Hair			60
Total	70	30	100

The question asks for the difference between maximum value and the minimum value of the central square, that is, the percent of students who have neither brown hair nor blue eyes. The maximum value is 30, as shown below:

	Blue Eyes	Not Blue Eyes	Total
Brown Hair	40	0	40
Not Brown Hair	30	30	60
Total	70	30	100

Therefore the maximum probability of picking such a person is 0.3.

Likewise, the minimum value of the central square is zero, as shown below:

	Blue Eyes	Not Blue Eyes	Total
Brown Hair	10	30	40
Not Brown Hair	60	0	60
Total	70	30	100

Therefore the minimum probability of picking such a person is 0, and the difference between the maximum and the minimum probability is 0.3.

**20.**

The chance of getting AT LEAST one pair of cards with the same value out of 4 dealt cards should be computed using the 1-x technique. That is, you should figure out the probability of getting NO PAIRS in those 4 cards (an easier probability to compute), and then subtract that probability from 1.

First card: The probability of getting NO pairs so far is 1 (since only one card has been dealt).

Second card: There is 1 card left in the deck with the same value as the first card. Thus, there are 10 cards that will NOT form a pair with the first card. We have 11 cards left in the deck.

Probability of NO pairs so far =  $10/11$ .

Third card: Since we have gotten no pairs so far, we have two cards dealt with different values.

There are 2 cards in the deck with the same values as those two cards. Thus, there are 8 cards that will not form a pair with either of those two cards. We have 10 cards left in the deck.

Probability of turning over a third card that does NOT form a pair in any way, GIVEN that we have NO pairs so far =  $8/10$ .

Cumulative probability of avoiding a pair BOTH on the second card AND on the third card = product of the two probabilities above =  $(10/11)(8/10) = 8/11$ .

Fourth card: Now we have three cards dealt with different values. There are 3 cards in the deck with the same values; thus, there are 6 cards in the deck that will not form a pair with any of the three dealt cards. We have 9 cards left in the deck.

Probability of turning over a fourth card that does NOT form a pair in any way, GIVEN that we have NO pairs so far =  $6/9$ .

Cumulative probability of avoiding a pair on the second card AND on the third card AND on the fourth card = cumulative product =  $(10/11) (8/10) (6/9) = 16/33$ .  
Thus, the probability of getting AT LEAST ONE pair in the four cards is  $1 - 16/33 = 17/33$ .  
The correct answer is C.

21. The probability that Memphis does NOT win the competition is equal to  $1 - p$ , where  $p$  is the probability that Memphis DOES win the competition. Statement (1) states that the probability that Memphis (or any of the other cities) does not win the competition is  $7/8$ . This explicitly answers the question so this statement alone is sufficient. Statement (2) gives us  $1/8$  as the value for  $p$ , the probability that Memphis DOES win the competition. We can use this to calculate the probability that Memphis does NOT win the competition:  $1 - 1/8 = 7/8$ . This statement alone is sufficient to answer the question. The correct answer is D
22.  $41/50$   
23.  $1/1770$   
24.  $2/9$   
25. \$3.6  
26.  $9/10$   
27.  $13/14$   
28.  $7/216$   
29.  $2/25$   
30.  $\frac{1}{2}$   
31.  $8/25$   
32.  $1/24$   
33. B  
34. A  
35. B  
36. C  
37. D  
38. B  
39.  $4/7$   
40. A

# MISCELLANEOUS

1. To determine the greatest possible number of contributors we must assume that each of these individuals contributed the minimum amount, or \$50. We can then set up an inequality in which  $n$  equals the number of contributors:

$50n$  is less than or equal to \$1,749

Divide both sides of the equation by 50 to isolate  $n$ , and get

$n$  is less than or equal to 34.98

Since  $n$  represents individual people, it must be the greatest whole number less than 34.98. Thus, the greatest possible value of  $n$  is 34.

Alternately, we could have assumed that the fundraiser collected \$1,750 rather than \$1,749. If it had, and we assumed each individual contributed the minimum amount, there would have been exactly 35 contributors ( $\$50 \times 35 = \$1,750$ ). Since the fundraiser actually raised one dollar less than \$1,750, there must have been one fewer contributor, or 34.

The correct answer is B.

2.

It may be easiest to represent the ages of Joan, Kylie, Lillian and Miriam ( $J$ ,  $K$ ,  $L$  and  $M$ ) on a number line. If we do so, we will see that the ages represent consecutive integers as shown in the diagram.



Since the ages are consecutive integers, they can all be expressed in terms of  $L$ :  $L$ ,  $L + 1$ ,  $L + 2$ ,  $L + 3$ . The sum of the four ages then would be  $4L + 6$ . Since  $L$  must be an integer (it's Lillian's age), the expression  $4L + 6$  describes a number that is two more than a multiple of 4:

$$4L + 6 = (4L + 4) + 2$$

[ $4L + 4$  describes a multiple of 4, since it can be factored into  $4(L + 1)$  or  $4 \times$  an integer.]

54 is the only number in the answer choices that is two more than a multiple of 4 (namely, 52).

The correct answer is D.

3. This is an algebraic translation problem dealing with ages. For this type of problem, an age chart can help us keep track of the variables:

	NOW	IN 6 YEARS
JANET	$J$	$J + 6$
CAROL	$C$	$C + 6$

Using the chart in combination with the statements given in the question, we can derive equations to relate the variables. The first statement tells us that Janet is now 25 years younger than her mother Carol. Since we have used  $J$  to represent Janet's current age, and  $C$  to represent Carol's current age, we can translate the statement as follows:  $J = C - 25$ .

The second statement tells us that Janet will be half Carol's age in 6 years. Since we have used  $(J + 6)$  to represent Janet's age in 6 years, and  $(C + 6)$  to represent Carol's age in 6 years, we can translate the statement as follows:  $J + 6 = (1/2)(C + 6)$ .

Now, we can substitute the expression for  $C$  ( $C = J + 25$ ) derived from the first equation into the second equation (note: we choose to substitute for  $C$  and solve for  $J$  because the question asks us for Janet's age 5 years ago):

$$\begin{aligned} J + 6 &= (1/2)(J + 25 + 6) \\ J + 6 &= (1/2)(J + 31) \\ 2J + 12 &= J + 31 \\ J &= 19 \end{aligned}$$

If Janet is now 19 years old, she was 14 years old 5 years ago.

The correct answer is B.

4.

Since this problem includes variables in both the question and the answer choices, we can try solving by plugging in smart numbers. For  $x$ , we want to choose a multiple of 2 because we will have to take  $x/2$  later. Let's say that ACME produces 4 brooms per month from January to April, so  $x = 4$ . The total number of brooms produced was (4 brooms  $\times$  4 months), or 16 brooms.

ACME sold  $x/2$  brooms per month, or 2 brooms per month (because we chose  $x = 4$ ). Now we need to start figuring out the storage costs from May 2<sup>nd</sup> to December 31<sup>st</sup>. Since ACME sold 2 brooms on May 1<sup>st</sup>, it needed to store 14 brooms that month, at a cost of \$14. Following the same logic, we see that ACME sold another two brooms June 1<sup>st</sup> and stored 12 brooms, which cost the company \$12. We now see that the July storage costs were \$10, August were \$8, September \$6, October \$4, November \$2,

and for December there were no storage costs since the last 2 brooms were sold on December 1<sup>st</sup>.

So ACME's total storage costs were  $14 + 12 + 10 + 8 + 6 + 4 + 2 = \$56$ . Now we just need to find the answer choice that gives us \$56 when we plug in the same value,  $x = 4$ , that we used in the question. Since  $14 \times 4 = 56$ ,  $\$14x$  must be the correct value. The correct answer is E.

While plugging in smart numbers is the *preferred* method for VIC problems such as this one, it is not the only method. Below is an alternative, algebraic method for solving this problem:

ACME accumulated an inventory of  $4x$  brooms during its four-month production period. If it sold  $0.5x$  brooms on May 1<sup>st</sup>, then it paid storage for  $3.5x$  brooms in May, or  $\$3.5x$ . Again, if ACME sold  $0.5x$  brooms on June 1<sup>st</sup>, it paid storage for  $3x$  brooms in June, or  $\$3x$ . The first row of the table below shows the amount of money spent per month on storage. Notice that since ACME liquidated its stock on December 1<sup>st</sup>, it paid zero dollars for storage in December.

MAY	JUN	JUL	AUG	SEP	OCT	NOV
$\$3.5x$	$\$3x$	$\$2.5x$	$\$2x$	$\$1.5x$	$\$1x$	$\$0.5x$

If we add up these costs, we see that ACME paid  $\$14x$  for storage.

5.

The bus will carry its greatest passenger load when  $P$  is at its maximum value. If  $P = -2(S - 4)^2 + 32$ , the maximum value of  $P$  is 32 because  $(S - 4)^2$  will never be negative, so the expression  $-2(S - 4)^2$  will never be positive. The maximum value for  $P$  will occur when  $-2(S - 4)^2 = 0$ , i.e. when  $S = 4$ .

The question asks for the number of passengers two stops after the bus reaches its greatest passenger load, i.e. after 6 stops ( $S = 6$ ).

$$P = -2(6 - 4)^2 + 32$$

$$P = -2(2)^2 + 32$$

$$P = -8 + 32$$

$$P = 24$$

The correct answer is C.

Alternatively, the maximum value for  $P$  can be found by building a table, as follows:

$S$	$P$
0	0
1	14
2	24
3	30
4	32
5	30
6	24

The maximum value for  $P$  occurs when  $S = 4$ . Thus, two stops later at  $S = 6$ ,  $P = 24$ .

Answer choice C is correct.

6. John was 27 when he married Betty, and since they just celebrated their fifth wedding anniversary, he is now 32.

Since Betty's age now is  $7/8$  of John's, her current age is  $(7/8) \times 32$ , which equals 28.

The correct answer is C.

7. Joe uses  $1/4$  of 360, or 90 gallons, during the first week. He has 270 gallons remaining ( $360 - 90 = 270$ ).

During the second week, Joe uses  $1/5$  of the remaining 270 gallons, which is 54 gallons.

Therefore, Joe has used 144 gallons of paint by the end of the second week ( $90 + 54 = 144$ ).

The correct answer is B.

8. One way to do this problem is to recognize that the star earned \$8M more ( $\$32M - \$24M = \$8M$ ) when her film grossed \$40M more ( $\$100M - \$60M = \$40M$ ). She wants to earn \$40M on her next film, or \$8M more than she earned on the more lucrative of her other two films. Thus, her next film would need to gross \$40M more than \$100M, or \$140M.

Alternatively, we can solve this problem using algebra. The star's salary consists of a fixed amount and a variable amount, which is dependent on the gross revenue of the film. We know what she earned for two films, so we can set up two equations, where  $f$  is her fixed salary and  $p$  is her portion of the gross, expressed as a decimal:

She earned \$32 million on a film that grossed \$100 million:  $\$32M = f + p(\$100M)$   
She earned \$24 million on a film that grossed \$60 million:  $\$24M = f + p(\$60M)$

We can solve for  $p$  by subtracting the second equation from the first:

$$\begin{array}{r} \$32M = f + p(\$100M) \\ - [\$24M = f + p(\$60M)] \\ \hline \$8M = p(\$40M) \\ 0.2 = p \end{array}$$

We can now plug in 0.2 for  $p$  in either of the original equations to solve for  $f$ :

$$\begin{array}{l} \$32M = f + 0.2(\$100M) \\ \$32M = f + \$20M \\ \$12M = f \end{array}$$

Now that we know her fixed salary and the percentage of the gross earnings she receives, we can rewrite the formula for her total earnings as:

$$\text{Total earnings} = \$12M + 0.2(\text{gross})$$

Finally, we just need to figure out how much gross revenue her next film needs to generate in order for her earnings to be \$40 million:

$$\begin{array}{l} \$40M = \$12M + 0.2(\text{gross}) \\ \$28M = 0.2(\text{gross}) \\ \$28M/0.2 = \$140M = \text{gross} \end{array}$$

The correct answer is D.

9. I. UNCERTAIN: It depends on how many bicycles Norman sold.

For example, if  $x = 4$ , then Norman earned \$44 [= \$20 + (4 × \$6)] last week. In order to double his earnings, he would have to sell a minimum of 9 bicycles this week ( $y = 9$ ), making \$92 [= \$20 + (6 × \$6) + (3 × \$12)]. In that case,  $y > 2x$ .

However, if  $x = 6$  and  $y = 11$ , then Norman would have earned \$56 [= \$20 + (6 × \$6)] last week and \$116 [= \$20 + (6 × \$6) + (5 × \$12)] this week. In that case,  $\$116 > 2 \times \$56$ , yet  $y < 2x$ .

So, it is possible for Norman to more than double his earnings without selling twice as many bicycles.

II. TRUE: In order to earn more money this week, Norman must sell more bicycles.

III. TRUE: If Norman did not sell any bicycles at all last week ( $x = 0$ ), then he would have earned the minimum fixed salary of \$20. So he must have earned at least \$40 this week. If  $y = 3$ , then Norman earned \$38 [= \$20 + (3 × \$6)] this week. If  $y = 4$ , then Norman earned \$44 [= \$20 + (4 × \$6)] this week. Therefore, Norman must have sold at least 4 bicycles this week, which can be expressed  $y > 3$ .

The correct answer is D.

10. In order to determine the greatest number of points that an individual player might have scored, assume that 11 of the 12 players scored 7 points, the minimum possible. The 11 low scorers would therefore account for  $7(11) = 77$  points out of 100. The number of points scored by the twelfth player in this scenario would be  $100 - 77 = 23$ .

The correct answer is E.

11. Since we are not given any actual spending limits, we can pick numbers. In problems involving fractions, it is best to pick numbers that are multiples of the denominators.

We can set the spending limit for the gold account at \$15, and for the platinum card at \$30. In this case, Sally is carrying a balance of \$5 (which is  $1/3$  of \$15) on her gold card, and a balance of \$6 ( $1/5$  of \$30) on her platinum card. If she transfers the balance from her gold card to her platinum card, the platinum card will have a balance of \$11. That means that \$19 out of her \$30 spending limit would remain unspent.

Alternatively, we can solve this algebraically by using the variable  $x$  to represent the spending limit on her platinum card:

$$\begin{aligned}(1/5)x + (1/3)(1/2)x &= \\(1/5)x + (1/6)x &= \\(6/30)x + (5/30)x &= \\(11/30)x &\end{aligned}$$

This leaves  $19/30$  of her spending limit untouched.

The correct answer is D.

12. This fraction problem contains an "unspecified" total (the  $x$  liters of water in the lake). Pick an easy "smart" number to make this problem easier. Usually, the smart number is the lowest common denominator of all the fractions in the problem. However, if you pick 28, you will quickly see that this yields some unwieldy computation.

The easiest number to work with in this problem is the number 4. Let's say there are 4 liters of water originally in the lake. The question then becomes: During which year is the lake reduced to *less than 1 liter* of water?

At the end of 2076, there are  $4 \times (5/7)$  or  $20/7$  liters of water in the lake. This is not less than 1.

At the end of 2077, there are  $(20/7) \times (5/7)$  or  $100/49$  liters of water in the lake. This is not less than 1.

At the end of 2078, there are  $(100/49) \times (5/7)$  or  $500/343$  liters of water in the lake. This is not less than 1.

At the end of 2079, there are  $(500/343) \times (5/7)$  or  $2500/2401$  liters of water in the lake. This is not less than 1.

At the end of 2080, there are  $(2500/2401) \times (5/7)$  or  $12500/16807$  liters of water in the lake. **This is less than 1.**

Notice that picking the number 4 is essential to minimizing the computation involved, since it is very easy to see when a fraction falls below 1 (when the numerator becomes less than the denominator.) The only moderately difficult computation involved is multiplying the denominator by 7 for each new year.

The correct answer is D.

13.

This fraction problem contains an unspecified total (the number of married couples) and is most easily solved by a picking a "smart" number for that total. The smart number is the least common denominator of all the fractions in the problem. In this case, the smart number is 20.

Let's say there are 20 married couples.

15 couples ( $3/4$  of the total) have more than one child.

8 couples ( $2/5$  of the total) have more than three children.

This means that  $15 - 8 = 7$  couples have either 2 or 3 children. Thus  $7/20$  of the married couples have either 2 or 3 children.

The correct answer is C.

14.

We can back solve this question by using the answer choices. Let's first check to make sure that each of the 5 possible prices for one candy can be paid using exactly 4 coins:

$$8 = 5+1+1+1$$

$$13 = 10+1+1+1$$

$$40 = 10+10+10+10$$

$$53 = 50+1+1+1$$

$$66 = 50+10+5+1$$

So far we can't make any eliminations. Now let's check two pieces of candy:

$$16 = 5 + 5 + 5 + 1$$

$$26 = 10 + 10 + 5 + 1$$

$$80 = 25 + 25 + 25 + 5$$

$$106 = 50 + 50 + 5 + 1$$

$$132 = 50 + 50 + 25 + 5 + 1 + 1$$

We can eliminate answer choice E here. Now three pieces of candy:

$$24 = 10 + 10 + 1 + 1 + 1 + 1$$

$$39 = 25 + 10 + 1 + 1 + 1 + 1$$

$$120 = 50 + 50 + 10 + 10$$

$$159 = 50 + 50 + 50 + 5 + 1 + 1 + 1 + 1.$$

We can eliminate answer choices A, B and D.

Notice that at a price of 40¢, Billy can buy four and five candies with exactly 4 coins as well:

$$160 = 50 + 50 + 50 + 10$$

$$200 = 50 + 50 + 50 + 50$$

This problem could also have been solved using divisibility and remainders. Notice that all of the coins are multiples of 5 except pennies. In order to be able to pay for a certain number of candies with exactly four coins, the total price of the candies cannot be a value that can be expressed as  $5x + 4$ , where  $x$  is a positive integer. In other words, the total price cannot be a number that has a remainder of 4 when divided by 5. Why? The remainder of 4 would alone require 4 pennies.

We can look at the answer choices now just focusing on the remainder when each price and its multiples are divided by 5:

Price per candy	Remainder when price for 1 candy is divided by 5	Remainder when price for 2 candies is divided by 5	Remainder when price for 3 candies is divided by 5	Remainder when price for 4 candies is divided by 5
8	3	1	4	1
13	3	1	4	2
40	0	0	0	0
53	3	1	4	2
66	1	2	3	4

The only price for which none of its multiples have a remainder of 4 when divided by 5 is 40¢.

Notice that not having a remainder of 4 does *not guarantee* that exactly four coins can be used; however, having a remainder of 4 does guarantee that exactly four coins cannot be used!

The correct answer is C.

**15.**

From the question we know that 40 percent of the violet/green mix is blue pigment. We also know that 30 percent of the violet paint and 50 percent of the green paint is blue pigment. Since the blue pigment in the violet/green mix is the same blue pigment in the original violet and green paints, we can construct the following equation:

$$.3v + .5g = .4(v + g)$$

$$.3v + .5g = .4v + .4g$$

$$.1g = .1v$$

$$g = v$$

Therefore, the amount of violet paint is equal to the amount of green paint in the brown mixture, each contributing 50 percent of the total. Since the red pigment represents 70 percent of the weight of the violet paint, it must account for 70 percent of 50 percent of the weight of the brown mix. This represents  $(.7)(.5) = .35$ , or 35% of the total weight of the brown mix. Since we have 10 grams of the brown paint, the red pigment must account for  $(.35)(10) = 3.5$  grams of the brown paint.

There is an alternative way to come up with the conclusion that there must be equal amounts of green and violet paints in the mix. Since there is blue paint in both the violet and green paints, when we combine the two paints, the percentage of blue paint in the mix will be a *weighted average* of the percentages of blue in the violet paint and the percentage of blue in the green paint. For example, if there is twice as much violet as green in the brown mix, the percentage of blue in the violet will get double weighted. From looking at the numbers, however, 40% is exactly the simple average of the 30% blue in violet and the 50% blue in green. This means that there must be an equal amount of both paints in the mix.

Since there are equal amounts of violet and green paint in the 10 grams of brown mixture, there must be 5 grams of each. The violet paint is 70% red, so there must be  $(.7)(5) = 3.5$  grams of red paint in the mix.

The correct answer is B.

**16.**

We can find a ratio between the rates of increase and decrease for the corn and wheat:

$$\frac{\text{rate of corn price increase}}{\text{rate of wheat price decrease}} = \frac{5x}{x(\sqrt{2} - 1)}$$

To get rid of the radical sign in the denominator, we can multiply top and bottom by  $\sqrt{2} + 1$  and simplify:

$$\begin{aligned} \frac{5x}{x(\sqrt{2}-1)} \times \frac{\sqrt{2}+1}{\sqrt{2}+1} &\rightarrow \\ \frac{5\sqrt{2}(x) + 5x}{x(2-1)} &\rightarrow \\ \frac{x(5\sqrt{2}+5)}{x(2-1)} &\rightarrow \\ \frac{5\sqrt{2}+5}{1} \end{aligned}$$

This ratio indicates that for every cent that the price of wheat decreases, the price of corn increases by  $5\sqrt{2} + 5$  cents. So if the price of wheat decreases by  $x$  cents, the price of corn will increase by  $(5\sqrt{2} + 5)x$  cents.

Since the difference in price between a peck of wheat and a bushel of corn is currently \$2.60 or 260 cents, the amount by which the price of corn increases plus the amount by which the price of wheat decreases must equal 260 cents. We can express this as an equation:

$$\text{Amount Corn Increases} + \text{Amount Wheat Decreases} = 260$$

We can then rewrite this word equation using variables. Let  $c$  be the decrease in the price of wheat in cents:

$$\begin{aligned} (5\sqrt{2} + 5)c + c &= 260 \rightarrow \\ (5\sqrt{2})c + 5c + c &= 260 \rightarrow \\ (5\sqrt{2})c + 6c &= 260 \rightarrow \\ (5(1.4))c + 6c &= 260 \rightarrow \\ 7c + 6c &= 260 \rightarrow \\ 13c &= 260 \rightarrow \\ c &= 20 \end{aligned}$$

Notice that the radical 2 was replaced with its approximate numerical value of 1.4 because the question asks for the approximate price. We need not be exact in this particular instance.

If  $c = 20$ , we know that the price of a peck of wheat had decreased by 20 cents when it reached the same level as the increased price of a bushel of corn. Since the original price of a peck of wheat was \$5.80, its decreased price is  $\$5.80 - \$0.20 = \$5.60$ .

(By the same token, since  $c = 20$ , the price of a bushel of corn had increased by  $20(5\sqrt{2} + 5)$  cents when it reached the same level as the decreased price of a peck of wheat. This is equivalent to an increase of approximately 240 cents. Thus the

increased price of a bushel of corn =  $\$3.20 + \$2.40 = \$5.60$ .)

The correct answer is E.

17.

Let  $s$  represent the number of science majors,  $m$  represent the number of math majors,  $h$  represent the number of history majors, and  $l$  represent the number of linguistics majors.

We can set up the following equations:

$$s = (1/3)h$$

$$m = (2/3)h$$

$$s + m + h + l = 2000$$

We can substitute and isolate the number of linguistics majors.

$$(1/3)h + (2/3)h + h + l = 2000$$

$$2h + l = 2000$$

$$l = 2000 - 2h$$

We can rephrase the question: "How many students major in history?"

(1) SUFFICIENT: If  $l = m$ , and  $m = (2/3)h$ , we can solve for  $h$ :

$$(1/3)h + (2/3)h + h + l = 2000$$

$$(1/3)h + (2/3)h + h + (2/3)h = 2000$$

$$(8/3)h = 2000$$

$$h = 2000(3/8)$$

$$h = 750$$

If  $h = 750$ ,  $l = (2/3)h = 500$ .

(2) SUFFICIENT: If  $m = s + 250$ , and  $m = (2/3)h$  and  $s = (1/3)h$ , we can substitute and solve for  $h$ :

$$(2/3)h = (1/3)h + 250$$

$$(1/3)h = 250$$

$$h = 750$$

If  $h = 750$ ,  $l = 2000 - 2(750) = 500$ .

The correct answer is D.

**18.**

We can think of the liquids in the red bucket as liquids A, B, C and E, where E represents *the totality of every other kind of liquid that is not A, B, or C*. In order to determine the percentage of E contained in the red bucket, we will need to determine the total amount of A + B + C and the total amount of E.

*It is TEMPTING (but incorrect) to use the following logic with the information given in Statement (1).*

Statement (1) tells us that the total amount of liquids A, B, and C now in the red bucket is 1.25 times the total amount of liquids A and B initially contained in the green bucket.

Let's begin by assuming that, initially, there are 10 ml of liquid A in the green bucket. Using the percentages given in the problem we can now determine that the composition of the green bucket was as follows:

$$10\% \text{ A} = 10 \text{ ml}$$

$$10\% \text{ B} = 10 \text{ ml}$$

$$80\% \text{ E} = 80 \text{ ml}$$

Since there were 20 total ml of A and B in the green bucket, we know from statement (1) that there must be 25 ml of A + B + C now in the red bucket (since 25 is 1.25 times 20).

From this we can deduce that, there must have been 5 ml of C in the blue bucket. We can use the percentages given in the problem to determine the exact initial composition of the blue bucket:

$$10\% \text{ C} = 5 \text{ ml}$$

$$90\% \text{ E} = 45 \text{ ml}$$

Since the liquid in the red bucket is simply the totality of all the liquids in the green bucket plus all the liquids in the blue bucket, we can use this information to determine the total amount of A + B + C (25 ml) and the total amount of E (80 + 45 = 125 ml) in the red bucket. Thus, the percentage of liquid now in the red bucket that is NOT A, B, or C is equal to  $125/150 = 83 \frac{1}{3}$  percent.

This ratio (or percentage) will always remain the same no matter what initial amount we choose for liquid A in the green bucket. This is because the relative percentages are fixed. We can generalize that given an initial amount  $x$  for liquid A in the green bucket, we know that the amount of liquid B in the green bucket must also be  $x$  and that the amount of E in the green bucket must be  $8x$ . We also know that the amount of liquid C in the blue bucket must be  $.5x$ , which means that the amount of E in the blue bucket must be  $4.5x$ .

Thus the total amount of A + B + C in the red bucket is  $x + x + .5x = 2.5x$  and the total amount of liquid E in the red bucket is  $8x + 4.5x = 12.5x$ . Thus the percentage of liquid now in the red bucket that is NOT A, B, or C is equal to  $12.5x/15x$  or  $83 \frac{1}{3}$  percent.

*However, the above logic is FLAWED because it assumes that the green bucket does not contain liquid C and that the blue bucket does not contain liquids A or B.*

In other words, the above logic assumes that knowing that there are  $x$  ml of A in the green bucket implies that there are  $8x$  ml of E in the green bucket. Remember, however, that E is defined as *the totality of every liquid that is NOT A, B, or C!* While the problem gives us information about the percentages of A and B contained in the green bucket, it does not tell us anything about the percentage of C contained in the green bucket and we cannot just assume that this is 0. If the percentage of C in the green bucket is not 0, then this will change the percentage of E in the green bucket as well as changing the relative amount of liquid C in the blue bucket.

For example, let's say that the green bucket contains 10 ml of liquids A and B but also contains 3 ml of liquid C. Take a look at how this changes the logic:

Green bucket:

10% A = 10 ml

10% B = 10 ml

3% C = 3 ml

77% E = 77 ml

Since there are 20 total ml of A and B in the green bucket, we know from statement (1) that there must be 25 ml of A + B + C in the red bucket (since 25 is 1.25 times 20).

Since the green bucket already contributes 23 ml of this total, we know that there must be 2 total ml of liquids A, B and C in the blue bucket. If the blue bucket does not contain liquids A or B (which we cannot necessarily assume), then the composition of the blue bucket would be the following:

10% C = 2 ml

90% E = 18 ml

Note, however, that if the blue bucket does contain some of liquids A or B, then the composition of the blue bucket might also be the following:

10% C = 1 ml

10% A = 1 ml

80% E = 8 ml

Notice that it is impossible to ascertain the exact amount of E in the red bucket - since this amount will change depending on whether the green bucket contains liquid C and/or the blue bucket contains liquids A or B.

Thus statement (1) by itself is NOT sufficient to answer this question.

Statement (2) tells us that the green and blue buckets did not contain any of the same liquids. As such, we know that the green bucket did not contain liquid C and that the blue bucket did not contain liquids A or B. On its own, this does not help us to answer the question. However, taking Statement (2) together with Statement (1), we can definitively answer the question.

The correct answer is C: BOTH statements TOGETHER are sufficient, but NEITHER statement ALONE is sufficient.

19.

The question stem tells us that Bill has a stack of \$1, \$5, and \$10 bills in the ratio of 10 : 5 : 1 respectively. We're trying to find the number of \$10 bills.

(1) INSUFFICIENT: Since the ratio of the number of \$1 bills to \$10 bills is 10 : 1, the dollar value of the \$1 and \$10 bills must be equal. Therefore statement (1) gives us no new information, and we cannot find the number of \$10 bills.

(2) SUFFICIENT: The problem states that the number of \$1, \$5, and \$10 bills is in the ratio of

10 : 5 : 1, so let's use an unknown multiplier  $x$  to solve the problem.

	\$1 bills	\$5 bills	\$10 bills	Total
Number	$10x$	$5x$	$1x$	$16x$
Value	$\$10x$	$\$25x$	$\$10x$	$\$45x$

Using  $x$ , we can see that there are  $10x$  \$1 bills with a value of  $\$10x$ . Furthermore, there are  $5x$  \$5 bills with a value of  $\$25x$ . Finally, there are  $1x$  \$10 bills with a value of  $\$10x$ . Statement (2) says that the total amount he has is  $\$225$ , so we can set up an equation as follows:

$$\$10x + \$25x + \$10x = \$225$$

$$\$45x = \$225$$

$$x = 5$$

Since there are  $1x$  \$10 bills this means that there are 5 \$10 bills.

The correct answer is B.

**20.**

Let number of rows is  $a$ , number of the chairs in a row is  $b$ .

So,  $b-a=1$

From 1,  $ab=72$ ,  $a=8$ ,  $b=9$ , sufficient alone.

From 2,  $2b-1=17$ ,  $b=9$ , sufficient alone.

Answer is D.

21.

Let attend fee be  $x$ , number of person be  $y$ :

$$\text{Form 1, } (x-0.75)(y+100)=xy \text{ ---- } 100x-0.75y-75=0$$

$$\text{From 2, } (x+1.5)(y-100)=xy \text{ ---- } 100x+1.5y-150=0$$

Combine 1 and 2, we can get specific value of  $x$  and  $y$ .  
Answer is C

**22.**

1) is sufficient.

2). No two members sold same number of tickets; the least numbers of the tickets they sold would be 0, 1, 2.

Answer is D

**23.**

$$c=kx+t$$

In last month,  $\text{cost}=1000k+t$ ;  $\text{profit}=1000(k+60) - (1000k+t) = 60000-t$ , so, we need to solve  $t$ .

From 1,  $150000=1000*(k+60)$ , there is no information about  $t$ .

From 2,  $(1000k+t)-(500k+t)=45000$ , still cannot solve out  $t$ .

Answer is E

**24.**

In the origin plan, each one should pay  $X/T$ .

Actually, each of the remaining coworkers paid  $X/(T-S)$ .

Then,  $X/(T-S) - X/T = S*X / T(T-S)$

**25.**

It might be tempting to think that either statement is sufficient to answer this question. After all, pouring water from the larger container to the smaller container will leave exactly 2 gallons of water in the larger container. Repeating this operation twice will yield 4 gallons of water.

The problem is - where would these 4 gallons of water accumulate? We will need to use one of the containers. However, neither statement alone tells us whether one of the containers will hold 4 gallons of water.

On the other hand, statements (1) and (2) taken together ensure that the first container can hold at least 4 gallons of water. We know this because (from statement 1) the first container holds 2 gallons more than the second container, which (from statement 2) holds 2 gallons more than the third container, which must have a capacity greater than 0.

Since we know that the first container has a capacity of at least 4 gallons, there are several ways of measuring out this exact amount.

One method is as follows: Completely fill the first container with water. Then pour out just enough water from the first container to fill the third container to the brim. Now, 4 gallons of water remain in the first container.

Alternatively: Fill the first container to the brim. Pour out just enough water from the first container to fill the second container to the brim. There are now 2 gallons of water in the first container. Now pour water from the second container to fill the third container to the brim. There are now 2 gallons of water in the second container. Finally, pour all the water from the second container into the first container. There are now 4 gallons of water in the first container.

**26.**

Begin by rephrasing, or simplifying, the original question. Since the rules of the game involve the *negative* of the sum of two dice, one way of restating this problem is that whoever gets the higher sum *LOSES* the game. Thinking about the sum of the two dice is easier than thinking about the *negative* of the sum of the two dice. Thus, let's rephrase the question as: Who *lost* the game? (Knowing this will obviously allow us to answer the original question, who *won* the game.)

Statement (1) gives us information about the first of Nina's dice, but it does not tell us anything about the second. Consider the following two possibilities:

	Nina's First Roll	Nina's Second Roll	Teri's Sum	Higher Sum = Loser
CASE ONE	<b>3</b>	5	<b>-1</b>	Nina
CASE TWO	<b>3</b>	-5	<b>-1</b>	Teri

Notice that in both cases, Nina's first roll is greater than Teri's Sum. However, in Case One Nina loses, but in Case Two Teri loses. Thus, this information is not sufficient to answer the question.

Statement (2) gives us information about the second of Nina's dice, but it does not tell us anything about the first. Using the same logic as for the previous statement, this is not sufficient on its own to answer the question.

Combining the information contained in both statements, one may be tempted to conclude that Nina's sum must be higher than Teri's sum. However, one must test scenarios involving both positive and negative rolls. Consider the following two possibilities.

	Nina's First Roll	Nina's Second Roll	Teri's Sum	Higher Sum = Loser
CASE ONE	<b>3</b>	<b>4</b>	<b>-5</b>	Nina
CASE TWO	<b>-3</b>	<b>-4</b>	<b>-5</b>	Teri

Notice that in both cases, Nina's first roll is greater than Teri's Sum and Nina's second roll is greater than Teri's sum. However, in Case One Nina loses, but in Case Two Teri loses. Thus, this information is not sufficient to answer the question.

The correct answer is E: Statements (1) and (2) TOGETHER are NOT sufficient.

27.

The question gives a function with two unknown constants and two data points. In order to solve for the position of the object after 4 seconds, we need to first solve for the constants  $r$  and  $b$ . We can do this by creating two equations from the two data points given:

$$\begin{aligned} p(2) &= 41 = r(2) - 5(2)^2 + b \\ 41 &= 2r - 20 + b \\ 61 &= 2r + b \end{aligned}$$

$$\begin{aligned} p(5) &= 26 = r(5) - 5(5)^2 + b \\ 26 &= 5r - 125 + b \\ 151 &= 5r + b \end{aligned}$$

We can now solve these equations for  $r$  and  $b$  using substitution:

$$\begin{aligned} 61 &= 2r + b \\ (61 - 2r) &= b \end{aligned}$$

$$\begin{aligned} 151 &= 5r + b \\ 151 &= 5r + (61 - 2r) \\ 151 &= 3r + 61 \\ 90 &= 3r \end{aligned}$$

$$r = 30$$

Substituting back in, we can find  $b$ :

$$61 = 2r + b$$

$$61 = 2(30) + b$$

$$b = 1$$

So, we can rewrite the original function and plug in  $t = 4$  to find our answer:

$$p(t) = 30t - 5t^2 + 1$$

$$p(4) = 30(4) - 5(4)^2 + 1$$

$$p(4) = 120 - 80 + 1$$

$$p(4) = 41$$

The correct answer is D.

28.

Let us call the Trussian's current age  $a$ . Therefore the Trussian's current weight is  $\sqrt{a}$ .

Seventeen years after he is twice as old as he is now, the Trussian's age will be  $2a + 17$  and his weight will therefore be  $\sqrt{2a + 17}$ . We are told that the Trussian's current weight,  $\sqrt{a}$ , is three keils less than his future weight,  $\sqrt{2a + 17}$ . Therefore,  $\sqrt{a} + 3 = \sqrt{2a + 17}$ . We can solve the equation as follows:

$$\sqrt{a} + 3 = \sqrt{2a + 17}$$

$$(\sqrt{a} + 3)^2 = (\sqrt{2a + 17})^2$$

$$a + 6\sqrt{a} + 9 = 2a + 17$$

$$6\sqrt{a} = a + 8$$

$$(6\sqrt{a})^2 = (a + 8)^2$$

$$36a = a^2 + 16a + 64$$

$$a^2 - 20a + 64 = 0$$

$$(a - 16)(a - 4) = 0$$

$a = 16$  or  $4$ . However, we are told that the Trussian is a teenager so he must be 16 years old. The correct answer is C.

29.

This problem is easier to think about with real values.

Let's assume that there are 2 high level officials. This means that each of these 2 high level officials supervises 4 (or  $x^2$ ) mid-level officials, and that each of these 4 mid-level officials supervises 8 (or  $x^3$ ) low-level officials.

It is possible that the supervisors do not share any subordinates. If this is the case, then, given 2 high level officials, there must be  $2(4) = 8$  mid-level officials, and  $8(8) = 64$  low-level officials.

Alternatively, it is possible that the supervisors share all or some subordinates. In other words, given 2 high level officials, it is possible that there are as few as 4 mid-level officials (as each of the 2 high-level officials supervise the same 4 mid-level officials) and as few as 8 low-level officials (as each of the 4 mid-level officials supervise the same 8 low-level officials).

Statement (1) tells us that there are fewer than 60 low-level officials. This alone does not allow us to determine how many high-level officials there are. For example, there might be 2 high level officials, who each supervise the same 4 mid-level officials, who, in turn, each supervise the same 8 low-level officials. Alternatively, there might be 3 high-level officials, who each supervise the same 9 mid-level officials, who, in turn, each supervise the same 27 low-level officials.

Statement (2) tells us that no official is supervised by more than one person, which means that supervisors do not share any subordinates. Alone, this does not tell us anything about the number of high-level officials.

Combining statements 1 and 2, we can test out different possibilities.

If  $x = 1$ , there is 1 high-level official, who supervises 1 mid-level official ( $1^2 = 1$ ), who, in turn, supervises 1 low-level official ( $1^3 = 1$ ).

If  $x = 2$ , there are 2 high-level officials, who each supervise a unique group of 4 mid-level officials, yielding 8 mid-level officials in total. Each of these 8 mid-level officials supervise a unique group of 8 low-level officials, yielding 64 low-level officials in total. However, this cannot be the case since we are told that there are *fewer* than 60 low-level officials.

Therefore, based on both statements taken together, there must be only 1 high-level official. The correct answer is C: BOTH statements TOGETHER are sufficient, but NEITHER statement ALONE is sufficient.

30.

Use algebra to solve this problem as follows:

Let the  $x$  = the number of donuts Jim originally ordered. Since he paid \$15 for these donuts, the price per donut for his original order is  $\$15/x$ .

When he leaves, Jim receives 3 free donuts changing the price per donut to  $\$15/(x + 3)$ . In addition, we know that the price per dozen donuts was \$2 per dozen cheaper when he leaves, equivalent to a per donut savings of  $\$2/12 = 1/6$  dollars.

Using this information, we can set up an equation that states that the original price per donut less  $1/6$  of a dollar is equal to the price per donut after the addition of 3 donuts:

$$\frac{15}{x} - \frac{1}{6} = \frac{15}{x+3}$$

We can now solve for  $x$  as follows:

$$\frac{15}{x} - \frac{1}{6} = \frac{15}{x+3}$$

$$\frac{90 - x}{6x} = \frac{15}{x+3}$$

$$(90 - x)(x + 3) = 90x$$

$$-x^2 - 3x + 90x + 270 = 90x$$

$$0 = x^2 + 3x - 270$$

$$0 = (x - 15)(x + 18)$$

$$x = \{15, -18\}$$

The only positive solution of  $x$  is 15. Hence, Jim left the donut shop with  $x + 3 = 18$  donuts. The correct answer is A.

**31.**

Each year, the age of the boy increases by 1. Each year, the sum of the ages of the two girls increases by 2 (as each girl gets older by one year, and there are two of them).

Let's say that the age of the boy today is equal to  $x$ , while the combined ages of the girls today is equal to  $y$ .

Then, next year the figures will be  $x + 1$  and  $y + 2$ , respectively. The problem states that these two figures will be equal, which yields the following equation:

$$x + 1 = y + 2 \text{ which can be simplified to } \mathbf{x = y + 1}$$

(This is consistent with the fact that the sum of the ages of the two girls today is smaller than the age of the boy today.)

Three years from now, the combined age of the girls will be  $y + 3(2) = y + 6$ . Three years from now, the boy's age will be  $x + 3$ . Using the fact (from above) that  $x = y + 1$ , the boy's age three years from now can be written as  $x + 3 = (y + 1) + 3 = y + 4$ .

The problem asks for the difference between the age of the boy three years from today and the combined ages of the girls three years from today. This difference equals  $y + 4 - (y + 6) = -2$ . The correct answer is D.

Plug in real numbers to see if this makes sense.

Let the girls be 4 and 6 in age. The sum of their ages today is 10. The boy's age today is then  $(10 + 1) = 11$ . Three years from today, the girls will be 7 and 9 respectively, so their combined age will be 16. Three years from today, the boy will be 14.

Be careful: The question asks for the difference between the boy's age and the sum of the girls ages three years from today. Which one will be younger? The boy. So the difference between the boy's age and the combined age of the girls will be a negative value:  $14 - 16 = -2$ .

**32.**

Use a chart to keep track of the ages in this problem:

	$x$ years ago	NOW	in $x$ years
Corey	$C - x$	$C$	$C + x$
Tania	$T - x$	$T$	$T + x$

Then write algebraic expressions to represent the information given in the problem:

$x$ years ago, Cory was one fifth as old as Tania $5(C - x) = T - x$ $5C - 5x = T - x$ $5C - T = 4x$	In $x$ years, Tania will be twice as old as Cory $2(C + x) = T + x$ $2C + 2x = T + x$ $T - 2C = x$
---	---

Substitute  $T - 2C$  in for  $x$  in the first equation and solve:

$$\begin{aligned} 5C - T &= 4(T - 2C) \\ 5C - T &= 4T - 8C \\ 13C &= 5T \\ \frac{C}{T} &= \frac{5}{13} \end{aligned}$$

The correct answer is C.

33.

The question does not ask for the actual number of years ago that animal  $z$  became extinct. Instead it asks for  $t$ , the number of years scientists predicted it would take for animal  $z$  to become extinct.

(1) INSUFFICIENT: This tells us that animal  $z$  became extinct 4 years ago but it does not provide information about  $t$ .

(2) INSUFFICIENT: This provides a relationship between the predicted time of extinction time and the actual time of extinction but does not provide any actual values for either.

(1) AND (2) INSUFFICIENT: The easiest way to approach this problem is to imagine a time line from 0 to 10. The scientists made their prediction 10 years ago, or at 0 years.

From statement (1) we know that animal  $z$  became extinct 4 years ago, or at 6 years.

From statement (2) we know that if the scientists had extended their prediction by 3 years they would have been incorrect by 2 years. The key to this question is to realize that "incorrect by 2 years" could mean 2 years in either direction:  $6 + 2 = 8$  years or  $6 - 2 = 4$  years.

From here, we can write two simple equations:

$$\begin{array}{l} t + 3 = 8 \\ t = 5 \end{array} \quad \text{OR} \quad \begin{array}{l} t + 3 = 4 \\ t = 1 \end{array}$$

This gives us two different values for  $t$ , which means that (1) and (2) together are not sufficient to come up with one definitive value for  $t$ . The correct answer is E.

34.

To answer this question, we need to minimize the value of  $l = (7.5 - x)^4 + 8.97^{1.05}$ . Since we do not need to determine the actual minimum longevity, we do not need to find the value of the second component in our formula,  $8.97^{1.05}$ , which will remain constant for any level of  $x$ . Therefore, to minimize longevity, we need to minimize the value of the first component in our formula,

i.e.  $(7.5 - x)^4$ . Since we are raising the expression  $(7.5 - x)$  to an even exponent, 4, the value of

$(7.5 - x)^4$  will always be non-negative, i.e. positive or zero. Thus, to minimize this outcome, we need to find the value of  $x$  for which  $(7.5 - x)^4 = 0$ .

$$(7.5 - x)^4 = 0$$

$$7.5 - x = 0$$

$$x = 7.5$$

Therefore, the metal construction will have minimal longevity for the value of  $x = 7.5$ , i.e. when the density of the underlying material will be equal to 7.5 g/cm<sup>3</sup>.

The correct answer is C.

## Calculations, Exponents, Basic Algebra

### 1.

The first culprit in this expression is the radical in the denominator. Radicals in the denominator are dealt with by multiplying the fraction with an expression that is equal to 1 but contains a "canceling radical" in both the numerator and denominator.

For example,  $\frac{6}{\sqrt{3}}$  is simplified by multiplying by  $\frac{\sqrt{3}}{\sqrt{3}}$ .

In the case of a complex radical, such as  $5 + 2\sqrt{6}$ , we multiply by the conjugate,  $5 - 2\sqrt{6}$  as follows:

$$\begin{aligned} \sqrt{\frac{96}{5 + 2\sqrt{6}} \cdot \frac{(5 - 2\sqrt{6})}{(5 - 2\sqrt{6})}} &= \sqrt{\frac{96}{25 - 4(6)}} \\ &= \sqrt{\frac{96 + \frac{10 - 4\sqrt{6}}{1}}{1}} = \sqrt{96 + 10 - 4\sqrt{6}} \\ &= \sqrt{\sqrt{16 \times 6} + 10 - 4\sqrt{6}} = \sqrt{4\sqrt{6} + 10 - 4\sqrt{6}} = \sqrt{10} \end{aligned}$$

Simplifying radicals in the denominator with conjugate radical expressions is very useful on challenging GMAT radical questions.

The correct answer is C.

### 2.

The GMAT does not require you to know how to evaluate an integral **root** of any general integer, but you are expected to understand how to evaluate an integer raised to an integer **power**. Hence, you should immediately realize that there must be a way we can transform each of the expressions into an expression that we can evaluate.

The most obvious way to transform a root into a power is to raise it to a higher power. Since we are trying to compare the expressions, a reasonable transformation is to raise each of the expressions to the same power. What power should we use?

$$\left(\sqrt[m]{x}\right)^n = \left(x^{\frac{1}{m}}\right)^n = x^{\frac{n}{m}}$$

Since  $\left(\sqrt[m]{x}\right)^n = x^{\frac{n}{m}}$ , in order to get integral powers of  $x$  (i.e.,  $n/m$  is an integer) we should raise all of the roots to the Least Common Multiple of the  $m$ 's. We have roots of 3, 6, 10, and 15, so the LCM is equal to 30. Therefore, we should raise each of the expressions to the 30<sup>th</sup> power as follows:

$$\left(\sqrt[3]{2}\right)^{30} = 2^{10} = 1024$$

$$\left(\sqrt[6]{5}\right)^{30} = 5^5 = 3125$$

$$\left(\sqrt[10]{10}\right)^{30} = 10^3 = 1000$$

$$\left(\sqrt[15]{30}\right)^{30} = 30^2 = 900$$

Thus, the original expressions in increasing order are as follows:

$$\sqrt[15]{30} \quad \sqrt[10]{10} \quad \sqrt[3]{2} \quad \sqrt[6]{5}$$

3.

In order to rid the expression of square roots, let's first square the entire expression. We are allowed to do this as long as we remember to "unsquare" whatever solution we get at that end.

$$\sqrt{24 + 5\sqrt{23}} + \sqrt{24 - 5\sqrt{23}} \rightarrow \left( \sqrt{24 + 5\sqrt{23}} + \sqrt{24 - 5\sqrt{23}} \right)^2$$

Notice that the new expression is of the form  $(x + y)^2$  where

$$x = \sqrt{24 + 5\sqrt{23}} \quad \text{and} \quad y = \sqrt{24 - 5\sqrt{23}}$$

Recall that  $(x + y)^2 = x^2 + y^2 + 2xy$ . This is one of the GMAT's favorite expressions.

Returning to our expression:

$$x^2 = 24 + 5\sqrt{23}, \quad \text{while} \quad y^2 = 24 - 5\sqrt{23} \quad \text{and} \quad 2xy = 2\left(\sqrt{24 + 5\sqrt{23}}\right)\left(\sqrt{24 - 5\sqrt{23}}\right)$$

Notice that  $x^2 + y^2$  neatly simplifies to 48. This leaves only the  $2xy$  expression left to simplify.

In order to simplify  $2\left(\sqrt{24 + 5\sqrt{23}}\right)\left(\sqrt{24 - 5\sqrt{23}}\right)$ , recall that  $(\sqrt{a})(\sqrt{b}) = \sqrt{ab}$ .

$$\text{Thus,} \quad 2\left(\sqrt{24 + 5\sqrt{23}}\right)\left(\sqrt{24 - 5\sqrt{23}}\right) = 2\sqrt{(24 + 5\sqrt{23})(24 - 5\sqrt{23})}$$

Notice that the expression under the square root sign is of the form  $(x + y)(x - y)$ . And recall

that  $(x + y)(x - y) = x^2 - y^2$ . This is another one of the GMAT's favorite expressions.

Returning to our expression:

$$2\sqrt{(24 + 5\sqrt{23})(24 - 5\sqrt{23})} = 2\sqrt{24^2 - (5\sqrt{23})^2} = 2\sqrt{24^2 - (25)(23)} = 2\sqrt{576 - 575} = 2\sqrt{1} = 2$$

Finally then:  $x^2 + y^2 + 2xy = 48 + 2 = 50$ .

But now we must remember to "unsquare" (or take the square root of) our answer:

$$\sqrt{50} = \sqrt{25 \times 2} = 5\sqrt{2}$$

Therefore, the correct answer is D.

4. We can simplify the question as follows:

$$8^a(1/4)^b = ? \quad [\text{Break all non-primes down to primes.}]$$

$$(2^3)^a(2^{-2})^b = ? \quad [\text{Multiply exponents taken on the same base.}]$$

$$(2^{3a})(2^{-2b}) = ? \quad [\text{Add exponents since the two bases are equal.}]$$

$$2^{3a-2b} = ?$$

We can rephrase the question as "what is  $3a - 2b$ ?"

(1) SUFFICIENT:  $b = 1.5a$ , so  $2b = 3a$ . This means that  $3a - 2b = 0$ .

(2) INSUFFICIENT: This statement gives us no information about  $b$ .

The correct answer is A

5.

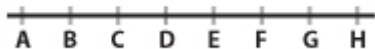

The distance from  $G$  to  $H$  is  $5^{13} - 5^{12}$ .

The distance between any two consecutive points is constant, so the distance from  $A$  to  $G$  will be 6 times the distance from  $G$  to  $H$  or  $6(5^{13} - 5^{12})$ .

The value of  $A$ , therefore, will be equal to the value of  $G$  minus the distance from  $A$  to  $G$ :

$$5^{12} - 6(5^{13} - 5^{12}) \longrightarrow 5^{12} - 6[5^{12}(5 - 1)] \longrightarrow 5^{12} - 6(5^{12})(4) \longrightarrow$$

$$5^{12}(1 - 24) \longrightarrow (-23)5^{12}.$$

The correct answer is B.

$$6. \quad (3^{5x} + 3^{5x} + 3^{5x})(4^{5x} + 4^{5x} + 4^{5x} + 4^{5x}) =$$

$$3^{5x}(1 + 1 + 1) \times 4^{5x}(1 + 1 + 1 + 1) =$$

$$3(3^{5x}) \times 4(4^{5x}) =$$

$$3^{5x+1} \times 4^{5x+1} =$$

$$(3 \times 4)^{5x+1} =$$

$$12^{5x+1}$$

Remember that when you multiply different bases raised to the SAME exponent, the product is simply the product of the bases raised to their common exponent.

The correct answer is A.

7.

First, let us simplify the exponential equation:

$$(2^a)(3^b)(5^c) = 12(2^k)(3^l)(5^m)$$

$$(2^a)(3^b)(5^c) = (3)(4)(2^k)(3^l)(5^m)$$

$$(2^a)(3^b)(5^c) = (3^1)(2^2)(2^k)(3^l)(5^m)$$

$$(2^a)(3^b)(5^c) = (2^{k+2})(3^{l+1})(5^m)$$

When the bases on both sides of an equation are equal and the bases are prime numbers, the exponents of the respective bases must also be equal:  $a = k + 2$ ;  $b = l + 1$ ; and  $c = m$ . Now recall that  $a$ ,  $b$ , and  $c$  represent the hundreds, tens, and units digits of the three-digit integer  $x$ ; similarly,  $k$ ,  $l$ , and  $m$  represent the hundreds, tens, and units digits of the three-digit integer  $y$ .

Therefore, the hundreds digit of  $x$  is 2 greater than the hundreds digit of  $y$ ; the tens digit of  $x$  is 1 greater than the tens digit of  $y$ ; finally, the units digit of  $x$  is equal to the units digit of  $y$ . Using this information, we can set up our subtraction problem and find the value of  $(x - y)$ :

$$\begin{array}{r} abc \\ - klm \\ \hline 210 \end{array}$$

The correct answer is C.

8. (1) SUFFICIENT: Statement(1) tells us that  $x > 2^{34}$ , so we want to prove that  $2^{34} > 10^{10}$ . We'll prove this by manipulating the expression  $2^{34}$ .

$$2^{34} = (2^4)(2^{30})$$

$$2^{34} = 16(2^{10})^3$$

Now  $2^{10} = 1024$ , and 1024 is greater than  $10^3$ . Therefore:

$$2^{34} > 16(10^3)^3$$

$$2^{34} > 16(10^9)$$

$$2^{34} > 1.6(10^{10}).$$

Since  $2^{34} > 1.6(10^{10})$  and  $1.6(10^{10}) > 10^{10}$ , then  $2^{34} > 10^{10}$ .

(2) SUFFICIENT: Statement (2) tells us that that  $x = 2^{35}$ , so we need to determine if  $2^{35} > 10^{10}$ . Statement (1) showed that  $2^{34} > 10^{10}$ , therefore  $2^{35} > 10^{10}$ .

The correct answer is D.

9. A radical expression in a denominator is considered non-standard. To eliminate a radical in the denominator, we can multiply both the numerator and the denominator by the conjugate of that denominator.

$$= \sqrt{3\sqrt{80} + \frac{3}{9 + 4\sqrt{5}} \left( \frac{9 - 4\sqrt{5}}{9 - 4\sqrt{5}} \right)}$$

$$= \sqrt{3\sqrt{16 \cdot 5} + \frac{27 - 12\sqrt{5}}{81 - (16)(5)}}$$

$$= \sqrt{12\sqrt{5} + 27 - 12\sqrt{5}}$$

$$= \sqrt{27}$$

$$= 3\sqrt{3}$$

The correct answer is C

10. First rewrite the expression in the question using only prime bases (4 is not prime), as follows:  $2^a 2^{2b}$ .

(1) SUFFICIENT: We can substitute  $-2b$  for  $a$  into the expression in the question. What is the value of  $(2^{-2b})(2^{2b})$ ?

This can be simplified to  $2^{-2b+2b} = 2^0 = 1$ .

(2) INSUFFICIENT: We have no information about the value of  $a$ .

The correct answer is A.

11. An effective strategy for problems involving exponents is to break the bases of all the exponents into prime factors. This technique will allow us to combine like terms:

$$27^{4x+2} \times 162^{-2x} \times 36^x \times 9^{6-2x} = 1$$

$$(3^3)^{4x+2} \times (2 \times 3^4)^{-2x} \times (2^2 \times 3^2)^x \times (3^2)^{6-2x} = 1$$

$$3^{12x+6} \times 2^{-2x} \times 3^{-8x} \times 2^{2x} \times 3^{2x} \times 3^{12-4x} = 1$$

$$2^{-2x+2x} \times 3^{12x+6-8x+2x+12-4x} = 1$$

$$2^0 \times 3^{2x+18} = 1$$

$$3^{2x+18} = 1$$

$$3^{2x+18} = 3^0$$

$$2x+18 = 0$$

$$2x = -18$$

$$x = -9$$

The correct answer is A.

12.

Let's rewrite the right side of the equation in base 2 and base 3:  $(2^{2x+1})(3^{2y-1}) = (2^3)^x(3^3)^y$ .

This can be rewritten as:  $(2^{2x+1})(3^{2y-1}) = 2^{3x}3^{3y}$

Since both bases on either side of the equation are prime, we can set the exponents of each respective base equal to one another:

$$2x + 1 = 3x, \text{ so } x = 1$$

$$2y - 1 = 3y, \text{ so } y = -1$$

Therefore,  $x + y = 1 + (-1) = 0$ .

The correct answer is C

13.

Before dealing with this expression, it is helpful to remember several general exponent rules:

When multiplying expressions with the same base, ADD the exponents first:

$$(3^2)(3^3) = (3)(3)(3)(3)(3) = 3^5 = 3^{2+3}$$

When dividing expressions with the same base, SUBTRACT the exponents first:

$$(3^5)/(3^2) = (3)(3)(3)(3)(3) / (3)(3) = (3)(3)(3) = 3^3 = 3^{5-2}$$

When raising a power to a power, combine exponents by MULTIPLYING them:

$$(3^2)^4 = (3^2)(3^2)(3^2)(3^2) = (3 \times 3)(3 \times 3)(3 \times 3)(3 \times 3) = (3)(3)(3)(3)(3)(3)(3)(3) = 3^8 = 3^{2(4)}$$

In this question, we are asked to solve an expression with many exponents, but none of them have common bases, at least not as currently written. However, some of the bases have prime factors in common. Look at each part of the expression and break each into its factored form.

If we look at the terms in the numerator on the left side:

$$6^2 = (2 \times 3)^2 = 2^2 \times 3^2$$

$$44 = 2 \times 2 \times 11 = 2^2 \times 11^1$$

$5^x$  cannot be factored

$$20 = 2 \times 2 \times 5 = 2^2 \times 5^1$$

Note that several of the terms in the numerator have bases in common, so the numerator simplifies by ADDING the exponents of those terms:

$$(2^2 \times 3^2)(2^2 \times 11^1)(5^x)(2^2 \times 5^1) = (2^6)(3^2)(5^{(x+1)})(11^1)$$

If we look at the terms in the denominator on the left side:

$$8^2 = (2 \times 2 \times 2)^2 = (2^3)^2 = 2^6$$

$$9 = 3 \times 3 = 3^2$$

On the right side of the equation:

$$1375 = 5 \times 5 \times 5 \times 11 = 5^3 \times 11^1$$

Now that each exponent and large number is expressed in terms of its prime factors, we can put

the equation back together. Then we'll see what can cancel to simplify the entire equation:  
 $(2^6)(3^2)(5^{(x+1)})(11^1) \div (2^6)(3^2) = 5^3 \times 11^1$   
Canceling the  $2^6$  and  $3^2$  that appear in the numerator and denominator of the left side, and canceling the 11 that appears on each side of the equal sign:

$$5^{(x+1)} = 5^3$$
$$x + 1 = 3$$
$$x = 2$$

The correct answer is D.

14.

If we know  $y$ , we can solve for  $x$ . Thus, we can rephrase the question, "What is  $y$ ?"

(1) SUFFICIENT: If  $y^2 = 625$ , we know that  $y = 25$  or  $-25$ . However, since  $5^x$  will be positive no matter what  $x$  is, and  $5^x = y$ , then  $y$  must be positive. Thus,  $y$  must be 25. If  $y$  is 25, we know that  $x = 2$ .

(2) SUFFICIENT: If  $y^3 = 15,625$ ,  $y$  must equal 25. (Tip: In order to understand a number like 15,625 exponentially, try breaking it down into its roots.  $15,625 = 5 \times 5 \times 5 \times 5 \times 5 \times 5 = 25 \times 25 = 25^3$ .) If  $y$  is 25, we know that  $x = 2$ .

The correct answer is D.

15.

This question might be rephrased "How many golf balls do Wendy and Pedro have combined?" Otherwise, we must simply find the number of balls possessed by Jim.

(1) INSUFFICIENT: Observe that Jim could have 2 balls and Wendy 6, or Jim could have 3 balls while Wendy has 9.

(2) INSUFFICIENT: If Pedro has  $1/2$  of the golf balls, Pedro has 12 balls. However, this statement gives no information about the number of balls possessed by Jim or Wendy.

(1) AND (2) SUFFICIENT: Statement (2) tells us that Pedro has 12 balls. Therefore, Wendy and Jim collectively have the remaining 12 balls. Statement (1) tells us that Jim has  $1/3$  of the number of Wendy's golf balls. Let  $j$  = the number of Jim's golf balls and  $w$  = the number of Wendy's golf balls.

$$j = w/3$$

Multiplying both sides by 3 yields

$$3j = w$$

Given that  $j + w = 12$ , we can substitute that  $j + 3j = 12$ . If  $4j = 12$ ,  $j = 3$ .

The correct answer is C.

16.

The best way to answer this question is to use the exponential rules to simplify the question stem, then analyze each statement based on the simplified equation.

$$(3^{27})(35^{10})(z) = (5^8)(7^{10})(9^{14})(x^y) \text{ Break up the } 35^{10} \text{ and simplify the } 9^{14}$$

$$(3^{27})(5^{10})(7^{10})(z) = (5^8)(7^{10})(3^{28})(x^y) \text{ Divide both sides by common terms } 5^8, 7^{10}, 3^{27}$$

$$(5^2)(z) = 3x^y$$

(1) SUFFICIENT: Analyzing the simplified equation above, we can conclude that  $z$  must have a factor of 3 to balance the 3 on the right side of the equation. Statement (1) says that  $z$  is prime, so  $z$  cannot have another factor besides the 3. Therefore  $z = 3$ .

Since  $z = 3$ , the left side of the equation is 75, so  $x^y = 25$ . The only integers greater than 1 that satisfy this equation are  $x = 5$  and  $y = 2$ , so statement (1) is sufficient. Put differently, the expression  $x^y$  must provide the two fives that we have on the left side of the equation. The only way to get two fives if  $x$  and  $y$  are integers greater than 1 is if  $x = 5$  and  $y = 2$ .

(2) SUFFICIENT: Analyzing the simplified equation above, we can conclude that  $x$  must have a factor of 5 to balance out the  $5^2$  on the left side. Since statement (2) says that  $x$  is prime,  $x$  cannot have any other factors, so  $x = 5$ . Therefore statement (2) is sufficient.

The correct answer is D.

17. It is tempting to express both sides of the equation  $4^{4x} = 1600$  as powers of 4 and to try and solve for  $x$ . However, if we do that, we get a power of five on the right side as well:

$$4^{4x} = 16 \times 100$$

$$4^{4x} = 4^2 \times 4 \times 25$$

$$4^{4x} = 4^3 \times 5^2$$

It becomes clear that  $x$  is not an integer and that we can't solve the question this way.

Let's try manipulating the expression about which we are being asked.

$$(4^{x-1})^2 = 4^{2x-2}$$

If we further simplify we get the expression  $4^{2x}/4^2$

To solve this expression, all we need is to find the value of  $4^{2x}$

Now let's look back at our original equation. If  $4^{4x} = 1600$ , we can find the value of  $4^{2x}$  by taking the square root of both sides of the equation. Taking the square root of an exponential expression is tantamount to halving its exponent.

$$4^{4x} = 1600$$

$$\sqrt{4^{4x}} = \sqrt{1600}$$

$$4^{2x} = 40$$

Since the question asks for  $4^{2x}/4^2$ , the answer is  $40/4^2$ , which simplifies to  $40/16$  or  $5/2$ .

The correct answer is D

18.

$$(15^x + 15^{x+1}) = 15^y 4^y$$

$$[15^x + 15^x(15^1)] = 15^y 4^y$$

$$(15^x)(1 + 15) = 15^y 4^y$$

$$(15^x)(16) = 15^y 4^y$$

$$(3^x)(5^x)(2^4) = (3^y)(5^y)(2^{2y})$$

Since both sides of the equation are broken down to the product of prime bases, the respective exponents of like bases must be equal.

$2y = 4$  so  $y = 2$ .

$$x = y \text{ so } x = 2.$$

The correct answer is A

19.

In problems that involve exponential expressions on both sides of the equation, it is imperative to rewrite the bases so that either the same base or the same exponent appears on both sides of the equation. Here, we can get a common base by replacing the 9 with  $3^2$ .

$$\begin{aligned}3^m 3^m 3^m &= 9^n \\3^m 3^m 3^m &= (3^2)^n \\3^{3m} &= 3^{2n}\end{aligned}$$

Since the bases are the same, the exponents must be equal.

$$\begin{aligned}3m &= 2n \\m/n &= 2/3\end{aligned}$$

The correct answer is B

20.

(1) SUFFICIENT: We can rewrite this equation in a base of 3:  $3^{b+2} = 3^5$ , which means that  $b + 2 = 5$  and therefore  $b = 3$ .

We can plug this value into the equation  $a = 3^{b-1}$  to solve for  $a$ .

(2) SUFFICIENT: We can set the right side of this equation equal to the right side of the equation in the question (both sides equal  $a$ ).

$3^{b-1} = 3^{2b-4}$ , which means that  $b - 1 = 2b - 4$  and therefore  $b = 3$ . We can plug this value into the equation  $a = 3^{b-1}$  to solve for  $a$ .

The correct answer is D

21.

Recognize here the basic form  $(x-y)^2$ , which equals  $x^2 - 2xy + y^2$ .

$\sqrt{7 + \sqrt{29}}$  corresponds here to  $x$ , and  $\sqrt{7 - \sqrt{29}}$  corresponds to  $y$ .

So the expression can be simplified to:

$$\begin{aligned}(\sqrt{7 + \sqrt{29}})^2 - 2(\sqrt{7 + \sqrt{29}})(\sqrt{7 - \sqrt{29}}) + (\sqrt{7 - \sqrt{29}})^2 &\rightarrow \\7 + \sqrt{29} - 2\sqrt{(7 + \sqrt{29})(7 - \sqrt{29})} + 7 - \sqrt{29} &\rightarrow \\14 - 2\sqrt{(7 + \sqrt{29})(7 - \sqrt{29})}\end{aligned}$$

Under the radical, recognize the basic form  $(a + b)(a - b)$ , which equals  $a^2 - b^2$ .

The expression can be further simplified to:

$$14 - 2\sqrt{49 - 29} \rightarrow$$

$$14 - 2\sqrt{20} \rightarrow$$

$$14 - 4\sqrt{5}$$

The correct answer is C

22.

The key to this question is to recognize the common algebraic identity:

$$a^2 - b^2 = (a + b)(a - b)$$

In this question, the  $a$  term is  $x/3$  and the  $b$  term is  $2/y$ , which makes the identity from the question equal to:

$$x^2/9 - 4/y^2 = (x/3 - 2/y)(x/3 + 2/y) = 12$$

(1) SUFFICIENT:

Substituting the information from this statement into the equation from the question:

$$(x/3 - 2/y)(x/3 + 2/y) = 12$$

$$(x/3 - 2/y)(6) = 12$$

$$x/3 - 2/y = 2$$

We now have two equations with  $x$  and  $y$ :

$$x/3 + 2/y = 6 \text{ (from this statement)}$$

$$x/3 - 2/y = 2 \text{ (from the substitution above)}$$

Combine the two equations (by adding), then simplify:

$$(2)(x/3) = 8 \text{ (the } y \text{ terms cancelled)}$$

$$x/3 = 4$$

$$x = 12$$

(2) SUFFICIENT:

Substituting the information from this statement into the equation from the question:

$$(x/3 - 2/y)(x/3 + 2/y) = 12$$

$$(2)(x/3 + 2/y) = 12$$

$$x/3 + 2/y = 6$$

We now have two equations with  $x$  and  $y$ :

$$x/3 - 2/y = 2 \text{ (from this statement)}$$

$$x/3 + 2/y = 6 \text{ (from the substitution above)}$$

Combine the two equations (by adding), then simplify:

$$(2)(x/3) = 8 \text{ (the } y \text{ terms cancelled)}$$

$$x/3 = 4$$

$$x = 12$$

The correct answer is D

23.

We can determine the value of  $(a + b)^2$  in one of three ways: by figuring out the sum of  $a$  and  $b$ , by determining what  $a$  and  $b$  are separately, or by determining the value of  $a^2 + 2ab + b^2$  (which is the quadratic form of our product of factors).

(1) INSUFFICIENT: After multiplying both sides by  $b$  we can determine that  $ab = 15$ , but we

know nothing else.

(2) INSUFFICIENT: If we FOIL  $(a - b)^2$  we can learn that  $a^2 - 2ab + b^2 = 4$ . Alternatively, this statement also indicates that  $(a - b) = 2$  or  $-2$ . However, neither of these manipulations allow us to determine the sum of  $a$  and  $b$ , the respective values of  $a$  and  $b$  individually, or the value of  $a^2 + 2ab + b^2$ .

(1) AND (2) SUFFICIENT: Statement 1 tells us  $ab = 15$ . If we substitute this into the quadratic equation from the second statement, we can determine the value of  $a^2 + b^2$  in the following manner:

$$\begin{aligned}a^2 - 2(15) + b^2 &= 4 \\a^2 - 30 + b^2 &= 4 \\a^2 + b^2 &= 34\end{aligned}$$

If we know the value of  $a^2 + b^2$ , and the value of  $ab$ , we can determine the value of  $a^2 + 2ab + b^2$ .

$$\begin{aligned}a^2 + 2ab + b^2 &= \\a^2 + b^2 + 2ab &= \\34 + 2(15) &= 64\end{aligned}$$

The correct answer is C

24.

The equation  $x^2y^2 = 18 - 3xy$  is really a quadratic, with the  $xy$  as the variable.

$$\begin{aligned}x^2y^2 + 3xy - 18 &= 0 \\(xy + 6)(xy - 3) &= 0 \\xy &= 3 \text{ or } -6\end{aligned}$$

However, we are told that  $x$  and  $y$  are positive so  $xy$  must equal 3.

Therefore,  $x = 3/y$  and  $x^2 = 9/y^2$ .

Alternatively, this is a VIC (variable in choice) and can be solved by plugging numbers. If we plug a value for  $y$  and find the corresponding value of  $x$ , we can check the answers to see which one matches the value of  $x$ .

Looking at the values 3 and 18 in the equation, a  $y$  value of 3 makes sense.

$$\begin{aligned}x^2(3)^2 &= 18 - 3(x)(3) \\9x^2 &= 18 - 9x \\9x^2 - 9x + 18 &= 0 \\x^2 - x + 2 &= 0 \\(x + 2)(x - 1) &= 0 \\x &= 1, -2\end{aligned}$$

But since  $x$  cannot be negative,  $x = 1$

If we plug  $y = 3$  into each of the answer choices, (C) and (D) both give an  $x$  value of 1.

- (A)  $1/3$
- (B) 2
- (C) 1
- (D) 1
- (E) 4

We must now plug another value of  $y$  to decide between (C) and (D). Ultimately, only (D) represents the correct value each time.

The correct answer is D

25.

This equation can be manipulated into a quadratic equation by squaring both sides:

$$y = \sqrt{3y + 4}$$

$$y^2 = 3y + 4$$

$$y^2 - 3y - 4 = 0$$

This quadratic equation can be factored to

$$(y + 1)(y - 4) = 0$$

There are two possible solutions for  $y$ : -1 and 4. The product of the two possible solutions for  $y$  is -4.

The correct answer is A

26.

We know that the sum of the cubes of  $a$  and  $b$  is 8:  $a^3 + b^3 = 8$ . We also know that  $a^6 - b^6 = 14$ . Using our knowledge of the quadratic template for the difference of two squares,  $x^2 - y^2 = (x + y)(x - y)$ , we can rewrite  $a^6 - b^6 = 14$  as follows:

$$(a^3)^2 - (b^3)^2 = 14$$

$$(a^3 - b^3)(a^3 + b^3) = 14$$

Substituting for  $a^3 + b^3$  gives:

$$(a^3 - b^3)(8) = 14$$

$$(a^3 - b^3) = 14/8 = 7/4$$

The correct answer is D

27.

One way to answer this question is to substitute  $1/x$  for  $x$  and  $1/y$  for  $y$  in the expression, then simplify the resulting expression.

$$1/x + 1/y$$

$$\frac{1/x - 1/y}{1/x - 1/y}$$

Multiply the numerator and the denominator by  $xy$  to eliminate the fractions.

$$\frac{xy(1/x + 1/y)}{xy(1/x - 1/y)} = \frac{(y + x)}{(y - x)}$$

Since this is not one of the answer choices, it is necessary to simplify further. With the knowledge that  $y + x = x + y$  and  $y - x = -(x - y)$ , it can be stated that

$$\frac{(y + x)}{(y - x)} = - \frac{(x + y)}{(x - y)}$$

The correct answer is A

28.

When a problem involves variables raised to the fourth power, it is often useful to represent them as a square of another square, since this approach will allow us to apply manipulations of squares. Also note that since we are dealing with high exponents, the approach of plugging numbers would prove time-consuming and prone to error in this case.

Therefore, let's use algebra to solve this problem. Note that  $9x^4 - 4y^4 = (3x^2)^2 - (2y^2)^2$ . We can represent this expression using the formula for the difference of two squares:  $9x^4 - 4y^4 = (3x^2)^2 - (2y^2)^2 = (3x^2 + 2y^2)(3x^2 - 2y^2)$ .

Let's use this shortcut to simplify the equation:

$$9x^4 - 4y^4 = 3x^2 + 2y^2$$

$$(3x^2 + 2y^2)(3x^2 - 2y^2) = (3x^2 + 2y^2)$$

At this step, our first instinct may be to divide both sides of the equation by  $(3x^2 + 2y^2)$ . Remember that in order to divide both sides of the equation by an algebraic expression, we need to know that the value of this expression is not equal to zero, since dividing by zero results in an undefined outcome. By looking again at the question, we see that  $x$  and  $y$  are both non-zero integers, so  $(3x^2 + 2y^2)$  cannot be equal to zero. Therefore, we can indeed simplify the equation further by dividing out the  $(3x^2 + 2y^2)$  from each side:

$$(3x^2 - 2y^2) = 1$$

$$3x^2 = 2y^2 + 1$$

$$x^2 = (2y^2 + 1)/3$$

Note that we could also have found the correct answer by plugging in numbers at this stage (since we have eliminated the high exponents in the equation). For example, if we plug in  $y = 2$  to the equation  $(3x^2 - 2y^2) = 1$ , we see that  $x^2 = 3$ . Now we can plug  $y = 2$  into each of the answer choices to find that only C also gives us  $x^2 = 3$ .

Finally, if we are careful, we might also see that answer choices A and B cannot be correct because they are negative, and no non-zero integer squared can equal a negative number.

The correct answer is C

29. To find the ratio of  $r$  to  $s$ , we need to be able to solve EITHER for  $r/s$  OR for  $r$  and  $s$  independently.

(1) INSUFFICIENT: The equation provided in statement 1 cannot be rewritten in the form  $r/s =$  some value.

(2) INSUFFICIENT: The equation provided in statement 2 can be simplified as follows:

$$r^2 - s^2 = 7$$

$$(r + s)(r - s) = 7.$$

However, this cannot be rewritten in the form  $r/s =$  some value.

(1) AND (2) SUFFICIENT: We can substitute the information from statement (1) in the equation from statement 2 as follows:

$$(r + s)(r - s) = 7.$$

$$(7)(r - s) = 7.$$

$$r - s = 1.$$

Adding this equation to the equation from the first statement allows us to solve for  $r$ .

$$\begin{array}{r} (r - s = 1) \\ + (r + s = 7) \\ \hline 2r = 8 \end{array}$$

Thus,  $r = 4$ . If  $r$  is 4, then  $s$  must be 3. The ratio of  $r$  to  $s$  is 4 to 3.

The correct answer is C

30.

$z$  is the difference between the number of men and the number of women in the choir; hence  $z = x - y$ . In order to answer the question "what is  $z$ ?", we need to be able to determine either the value of the quantity  $x - y$ , or the values of both  $x$  and  $y$  from which quantity  $x - y$  can be computed.

(1) SUFFICIENT: After adding 9 to both sides of the equation, we get  $x^2 - 2xy + y^2 = 9$ . Since we are interested in the variables  $x$  and  $y$ , it would be helpful to rearrange the expression  $x^2 - 2xy + y^2$  into an expression that contains terms for  $x$  and  $y$  individually. This suggests that factoring the expression into a product of two sums is in order here. Since the coefficients of both the  $x^2$  and the  $y^2$  terms are 1 and the coefficient of the  $xy$  term is negative, the most logical first guess for factors is  $(x - y)(x - y)$  or  $(x - y)^2$ . (We can quickly confirm that these are the correct factors by multiplying out  $(x - y)(x - y)$  and verifying that this is equal to  $x^2 - 2xy + y^2$ .) Hence, we now have  $(x - y)^2 = 9$  or  $x - y = 3$  or  $-3$ . Since the stimulus states that  $z$  or  $x - y$  is a physical quantity ("there are  $z$  more men than women..."), the only answer that makes logical sense is  $x - y = 3$ .

(2) INSUFFICIENT: After adding 225 to both sides of the equation, we get  $x^2 + 2xy + y^2 = 225$ . Since we are interested in the variables  $x$  and  $y$ , it would be helpful to rearrange the expression  $x^2 + 2xy + y^2$  into an expression that contains terms for  $x$  and  $y$  individually. This suggests that factoring the expression into a product of two sums is in order here. Since the coefficients of both the  $x^2$  and the  $y^2$  terms are 1 and the coefficient of the  $xy$  term is positive, the most logical first guess for factors is  $(x + y)(x + y)$  or  $(x + y)^2$ . (We can quickly confirm that these are the correct factors by multiplying out  $(x + y)(x + y)$  and verifying that this is equal to  $x^2 + 2xy + y^2$ .) Hence, we now have  $(x + y)^2 = 225$  or  $x + y = 15$  or  $-15$ . Even if we could pinpoint the value of  $x + y$  to one of those two values, this knowledge would not give us any insight as to the value of the quantity  $x - y$ , or the values of  $x$  and  $y$  individually.

The correct answer is A

31.

In this problem, we are given the information to set up the following three equations with three unknowns:

$$x = z/4$$

$$x + y + z = 26$$

$$y = 2z$$

Using the method of substitution, we can now solve for each of the three unknowns.

Since the first equation,  $x = z/4$ , is an equation for  $x$  in terms of  $z$ , and the third equation,  $y = 2z$ , is an equation for  $y$  in terms of  $z$ , we can replace  $x$  and  $y$  in the second equation by their

equivalent expressions as follows:

$$x + y + z = (z/4) + (2z) + z = 26$$

We are left with an equation with just one unknown  $z$ . We can now solve for  $z$ :

$$(z/4) + (2z) + z = 26$$

$$z/4 + 8z/4 + 4z/4 = 13z/4 = 26$$

$$z/4 = 2$$

$$z = 8$$

Now that we know  $z$ , we can easily solve for  $y$ , then compute  $y + z$  (note: we can also solve for  $x$ , but since we are not interested in the value of  $x$  there is no need to do so):

$$y = 2z = 2(8) = 16$$

$$y + z = 16 + 8 = 24$$

Since the largest factor of any number is the number itself, the largest factor of the sum of  $y$  and  $z$  is 24.

The correct answer is E

32.

Solve the original equation for  $b$ :

$$2 + 5a - b/2 = 3c$$

$$2 + 5a - 3c = b/2$$

$$4 + 10a - 6c = b$$

Knowing the value of  $10a - 6c$  will allow us to calculate the value of  $b$ . So, the rephrased question becomes: "What is  $10a - 6c$ ?"

(1) INSUFFICIENT: Knowing the sum of  $a$  and  $c$  is not enough to determine the value of  $10a - 6c$ . For example, if  $a = 10$  and  $b = 3$ , then  $10a - 6c = 10(10) - 6(3) = 82$ . However, if  $a = 6$  and  $b = 7$ , then  $10a - 6c = 10(6) - 6(7) = 18$ .

(2) SUFFICIENT: Manipulating the equation gives us the following:

$$-12c = -20a + 4$$

$$20a - 12c = 4$$

$$10a - 6c = 2$$

The correct answer is B

33.

(1) INSUFFICIENT: We can start manipulating this equation by multiplying both sides by  $xy$ . However, we see that the value of  $xy$  depends on the values of  $x$  and  $y$ .

$$xy \left( \frac{2}{x} + \frac{2}{y} \right) = 3xy$$

$$2y + 2x = 3xy$$

$$\frac{2y + 2x}{3} = xy$$

The value of  $xy$  changes according to the values of  $x$  and  $y$ .

(2) SUFFICIENT: If we manipulate this equation and solve for  $xy$ , we come up with a distinct value for  $xy$ .

$$x^3 - \frac{8}{y^3} = 0$$

$$x^3 = \frac{8}{y^3}$$

$$x^3 y^3 = 8$$

$$xy = 2$$

The correct answer is B

34.

To simplify a radical in the denominator of a fraction, you must multiply the denominator by something that will cause the radical to disappear. You must also multiply the numerator by this same value so as not to change the value of the fraction. (In effect, by multiplying the numerator and the denominator by the same value, you are multiplying the entire fraction by 1.)

What will cause the radical in denominator to disappear? Multiply the denominator  $2 + \sqrt{3}$  by its complement,  $2 - \sqrt{3}$ , as follows:

$$\frac{3}{2 + \sqrt{3}} \left( \frac{2 - \sqrt{3}}{2 - \sqrt{3}} \right) = \frac{6 - 3\sqrt{3}}{4 - 3} = 6 - 3\sqrt{3}$$

The correct answer is B

35.

$$(1/5)^m \cdot (1/4)^{18} = (1/5^m) \cdot (1/2^{36}) = 1/(5^m \cdot 2^{36}) = 1/2(5^m \cdot 2^{35})$$

$$1/2(5^m \cdot 2^{35}) = 1/2(10)^{35}, \text{ means that } 5^m \cdot 2^{35} = 10^{35}.$$

Obviously,  $m$  is 35

36.

$$1 \cdot 4^{11} \text{ can be expressed at the format } 2 \cdot 10^n \cdot 5^{21} \cdot 4^{115} \cdot 21 \cdot 2^{22} = 2 \cdot 10^{21}.$$

So,  $n=21$

37.

We can rewrite  $3^{11}$  as  $3^3 \times 3^3 \times 3^3 \times 3^2$ . Since  $5^2$  (or 25) is quite close to  $3^3$  (or 27), we can replace each  $3^3$  with  $5^2$  since the question asks us to approximate.

$$\text{The expression becomes } 5^{28} + (5^2 \times 5^2 \times 5^2 \times 3^2) = 5^q \text{ or } 5^{28} + 5^6(3^2) = 5^q$$

$$\text{We can factor out a } 5^6 \text{ as follows: } 5^6(5^{22} + 3^2) = 5^q$$

Since  $3^2$  (or 9) is insignificant compared to  $5^{22}$  (a huge number), we can approximate the expression as:  $5^6(5^{22})$ .  $q$  is approximately equal to 28.

Another way to look at this problem is to realize that while  $3^{11}$  is a big number, it pales in comparison to  $5^{28}$ . The effect of adding  $3^{11}$  to  $5^{28}$  will be much less than multiplying  $5^{28}$  by another 5 (i.e.  $5^{29}$ ). To prove this, let's look at two smaller numbers, such as  $5^4$  (625) and  $3^3$  (27). When you add 27 to 625, the sum is much closer to  $5^4$  (625) than to  $5^5$  (3125). The correct answer is C.

38.

The expression in the question can be simplified:

$$\frac{2^x + 2^x}{2^y} = \frac{2(2^x)}{2^y} = \frac{2^{x+1}}{2^y} = 2^{x-y+1}$$

The question can be rephrased as "what is  $x - y$ ?" since that would suffice to help us solve the expression.

(1) SUFFICIENT: The statement provides us with a value for  $x - y$ .

(2) INSUFFICIENT: The statement cannot be manipulated to come up with a value for  $x - y$ , nor can it alone provide a value for  $x$  and  $y$ .

The correct answer is A.

39.

We can rephrase the question as "What is  $y$ ?" or since we know that  $\sqrt{x} = y$ , "What is  $x$ ?"

(1) SUFFICIENT: From the question we know that  $\sqrt{x} = y$ , so  $x = y^2$ . According to the statement, we also know that  $x = yx$ . If we set the two equations equal to one another,  $y^2 = yx$ .  $x$  then must be equal to  $y$ . (There is another solution to this equation: Both  $x$  and  $y$  are equal to 1. However, the question stem states that  $x$  is not equal to  $y$  so we can eliminate this possibility.)

(2) SUFFICIENT: If we take the cube root of both sides of the equation  $x^3 = 8$ , we find that  $x = 2$ .

The correct answer is D.

40.

(1) INSUFFICIENT: This gives us a range of possible values for  $y$ . The low end of the range ( $1/5$ ) is smaller than  $7/11$ , while the high end of the range ( $11/12$ ) is greater than  $7/11$ . Thus, we cannot determine whether  $y$  is greater than  $7/11$ .

(2) SUFFICIENT: This gives us a range of possible values for  $y$ . The low end of the range ( $2/9$ ) is smaller than  $7/11$ , and the high end of the range ( $8/13$ ) is *also* smaller than  $7/11$ . Thus,  $y$  cannot be greater than  $7/11$ .

The correct answer is B.

41.

The key to this question is to recognize the two common algebraic identities:

$$(x + y)^2 = x^2 + 2xy + y^2$$

$$(x + y)(x - y) = x^2 - y^2$$

In this question the  $x$  term is  $\sqrt{x}$  and the  $y$  term is  $\sqrt{y}$ , which makes the two identities equal to:

$$(\sqrt{x} + \sqrt{y})^2 = x + 2\sqrt{xy} + y$$

$$(\sqrt{x} - \sqrt{y})(\sqrt{x} + \sqrt{y}) = x - y$$

If we simplify the equation using these identities, we get:

$$\frac{\sqrt{x} + \sqrt{y}}{x - y} = \frac{2\sqrt{x} + 2\sqrt{y}}{x + 2\sqrt{xy} + y} \rightarrow$$

$$\frac{\sqrt{x} + \sqrt{y}}{(\sqrt{x} - \sqrt{y})(\sqrt{x} + \sqrt{y})} = \frac{2(\sqrt{x} + \sqrt{y})}{(\sqrt{x} + \sqrt{y})(\sqrt{x} + \sqrt{y})} \rightarrow$$

$$\frac{1}{\sqrt{x} - \sqrt{y}} = \frac{2}{\sqrt{x} + \sqrt{y}} \rightarrow$$

$$\sqrt{x} + \sqrt{y} = 2\sqrt{x} - 2\sqrt{y} \rightarrow$$

$$3\sqrt{y} = \sqrt{x} \rightarrow$$

$$(3\sqrt{y})^2 = (\sqrt{x})^2 \rightarrow$$

$$9y = x \rightarrow$$

$$\frac{x}{y} = \frac{9}{1}$$

The correct answer is E

42.

(1) INSUFFICIENT: You cannot simply divide both sides of the equation by  $p$  to obtain  $pq = 1$ . The reason is that you don't know whether or not  $p$  is zero -- and remember, you are not allowed to divide by zero! Instead, you must factor this equation.

First, subtract  $p$  from both sides to get:  $pqp - p = 0$ .

Then, factor out a common  $p$  to get:  $p(pq - 1) = 0$ . This means that either  $pq = 1$  or  $p = 0$ .

(2) INSUFFICIENT: The same process applies here as with statement (1). Remember, you should never divide both sides of an equation by a variable that could be zero.

First, subtract  $q$  from both sides to get:  $qpq - q = 0$ .

Then, factor out a common  $q$  to get:  $q(pq - 1) = 0$ . This means that either  $pq = 1$  or  $q = 0$ .

(1) AND (2) INSUFFICIENT: Together we still don't have enough information to solve. Either  $pq = 1$  or both  $p$  and  $q$  are 0.

The correct answer is E

43.

Notice that the identity in the numerator of the original fraction is written in the form  $x^2 - y^2$ , with  $x = 4x^2$ , and  $y = 9y^2$ ; to factor, rewrite it as  $(x + y)(x - y)$ , or  $(4x^2 + 9y^2)(4x^2 - 9y^2)$ . We can also factor the right side of the first equation:

$$\frac{16x^4 - 81y^4}{2x + 3y} = 12x^2 + 27y^2$$

$$\frac{(4x^2 + 9y^2)(4x^2 - 9y^2)}{2x + 3y} = 3(4x^2 + 9y^2)$$

$$\frac{\cancel{(4x^2 + 9y^2)} \cancel{(2x + 3y)} (2x - 3y)}{\cancel{2x + 3y}} = 3 \cancel{(4x^2 + 9y^2)}$$

$$2x - 3y = 3$$

We can combine this equation with the other equation in the question:

$$\begin{array}{r} 2x - 3y = 3 \\ 4x + 3y = 9 \\ \hline 6x = 12 \\ x = 2 \end{array}$$

The correct answer is C.

44.

$$\begin{aligned} \text{Since } f(x) &= ax^4 - 4x^2 + ax - 3, \\ f(b) &= ab^4 - 4b^2 + ab - 3 \\ &= ab^4 - 4b^2 + ab - 3 \end{aligned}$$

AND

$$\begin{aligned} f(-b) &= ax^4 - 4x^2 + ax - 3 \\ &= a(-b)^4 - 4(-b)^2 + a(-b) - 3 \\ &= ab^4 - 4b^2 - ab - 3 \end{aligned}$$

Therefore:

$$f(b) - f(-b) = ab^4 - 4b^2 + ab - 3 - (ab^4 - 4b^2 - ab - 3) = 2ab$$

Alternatively, we could have recognized that the only term of the function that will be different for  $f(b)$  than for  $f(-b)$  is the "ax." The other three terms are all unaffected by the sign of the variable. More succinctly,  $f(b) - f(-b)$  must equal  $ab - (-ab) = 2ab$ .

The correct answer is B

45.

We are told that  $p \& q = p^2 + q^2 - 2pq$ . In order for  $p \& q = p^2$ , the value of  $q^2 - 2pq$  must equal 0. We can solve this as follows:

$$q^2 - 2pq = 0$$

$$q(q - 2p) = 0$$

The solution that would work for all value of  $p$  is if  $q = 0$ .

In plugging  $q = 0$  back into the original function, we get:

$$p \& q = p^2 + 0^2 - 2p(0) = p^2.$$

The correct answer is C

46.

The expression in the question can be rewritten as  $\frac{1}{t^2 u^3}$ .

(1) SUFFICIENT: This statement can be rewritten as follows:

$$\frac{1}{t^3 u^2} = 36$$

Therefore,  $t^3 u^2 = 36$ . The only positive integers that satisfy this expression are  $t = 1$  and  $u = 6$ . Since we know the values of  $t$  and  $u$ , we can solve the expression in the question.

(2) INSUFFICIENT: This statement can be rewritten as follows:

$$\frac{t(u^3)}{u} = 6$$

There are many possible values for  $t$  and  $u$ . For example,  $t$  could be 2 and  $u$  could be 12. Alternatively,  $t$  could be 1 and  $u$  could be 6. Since, there are many possibilities for  $t$  and  $u$ , we are not able to solve the expression in the question.

The correct answer is A.

---

47.

The key to this problem is recognizing that the expression  $a - b$  can be factored as the difference of two squares ( $x^2 - y^2$ ), where  $x = \sqrt{a}$  and  $y = \sqrt{b}$ .

The left side of the equation  $a - b = \sqrt{a} - \sqrt{b}$  can be factored as follows:

$$(\sqrt{a} + \sqrt{b})(\sqrt{a} - \sqrt{b}) = \sqrt{a} - \sqrt{b}$$

$$\sqrt{a} + \sqrt{b} = 1$$

$$a = (1 - \sqrt{b})^2$$

$$a = 1 - 2\sqrt{b} + b$$

The correct answer is C

48.

There is no useful rephrase of the question, so the best approach here is to analyze the statement to see what they tell us about the values of  $a$ ,  $b$ ,  $c$ , and  $d$ .

Statement 1 tells us that  $b!d! = 4(a!d!)$ . If we divide both sides by  $d!$ , we are left with  $b! = 4a!$ . Remember that to find the factorial value of an integer, you multiply that integer by every positive integer smaller than it. Since  $b!$  is 4 times greater than  $a!$ , it must be true that  $b! = 4 \times a \times (a - 1) \times (a - 2) \dots$ . Since  $b!$  is a factorial product and cannot have more than one 4 as a factor, it must be true that  $b! = 4 \times 3 \times 2 \times 1$ . Therefore,  $a = 3$  and  $b = 4$ . But this tells us nothing about  $c$  or  $d$ . Insufficient.

Statement 2 tells us that  $60(b!c!) = (b!d!)$ . If we divide both sides by  $b!$ , we are left with  $60c! = d!$ . Since  $d!$  is 60 times greater than  $c!$ ,  $d!$  could equal  $60!$  (i.e.,  $60 \times 59 \times 58 \dots$ ), and therefore  $d = 60$  and  $c = 59$ . Or  $d!$  could equal  $(c!)(3)(4)(5)$ , in which case  $c!$  must be  $2!$  and  $c = 2$  and  $d = 5$ . Insufficient.

If we pool the information from both statements, however, we see that  $60(b!c!) = 4(a!d!)$ , which yields  $15(b!c!) = (a!d!)$ . If we try this equation with  $a = 3$ ,  $b = 4$ ,  $c = 59$ , and  $d = 60$ , we get  $15(4!59!) = (3!60!)$  or  $60(3!59!) = (3!60!)$ , which is the same as  $3!60! = 3!60!$ . So these four values are possible.

If we try the equation with  $a = 3$ ,  $b = 4$ ,  $c = 2$ , and  $d = 5$ , we get  $15(4!2!) = (3!5!)$  or  $(3)(5)(4!2!) = (3!5!)$ , which is the same as  $5!3! = 3!5!$ . So these four values are possible as well.

Since the value of  $c$  can be either 2 or 59 and the value of  $d$  can be either 5 or 60, we cannot answer the question definitively.

The correct answer is E.

49.

The simplest approach to this problem is to pick numbers. Let's say that  $x = 1$ . We can plug in 1 for  $x$  in  $f_{(5x)}$ :

$$f_{(5(1))} \rightarrow$$

$$f_{(5)} \rightarrow$$

$$f_{(5)} = \frac{125}{(5)^3} \rightarrow$$

$$\frac{125}{125} = 1$$

And we can plug in 1 for  $x$  in  $f_{(x/5)}$ :

$$f_{(1/5)} = \frac{125}{\left(\frac{1}{5}\right)^3} \rightarrow$$

$$\frac{125}{\left(\frac{1}{125}\right)} \rightarrow$$

$$(125)(125) \rightarrow$$

$$125^2$$

Therefore,  $(f_{(5x)})(f_{(x/5)})$  will be equal to  $(1)(125^2) = 125^2$ . If we evaluate each choice by plugging in 1 for  $x$ , the only one to give  $125^2$  as an answer is A:

$$(f_{(1)})^2 \rightarrow$$

$$\left(\frac{125}{(1)^3}\right)^2 \rightarrow$$

$$125^2$$

Alternatively, we can solve algebraically.

First, let's calculate the value of  $f_{(5x)} : \frac{125}{(5x)^3}$ . We can simplify this in terms of  $f_{(x)}$ :

$$\begin{aligned} &\left(\frac{1}{125}\right)\left(\frac{125}{x^3}\right) \rightarrow \\ &\left(\frac{1}{125}\right)(f_{(x)}) \rightarrow \\ &\frac{f_{(x)}}{125} \end{aligned}$$

Now let's calculate the value of  $f_{(x/5)} : \left(\frac{125}{x^3}\right)$ . We can simplify this in terms of  $f_{(x)}$ :

$$\begin{aligned} &\frac{125}{\left(\frac{x^3}{125}\right)} \rightarrow \\ &(125)\left(\frac{125}{x^3}\right) \rightarrow \\ &(125)(f_{(x)}) \end{aligned}$$

We can now see that  $(f_{(5x)})(f_{(x/5)})$  is equal to the following:

$$\begin{aligned} &\left(\frac{f_{(x)}}{125}\right)(125)(f_{(x)}) \rightarrow \\ &(f_{(x)})(f_{(x)}) \rightarrow \\ &(f_{(x)})^2 \end{aligned}$$

The correct answer is A.

50.

First, simplify the numerator by letting  $x = ab$ . Then the numerator can be simplified as follows:

$$\begin{aligned} &3x^3 + 9x^2 - 54x \\ &3x(x^2 + 3x - 18x) \\ &3x(x+6)(x-3) \end{aligned}$$

Substituting  $ab$  back in for  $x$ , the original equation now looks like this:

$$\frac{3ab(ab+6)(ab-3)}{(a-1)(a+2)} = 0$$

In order for the fraction to have a value of 0, the numerator must have a value of 0.

Thus,  $ab$  can be equal to 0, -6, or 3. However, since we are told that  $a$  and  $b$  are both nonzero integers,  $ab$  cannot be 0 and it must be equal to -6 or 3. Therefore,  $a$  and  $b$  must be integer factors of -6 or 3. Thus it would appear that:

$b$  can be equal to 2, if  $a = -3$   
 $b$  can be equal to 3, if  $a = -2$   
 $b$  can be equal to 3, if  $a = 1$

However,  $a$  cannot be equal to -2 or 1, since this would make the denominator equal to 0 and leave the fraction undefined. This leaves one option:  $a = -3$  and  $b = 2$ . The correct answer is A (I only): the variable  $b$  can be equal to 2, not 3 or 4.

51.

This problem can be solved either algebraically or by picking numbers.

If the greater of the two integers is  $x$ , then the two integers can be expressed as  $x - 1$  and  $x$ . The sum of the reciprocals would therefore be

$$\frac{1}{x-1} + \frac{1}{x}$$
$$\frac{x}{x(x-1)} + \frac{x-1}{x(x-1)}$$
$$\frac{2x-1}{x^2-x}$$

52.

First, look at statement (1) by itself.

$$y = x(x-3)(x+3)$$

Distributing the right side of the equation:

$$y = x(x^2 - 9)$$
$$y = x^3 - 9x$$

Subtract everything on the right from both sides to get:

$$y - x^3 + 9x = 0, \text{ which almost looks like the expression in the question.}$$

To make the left side of the equation match the question, subtract  $8x$  from both sides:

$$y - x^3 + x = -8x$$

We would be able to answer the question if only we knew the value of  $x$ , but that information is not given. Statement 1 is not sufficient.

Second, look at statement (2) by itself.

$$y = -5x$$

Since the question asks about a complicated expression of  $x$ 's and  $y$ 's, the simplest way to see if statement (2) is sufficient is to try to make one side of the equation in statement (2) match the question, then try to simplify the other side of the equation to a single value. Since the question asks about the value of  $y + x^3 + x$ , and statement (2) has  $y$  on the left side of the equation, add the "missing"  $x^3 + x$  to both sides of the equation in statement (2).

$$y + (x^3 + x) = -5x + (x^3 + x)$$

$$y + x^3 + x = x^3 - 4x$$

$$y + x^3 + x = x(x^2 - 4)$$

We would be able to answer the question if only we knew the value of  $x$ , but that information is not given. Statement 2 is not sufficient.

Finally, look at both statements together.

Since both give expressions for  $y$ , set the right sides of each statement equal to each other:

$$-5x = x(x - 3)(x + 3)$$

$$-5x = x(x^2 - 9)$$

$$-5x = x^3 - 9x$$

$$0 = x^3 - 4x$$

$$0 = x(x^2 - 4)$$

$$0 = x(x - 2)(x + 2)$$

So, there are three solutions for  $x$ :  $\{0, 2, \text{ or } -2\}$ . At first, the statements together might seem insufficient, since this yields three values. However, the question is not asking the value of  $x$ , rather the value of  $y + x^3 + x$ . It is a good idea to find the value of  $y$  for each  $x$  value, then solve for the expression in the question.

$$\text{When } x = 0, y = 0 \text{ and } y + x^3 + x = 0 + 0 + 0 = 0$$

$$\text{When } x = 2, y = -10 \text{ and } y + x^3 + x = -10 + 8 + 2 = 0$$

$$\text{When } x = -2, y = 10 \text{ and } y + x^3 + x = 10 - 8 - 2 = 0$$

The answer must be zero, so the two statements together are sufficient. The correct answer is C.

53.

The key to solving this problem is to recognize that the two given equations are related to each other. Each represents one of the elements in the common quadratic form:

$$a^2 - b^2 = (a + b)(a - b)$$

$$3x - 2y - z = 32 + z$$

$$\text{Rewrite the given equation as follows: } 3x - (2y - 2z) = 32$$

Then, notice it's relationship to the second given equation:

$$\sqrt{3x} - \sqrt{2y + 2z} = 4$$

The second equation is in the form  $a - b = 4$ , while the first equation is in the form  $a^2 - b^2 = 32$  (where  $a = \sqrt{3x}$  and  $b = \sqrt{2y + 2z}$ ).

Since we know that and that  $a^2 - b^2 = 32$  and that  $a - b = 4$  we can solve for  $a + b$ , which must equal 8.

This gives us a third equation:  $\sqrt{3x} + \sqrt{2y + 2z} = 8$ .

Adding the second and third equations allows us to solve for  $x$  as follows:

$$\begin{array}{r} \sqrt{3x} - \sqrt{2y + 2z} = 4 \\ \sqrt{3x} + \sqrt{2y + 2z} = 8 \\ \hline 2\sqrt{3x} \qquad = 12 \\ \sqrt{3x} \qquad = 6 \\ 3x \qquad = 36 \\ x \qquad = 12 \end{array}$$

Plugging this value for  $x$  into the first equation allows us to solve for  $y + z$  as follows:

$$\begin{array}{r} 3x - 2y - 2z = 32 \\ 3(12) - 2y - 2z = 32 \\ -2y - 2z = -4 \\ y + z = 2 \end{array}$$

The question asks for the value of  $x + y + z$ .

If  $x = 12$  and  $y + z = 2$ , then  $x + y + z = 12 + 2 = 14$ .

The correct answer is E.

54.

If we square both sides of the equation, we get  $z^2 = 6zs - 9s^2$ . We can now put the quadratic in standard form  $z^2 - 6zs + 9s^2 = 0$  and factor  $(z - 3s)^2 = 0$ . Since  $z - 3s = 0$ ,  $z = 3s$ . This question can also be solved as a VIC by plugging a value for the variable  $s$ . If we say  $s = 2$ , and plug this value into the equation after it was squared, we get:

$$z^2 = 12z - 36$$

This can be written in standard form and factored:  $(z - 6)^2 = 0$ , which means that  $z = 6$ . Now we can see which answer choice(s) yield 6 as the value for  $z$  when we plug in  $s = 2$ . Only answer choice B works,  $3(2) = 6$ .

The correct answer is B.

55.

$$3^k + 3^k = (3^9)^{3^9} - 3^k$$

$$3^k + 3^k + 3^k = (3^{3^2})^{3^9}$$

$$3 \cdot 3^k = (3^{3^2})^{3^9}$$

$$3^{k+1} = 3^{3^2 \cdot 3^9}$$

$$3^{k+1} = 3^{3^{11}}$$

$$k + 1 = 3^{11}$$

$$k = 3^{11} - 1$$

56.

The left side of the equation  $a^{\frac{2}{3}} - b^{\frac{2}{3}} = 12$  fits the form  $a^{2x} - b^{2x}$ , which can be factored as  $(a^x + b^x)(a^x - b^x)$ .

Thus, we can rewrite the equation as  $(a^{\frac{1}{3}} + b^{\frac{1}{3}})(a^{\frac{1}{3}} - b^{\frac{1}{3}}) = 12$  OR  
 $(\sqrt[3]{a} + \sqrt[3]{b})(\sqrt[3]{a} - \sqrt[3]{b}) = 12$

Since  $(\sqrt[3]{a} + \sqrt[3]{b})(\sqrt[3]{a} - \sqrt[3]{b}) = 12$ , one way to solve for  $\sqrt[3]{a} + \sqrt[3]{b}$  is to find the value of  $\sqrt[3]{a} - \sqrt[3]{b}$ .

Another way to solve for  $\sqrt[3]{a} + \sqrt[3]{b}$  is to find the value of  $a$  and  $b$ .

(1) SUFFICIENT: We can subtract root 3 from both sides of the equation to obtain  $\sqrt[3]{a} - \sqrt[3]{b} = 2$ .

(2) INSUFFICIENT: We can plug  $a = 64$  into the original equation to solve for  $b$ .

$$(64)^{2/3} - b^{2/3} = 12$$

$$16 - b^{2/3} = 12$$

$$b^{2/3} = 4$$

$$b = 4^{3/2} = +/- 8$$

With a single value for  $a$  but two values for  $b$ , there are two solutions to the question.

The correct answer is A, Statement (1) ALONE is sufficient to answer the question, but statement (2) alone is not.

57.

To find the value of  $a-b$ , we must either find the values of  $a$  and  $b$  and subtract them or somehow manipulate an equation so that we can solve directly for the combined expression  $a-b$ .

Statement (1) can be rewritten as:

$$x^a = 3x^b$$

$$\frac{x^a}{x^b} = 3$$

$$x^{a-b} = 3^1$$

Since  $a$ ,  $b$ ,  $x$  and  $y$  are all positive integers,  $a-b$  must be an integer (although not necessarily a positive one). It may be easier to write this statement out in words: an integer ( $x$ ) raised to some integer power ( $a-b$ ) must equal three.

Since 3 is a prime number, it must follow that the base  $x$  is also 3. If  $x$  were something other than 3, there would be no way of raising it to an integer power and coming up with 3. Even the base 9, which is composed of only 3's, would need to be raised to a fractional exponent (i.e. square root = power of 1/2) to come up with 3.

If  $x$  must be 3, we can set up the following equation:  $3^{a-b} = 3^1$ . It follows that  $a-b = 1$  and statement (1) is SUFFICIENT. The answer must be A or D.

Statement (2) can be dealt with in a similar manner:

$$y^a = 4y^b$$

$$\frac{y^a}{y^b} = 4$$

$$y^{a-b} = 4^1 \quad \text{OR} \quad y^{a-b} = 2^2$$

Notice, however, that the expression  $y^{a-b}$  now equals 4, which is not a prime number. Because 4 can be expressed as  $4^1$  or  $2^2$ , the base  $y$  and the exponent  $a-b$  do not have fixed values. Statement (2) is INSUFFICIENT and the correct answer is A.

## 58.

When a binomial is expanded, the number of terms is always one more than the exponent of the binomial. For example,

$(a+b)^2 = a^2 + 2ab + b^2$ . There are three terms and three is one more than two, the exponent.

In this case, we have six terms, which means the value of  $x$  must be 5. We can now rewrite the expression in the question by substituting 5 for  $x$  as follows:

$$(a+b)^5 = a^5 + y(a^4b) + z(a^3b^2) + z(a^2b^3) + y(ab^4) + b^5$$

The question asks for the value of  $yz$ . To answer this we need to figure out the values of the coefficients  $y$  and  $z$ .

Let's consider the coefficient in an easier expression such as

$$(a + b)^2 = a^2 + 2ab + b^2$$

Notice that the coefficient 2 represents the number of ways that one  $a$  and one  $b$  can be multiplied together: either  $ab$  or  $ba$ .

This is akin to counting the number of permutations of 2 unique elements:  $2! = 2$ .

Similarly, in  $(a + b)^3 = a^3 + 3a^2b + 3b^2a + b^3$ , the coefficient 3 represents the number of ways you can multiply together two of the same term and one of the other:  $aab, aba, baa$  or  $bba, bab, abb$ .

This is akin to counting the number of permutations of 2 identical elements and 1 unique

one:  $\frac{3!}{2!} = \frac{3 \times 2 \times 1}{2 \times 1} = 3$

In the case at hand,  $(a + b)^5 = a^5 + y(a^4b) + z(a^3b^2) + z(a^2b^3) + y(ab^4) + b^5$ , we can figure out the value of the coefficient  $y$ , by counting the number of permutations of 4  $a$ 's and 1  $b$  (or 4  $b$ 's and 1  $a$ ):

$$\frac{5!}{4!} = \frac{5 \times 4 \times 3 \times 2 \times 1}{4 \times 3 \times 2 \times 1} = 5, \text{ so } y = 5.$$

To figure out the value of the coefficient of  $z$ , we need to count the number of permutations of 3  $a$ 's and 2  $b$ 's (or 2  $b$ 's and 3  $a$ 's):

$$\frac{5!}{3!2!} = \frac{5 \times 4 \times 3 \times 2 \times 1}{3 \times 2 \times 1 \times 2 \times 1} = 5 \times 2 = 10, \text{ so } z = 10.$$

Therefore, the value of  $yz$  is  $(5)(10) = 50$ . The correct answer is E.

### 59.

We are given an equation with two variables and asked to find the product of the variables. At first glance, it may look impossible to solve this equation for  $x$  and  $y$ , since we have two variables and only one equation. On top of that, the variables appear only as exponents. And, to pile it on, each answer choice has so many factors that it would be totally impractical to start by plugging in numbers. However, using a combination of algebra and logic, we can figure out the values of  $x$  and  $y$  and then find their product.

First, let's rewrite the given equation so that all the variables are moved to one side:

$$\begin{aligned}
5^x - 5^y &= (2^{y-1})(5^{x-1}) && \text{divide both sides by } (5^{x-1}) \\
\frac{5^x}{5^{x-1}} - \frac{5^y}{5^{x-1}} &= 2^{y-1} && \text{simplify the first term} \\
5 - \frac{5^y}{5^{x-1}} &= 2^{y-1} && \text{add } \frac{5^y}{5^{x-1}} \text{ to both sides} \\
5 &= 2^{y-1} + \frac{5^y}{5^{x-1}}
\end{aligned}$$

Now, some logic is necessary to finish up.

We know that that both terms,  $2^{y-1}$  and  $\frac{5^y}{5^{x-1}}$ , are positive.

Since  $2^{y-1} + \frac{5^y}{5^{x-1}}$  must equal 5, we also know that  $2^{y-1}$  and  $\frac{5^y}{5^{x-1}}$  must each be less than 5.

We can now list all the possibilities, by testing small integer values for  $y$ . We only have to test a few values because we know that  $2^{y-1}$  must be less than 5, which means that  $y$  can only be 1, 2 or 3. (If  $y$  is 4, then  $2^{y-1}$  would be 8, which is greater than 5.)

If  $y = 1$ , then  $2^{y-1} = 2^{1-1} = 2^0 = 1$ , which means that  $\frac{5^y}{5^{x-1}}$  must equal 4 (remember, the sum of the two terms must be equal to 5). However, since  $x$  and  $y$  are positive integers, there is no way to make  $\frac{5^y}{5^{x-1}}$  equal to 4.

If  $y = 2$ , then  $2^{y-1} = 2^{2-1} = 2$ , which means that  $\frac{5^y}{5^{x-1}}$  must equal 3. However, since  $x$  and  $y$  are positive integers, there is no way to make  $\frac{5^y}{5^{x-1}}$  equal to 3.

If  $y = 3$ , then  $2^{y-1} = 2^{3-1} = 2^2 = 4$ , which means that  $\frac{5^y}{5^{x-1}}$  must equal 1. This is possible. Using  $y = 3$ , we can solve for  $x$  as follows:

$$\frac{5^y}{5^{x-1}} = 1 \quad \rightarrow \quad \frac{5^3}{5^{x-1}} = 1 \quad \rightarrow \quad 5^3 = 5^{x-1} \quad \rightarrow \quad 3 = x - 1 \quad \rightarrow \quad x = 4$$

The only possible solution is  $y = 3$  and  $x = 4$ . Therefore,  $xy = (4)(3) = 12$ . The correct answer is E.

60.

$$\frac{5^a 2^b 3^c}{5^d 2^e 3^f} = 3$$

From the problem statement, we know that  $\frac{5^a 2^b 3^c}{5^d 2^e 3^f} = 3$ . We also know that the digits  $b$ ,  $c$ ,  $e$ , and  $f$  are integers from 0 to 9 and that the digits  $a$  and  $d$  are integers from 1 to 9 (they cannot be 0 since they are in the hundreds place).

For the statement above to be true,  $5^a 2^b$  must equal  $5^d 2^e$ , and  $\frac{3^c}{3^f} = 3^1$ . Therefore,  $a = d$ ,  $b = e$ , and  $c - f = 1$ .

Since the only difference between  $abc$  and  $def$  is in the units digits, the difference between these three-digit numbers is equal to  $c - f$ , or 1.

The correct answer is A.

61.

In this type of problem, the easiest thing to do is to express both sides of the equation in terms of prime numbers. The left side of the equation is already expressed in terms of prime numbers, so we need to start by rewriting the right side of the equation in terms of prime numbers:

$$0.00064 = 64 \times 10^{-5} = 2^6 \cdot (2 \cdot 5)^{-5} = 2^6 \cdot 2^{-5} \cdot 5^{-5} = 2^1 \cdot 5^{-5}$$

Thus, the given equation can be rewritten as follows:

$$2^x 5^y z = 2^1 5^{-5}$$

Quite a bit is revealed by putting the equation in this form. The right side of the equation, which we will call the "target", is comprised only of 2's and 5's. Looking at the left side of the equation, we see that we have  $x$  number of 2's and  $y$  number of 5's along with some factor  $z$ . This unknown factor  $z$  must be comprised of only 2's, only 5's, some combination of 2's and 5's, or it must be 1 (i.e. with no prime factors). This is because any other prime components of  $z$  would yield a product that is different from the target.

The question asks us to solve for  $xy$ , which we can certainly do by determining the values of both  $x$  and  $y$ . Since  $x$  and  $y$  simply tell us the number of 2's and 5's, respectively, that will be contributed toward the product on the left side of the equation (e.g., if  $x = 2$  and  $y = 3$ , there are two 2's and three 5's toward the product), we can look at this question in a slightly different light. The only other contributor to the final product on the left side is  $z$ . If we knew how many 2's and/or 5's that  $z$  contributed to the product, this would be enough to tell us what  $x$  and  $y$  are. After the inclusion of  $z$ , any surplus or deficit of 2's would have to be covered by  $x$  and any surplus or deficit of 5's would have to be covered by  $y$ . In other words, the question what is  $xy$  can be rephrased as what is  $z$ ?

In statement (1) we are told that  $z = 20$ , which is sufficient to answer our rephrased question. Just to illustrate, this statement means that  $z$  provides the product  $2^x 5^y$  on the left side of our

equation with two additional 2's and an additional 5, since  $20 = 2^2 \cdot 5$ . We can use this information to solve for  $x$  and  $y$  as follows:

$$2^x 5^y z = 2^{15} 5^{-5}$$

$$2^x 5^y 2^2 5 = 2^{15} 5^{-5}$$

$$2^x 5^y = \frac{2^{15} 5^{-5}}{2^2 5}$$

$$2^x 5^y = 2^{-15} 5^{-6}$$

In statement (2) we are given the number of 2's contributed by the expression  $2^x$  on the left side of the equation. To hit the target,  $z$  must contain exactly two 2's, since  $2^{-1} \cdot 2^2 = 2^1$ . But what about 5's? Is the expression  $5^y$  the only source of 5's or is  $z$  composed of 5's as well? We have no way of knowing so we cannot find the value of  $z$  (or  $y$ ).

The correct answer is (A): Statement (1) alone is sufficient, but statement (2) alone is not sufficient.

## 62.

One of the most effective ways to begin solving problems involving exponential equations is to break down bases of the exponents into prime factors and combine exponents with the same base. Following this approach, be sure to simplify each statement as much as possible before arriving at the conclusion, since difficult problems with exponents often result in unobvious outcomes.

(1) INSUFFICIENT: While this statement gives us the value of  $x$ , we know nothing about  $y$  and cannot determine the value of  $x^y$ .

(2) SUFFICIENT:

$$(128^x)(6^{x+y}) = (48^{2x})(3^{-x})$$

$$(2^7)^x (2 \times 3)^{x+y} = (2^4 \times 3)^{2x} (3^{-x})$$

$$(2^{7x})(2^{x+y})(3^{x+y}) = (2^{8x})(3)^{2x}(3^{-x})$$

$$(2^{8x+y})(3^{x+y}) = (2^{8x})(3)^{2x-x}$$

$$(2^8)^x (2^y)(3^x)(3^y) = (2^8)^x (3)^x$$

$$(2^y)(3^y) = 1$$

$$(2 \times 3)^y = 1$$

$$6^y = 1$$

$$y = 0$$

Since  $y = 0$  and  $x$  is not equal to zero (as stated in the problem stem), this information is sufficient to conclude that  $x^y = x^0 = 1$ .

The correct answer is B.

## 63.

In order to evaluate the function  $f(n)$ , simply substitute the value of  $n$  for every instance of  $n$  on the right-hand-side of the definition of the function. For example, for  $n = 4$ ,  $f(4) = f(3) - 4$ . Note that the value of  $f(n)$  is dependent on the value of  $f(n - 1)$ . Therefore, in order to find  $f(4)$ , we must know  $f(3)$ . So one way of rephrasing the question is: "What is the value of  $f(3)$ ?"

However, let's suppose we don't know  $f(3)$  but we know  $f(2)$ . Since,  $f(3) = f(2) - 3$ , we can calculate the value of  $f(3)$  from  $f(2)$ , then  $f(4)$  from  $f(3)$ . Continuing this logic, if we know the value of  $f(1)$ , we can calculate the value of  $f(2)$  from  $f(1)$ , then  $f(3)$  from  $f(2)$ , and then  $f(4)$  from  $f(3)$ . It is apparent that if we know the value for  $f(i)$  where  $i$  is any integer less than 4, we can eventually get to the value of  $f(4)$  by successive calculating  $f(n)$  for increasing  $n$ 's.

We can also rearrange the equation  $f(n) = f(n - 1) - n$  to  $f(n - 1) = f(n) + n$ . So if we know  $f(5)$ , then  $f(5 - 1)$  or  $f(4) = f(5) + 5$ . Hence, given  $f(5)$ , we can calculate  $f(4)$ . Using similar logic as above, if we know  $f(6)$ , we can calculate the value of  $f(5)$  from  $f(6)$ , then  $f(4)$  from  $f(5)$ . We can see that we know the value of  $f(i)$  for any integer  $i$  greater than 4, we can eventually get to the value of  $f(4)$  by successively calculating  $f(n - 1)$  for decreasing  $n$ 's.

Therefore, if we know the value of  $f(i)$  for any one specific value of  $i$ , we can get to the value of  $f(4)$ ; hence, the question can be restated as: **“What is the value of  $f(i)$  for any specific integer  $i$ ?”**

(1) SUFFICIENT. Since we are given the value of  $f(i)$  for the specific integer  $i = 3$ , it follows that  $f(4)$  can be calculated.

(2) SUFFICIENT. Since we are given the value of  $f(i)$  for the specific integer  $i = 6$ , it follows that  $f(4)$  can be calculated.

The correct answer is D.

64.

Since we know the value of  $\#-7\# = 3$ , we can plug  $p = -7$  into our formula:

$$\begin{aligned} (-7)^3a + (-7)b - 1 &= 3 \\ -343a - 7b &= 3 \\ -343a - 7b &= 4 \end{aligned}$$

We are asked to solve for  $\#7\#$ . If we plug 7 into our formula, we get:

$$\begin{aligned} (7)^3a + (7)b - 1 &= ? \\ 343a + (7)b - 1 &= ? \end{aligned}$$

To figure this out, we would need to know the value of  $343a + 7b$ .

From the first equation we know that  $-343a - 7b = 4$ . By multiplying both sides by negative one, we see that  $343a + 7b = -4$ .

$$343a + 7b - 1 = ?$$

$$-4 - 1 = -5$$

The correct answer is E.

65.

It helps to recognize that this is a quadratic equation problem presented as a function problem. What we are essentially being told is that 6 and -3 are the two zeros for the equation  $x^2 + bx + c$ . In other words, 6 and -3 are the two solutions to the equation  $x^2 + bx + c = 0$ . Because solutions are always the opposites of the factor numbers, we know that our equation in factored form is

$$(x - 6)(x + 3) = 0$$

which, when FOILed, becomes

$$x^2 - 3x - 18 = 0$$

So  $b = -3$ , and  $c = -18$ . Therefore,  $b + c = -21$ .

Alternatively, we can find the values of  $b$  and  $c$  by using substitution.

$$\text{If } f(6) = 0, \text{ then}$$

$$6^2 + b(6) + c = 0$$

$$6b + c = -36$$

$$\text{If } f(-3) = 0, \text{ then}$$

$$(-3)^2 + b(-3) + c = 0$$

$$-3b + c = -9$$

We can combine the two equations and solve. In this method, we add or subtract the two equations to eliminate one of the variables. In this problem, we can use subtraction to eliminate  $c$ .

$$\begin{array}{r} 6b + c = -36 \\ - (-3b + c = -9) \\ \hline 9b = -27 \\ b = -3 \end{array}$$

We can substitute -3 for  $b$  into either of the above equations to get  $c = -18$ . It follows that  $b + c = -21$ .

The correct answer is D.

66.

This problem can be solved algebraically or by plugging in the answer choices; both methods are shown below.

### *Algebra*

Because there are square root signs on both sides of the equation, we can square both sides to get rid of them, which leaves us with  $4 + x^{1/2} = x + 2$ .  $x^{1/2}$  is the same thing as  $\sqrt{x}$ , so our next step is to isolate the radical sign and then square both sides again. Once we do this, we can solve for  $x$ .

$$\begin{aligned}\sqrt{x} &= x - 2 \\ x &= (x - 2)^2 \\ x &= x^2 - 4x + 4 \\ 0 &= x^2 - 5x + 4 \\ 0 &= (x - 4)(x - 1)\end{aligned}$$

$x$  can equal either 4 or 1; try each to determine which one is the solution to the original equation:

$$x = 4: \sqrt{4 + 4^{1/2}} = \sqrt{4 + 2} = \sqrt{6}, \text{ so } x \text{ can equal } 4.$$

$$x = 1: \sqrt{4 + 1^{1/2}} \neq \sqrt{1 + 2}, \text{ so } x \text{ cannot equal } 1.$$

Only  $x = 4$  works.

### *Plugging in the answers*

Since the numerical answers represent a possible value for  $x$ , we can also plug them into the equation and see which one works. Remember that we can stop when we find the right answer and it's also best to start with answer choice C. If C does not work, we can sometimes determine whether we want to try a larger or smaller number next, thereby saving some time.

$$(A) \sqrt{4 + (-1)^{1/2}} = \sqrt{(-1) + 2} \quad \text{FALSE}$$

$$(B) \sqrt{4 + (0)^{1/2}} = \sqrt{0 + 2} \quad \text{FALSE}$$

$$(C) \sqrt{4 + (1)^{1/2}} = \sqrt{1 + 2} \quad \text{FALSE}$$

$$(D) \sqrt{4 + (4)^{1/2}} = \sqrt{4 + 2} \quad \text{TRUE}$$

(E) Since D works, the answer can be determined. FALSE

The correct answer is D.

67.

The equation in question can be rephrased as follows:

$$\begin{aligned}x^2y - 6xy + 9y &= 0 \\ y(x^2 - 6x + 9) &= 0\end{aligned}$$

$$y(x - 3)^2 = 0$$

Therefore, one or both of the following must be true:

$$y = 0 \text{ or}$$

$$x = 3$$

It follows that the product  $xy$  must equal either 0 or  $3y$ . This question can therefore be rephrased "What is  $y$ ?"

(1) INSUFFICIENT: This equation cannot be manipulated or combined with the original equation to solve directly for  $x$  or  $y$ . Instead, plug the two possible scenarios from the original equation into the equation from this statement:

If  $x = 3$ , then  $y = 3 + x = 3 + 3 = 6$ , so  $xy = (3)(6) = 18$ .

If  $y = 0$ , then  $x = y - 3 = 0 - 3 = -3$ , so  $xy = (-3)(0) = 0$ .

Since there are two possible answers, this statement is not sufficient.

(2) SUFFICIENT: If  $x^3 < 0$ , then  $x < 0$ . Therefore,  $x$  cannot equal 3, and it follows that  $y = 0$ . Therefore,  $xy = 0$ .

The correct answer is B.